	ENVIRONMENTAL LICENSE MODIFICATION FOR THE CONSTRUCTION AND OPERATION PROJECT OF A PORT TERMINAL OF SOLID BULK CARGOES IN THE MUNICIPALITY OF TURBO	
	PROJECT DESCRIPTION	Page 1 of 165
	GAT-391-15-CA-AM-PIO-01	Revision: <input type="text"/>

PROJECT DESCRIPTION

B	16/10/2015	Project description	Carlos Rey Julio Mesa	Carlos Rey	Carlos Rey
B	26/10/2015	Project description	Carlos Rey Sebastián Piedrahíta	Carlos Rey	Carlos Rey
			[Signature]	[Signature]	[Signature]
REVISION	DESCRIPTION		MADE BY	REVISED BY	APPROVED BY

Revision A: Issued for Customer Comments

Revision B: Issued for Customer Approval

Revision 0: Approved for Basic Engineering





	ENVIRONMENTAL LICENSE MODIFICATION FOR THE CONSTRUCTION AND OPERATION PROJECT OF A PORT TERMINAL OF SOLID BULK CARGOES IN THE MUNICIPALITY OF TURBO	
	PROJECT DESCRIPTION	Page 2 of 165
	GAT-391-15-CA-AM-PIO-01	Revision:

TABLE OF CONTENTS

	Page
3 PROYECT DESCRIPTION.....	8
3.1 Location.....	8
3.2 Project features	10
3.2.1 Existing conditions	10
3.2.2 Projects phases and activities	16
3.2.2.1 Phase 1	16
3.2.2.2 Phase 2.....	18
3.2.3 Project design	21
3.2.3.1 Layout and geometric characteristics of the works to be built subject of the project.....	22
3.2.3.2 Constructive process.....	40
3.2.4 Port facilities	60
3.2.4.1 Description of Onshore Terminal Facilities.....	60
3.2.4.2 Infrastructure associated with the project.....	71
3.2.4.3 Infrastructure and services intercepted by the project.....	76
3.2.5 Project inputs	76
3.2.5.1 Volumes of Building Materials	76
3.2.5.2 Leftover materials.....	77
3.2.6 Operation phase	77
3.2.6.1 Port Operations Description	78
3.2.6.2 Machinery.....	95
3.3 Handling and disposal of leftover materials from excavation and debris ..	98
3.3.1 Handling and disposal of dredged materials	99
3.3.2 Modeling of dredging and dispersion of sediments.....	99
3.3.2.1 Scattering Halo.....	120

	ENVIRONMENTAL LICENSE MODIFICATION FOR THE CONSTRUCTION AND OPERATION PROJECT OF A PORT TERMINAL OF SOLID BULK CARGOES IN THE MUNICIPALITY OF TURBO	
	PROJECT DESCRIPTION	Page 3 of 165
	GAT-391-15-CA-AM-PIO-01	Revision:

3.3.3 Modeling of heavy metal unloadings according to the type of dredging 137

3.3.3.1	Quality of deep sea sediments	137
3.3.3.2	Results obtained from depth sediment sampling.....	139
3.3.3.3	Analysis and comparison with the regulations.....	142
3.4	Hazardous and non-hazardous waste.....	153
3.5	Project costs.....	155
3.6	Project schedule.....	156
3.7	Project organization.....	160

FIGURES LIST

	Page
Figure Num. 3.1 Project localization.....	9
Figure Num. 3.2. Photographs of existing infrastructure. a) Warehouse, b) Kiosk, c) road and d) dock.....	11
Figure Num. 3.3. Protective Forest Reserve (Reserva forestal protectora) of the León-Suriquí Wetlands	13
Figure Num. 3.4. Collective protection route	14
Figure Num. 3.5. Presence of mining titles in the catchment area of the project	15
Figure Num. 3.6. Exploratory block registration.....	16
Figure Num. 3.7. Phases of the maritime dock.....	19
Figure Num. 3.8 Adjustment example of the Phases Geometry	20
Figure Num. 3.9. Phases and number of docks in the Offshore platform.....	24
Figure Num. 3.10. Cross section of the maritime dock.....	25
Figure Num. 3.11. Splice platform.....	26
Figure Num. 3.12. Section of the viaduct	28
Figure Num. 3.13. Bridge over The León Riiver	29



	ENVIRONMENTAL LICENSE MODIFICATION FOR THE CONSTRUCTION AND OPERATION PROJECT OF A PORT TERMINAL OF SOLID BULK CARGOES IN THE MUNICIPALITY OF TURBO	
	PROJECT DESCRIPTION	Page 4 of 165
	GAT-391-15-CA-AM-PIO-01	Revision:

Figure Num. 3.14. Dock on the north shore of the artificial Channel of Nueva Colonia.....	30
Figure Num. 3.15. Onshore Terminal.....	31
Figure Num. 3.16. Dredging areas.....	32
Figure Num. 3.17. Geotechnical drilling and stratigraphic profile.....	35
Figure Num. 3.18. Location of the dump.....	36
Figure Num. 3.19. The method of unloading dredged material in dump.....	38
Figure Num. 3.20. Stabilization by gravel columns.....	44
Figure Num. 3.21. Stabilization by vibrocompaction.....	45
Figure Num. 3.22. Stabilization with jet-grouting.....	46
Figure Num. 3.23. Anchorage of barges and location and transport of piles.....	47
Figure Num. 3.24. Maritime dock and viaduct construction process.....	50
Figure Num. 3.25. DELMAG hammer and crane.....	54
Figure Num. 3.26. Reinforcement installation inside the pile.....	55
Figure Num. 3.27. Formwork elevation for cast.....	56
Figure Num. 3.28. Longitudinal elevation support structure and arc starting.....	57
Figure Num. 3.29. Longitudinal elevation assembly of elements that make up the arch...	58
Figure Num. 3.30. Longitudinal elevation assembly of kingposts and lower board.....	59
Figure Num. 3.31. Silos and grain storage warehouses Puerto Bahía Colombia de Urabá.....	65
Figure Num. 3.32. Liquid bulk silos.....	66
Figure Num. 3.33. Location of valves for sectorization of the fire network, red arrow with blue.....	69
Figure Num. 3.34. Typical section of road structure from Nueva Colonia to Puerto Bahía Colombia de Urabá.....	75
Figure Num. 3.35. Typical section of box culvert Puerto Bahía Colombia de Urabá.....	76



	ENVIRONMENTAL LICENSE MODIFICATION FOR THE CONSTRUCTION AND OPERATION PROJECT OF A PORT TERMINAL OF SOLID BULK CARGOES IN THE MUNICIPALITY OF TURBO	
	PROJECT DESCRIPTION	Page 5 of 165
	GAT-391-15-CA-AM-PIO-01	Revision:

Figure Num. 3.36. Flowchart of operation of containers.	82
Figure Num. 3.37. Specialized vehicles for bulk transport, high speed unloading hopper and coupled tandem.	85
Figure Num. 3.38. Solid bulk operation Flow Chart.	86
Figure Num. 3.39. Laiding type discharge system.....	88
Figure Num. 3.40. Flow diagram of general cargo operation.....	89
Figure Num. 3.41. Flow chart of Ro-Ro operation.	91
Figure Num. 3.42. Liquid bulk operation flux chart.	94
Figure Num. 3.43. Location of dump and dispersion limit.	99
Figure Num. 3.44. Nautical chart 625.....	101
Figure Num. 3.45. Detail bathymetry of the dump area.	101
Figure Num. 3.46. Bathymetry of the Golfo de Urabá.....	102
Figure Num. 3.47. Evaluation of the dredging trajectory for the suction dredge.....	104
Figure Num. 3.48. Trajectory material dumping in the dump	105
Figure Num. 3.49. Operation diagram of the IH-Dredge methodology (modified by Aqua & Terra Consultores S.A.S) for the simulation of a real-time dredging process with a suction dredger.	106
Figure Num. 3.50. Location of the point where the harmonic components of the TPXO were obtained	114
Figure Num. 3.51. Series of astronomical tide for the point to the outskirts of the Golfo de Urabá. a) Series for the first semester of the year and b) series for the second semester of the year.....	115
Figure Num. 3.52. Annual Wind season of Turbo station.	118
Figure Num. 3.53. Location of REDCAM stations	121
Figure Num. 3.54. Concentration of suspended solids for a discharge cell in the dump ..	122
Figure Num. 3.55. Location of dredging area and dump	123



	ENVIRONMENTAL LICENSE MODIFICATION FOR THE CONSTRUCTION AND OPERATION PROJECT OF A PORT TERMINAL OF SOLID BULK CARGOES IN THE MUNICIPALITY OF TURBO	
	PROJECT DESCRIPTION	Page 6 of 165
	GAT-391-15-CA-AM-PIO-01	Revision:

Figure Num. 3.56. Sequence of greater dispersion on the perimeter of the dump. 130

Figure Num. 3.57. Dispersion of total suspended solids for a discharge 132

Figure Num. 3.58. SST Concentration of the first semester discharge (N 1,374,755.75 m;
E 697,097.53 m). 133

Figure Num. 3.59. Sequence of greater dispersion on the perimeter of the dump, for the
second semester of the year. 136

Figure Num. 3.60 Location of perforations 138

Figure Num. 3.61. Mercury behavior 152

Figure Num. 3.62. Temporary series of material poured into the dump. 153

Figure Num. 3.63. Proposal for the Project Organization. 160

TABLES LIST

	Page
Table Num. 3.1. Coordinates limiting the perimeter of the dock.	9
Table Num. 3.2. Coordinates limiting the perimeter of the onshore terminal.	9
Table Num. 3.3. Port facilities and areas.....	17
Table Num. 3.4. Projected cargo in the short and long term.....	21
Table Num. 3.5. Vessels designs.....	22
Table Num. 3.6. Mooring post capacity.....	22
Table Num. 3.7. Calculation of the sedimented volume between 2001 and 2012 in the anchoring zone.	33
Table Num. 3.8. Coordinates of the dump area.....	37
Table Num. 3.9. List of equipment that could be used depending on availability in the market	38





	ENVIRONMENTAL LICENSE MODIFICATION FOR THE CONSTRUCTION AND OPERATION PROJECT OF A PORT TERMINAL OF SOLID BULK CARGOES IN THE MUNICIPALITY OF TURBO	
	PROJECT DESCRIPTION	Page 7 of 165
	GAT-391-15-CA-AM-PIO-01	Revision:

Table Num. 3.10. Bulk storage capacity.....	63
Table Num. 3.11. Areas built onshore facilities that require hydrants	67
Table Num. 3.12. Available materials.....	73
Table Num. 3.13. Substation areas.....	74
Table Num. 3.14. Concrete volumes for onshore terminal.	76
Table Num. 3.15. Volumes of dock and viaduct materials.....	77
Table Num. 3.16. Bulk loading operation.	85
Table Num. 3.17. Solid flow introduced by León and Atrato rivers to Golfo de Urabá	113
Table Num. 3.18 Tidal harmonic components, obtained from TPXO	113
Table Num. 3.19 Selection of cases	119
Table Num. 3.20. Historical values of Total Suspended Solids in Bahía Colombia (mg/l).....	121
Table Num. 3.21. Coordinates of the perforations	137
Table Num. 3.22. Results of analysis of the physico-chemical quality of deep sea sediments	140
Table Num. 3.23. Values associated with Action Levels 1 and 2 in the Spanish standard	143
Table Num. 3.24. CEDEX category for dredged material based on the concentration of pollutants	145
Table Num. 3.25. Comparison of results in PF8 with the Spanish norm and classification of the results	145
Table Num. 3.26. Comparison of results in PF9 with the Spanish norm and classification of the result.	147
Table Num. 3.27. Comparison of results in PF10 with the Spanish norm and classification of the result.....	149

	ENVIRONMENTAL LICENSE MODIFICATION FOR THE CONSTRUCTION AND OPERATION PROJECT OF A PORT TERMINAL OF SOLID BULK CARGOES IN THE MUNICIPALITY OF TURBO	
	PROJECT DESCRIPTION	Page 8 of 165
	GAT-391-15-CA-AM-PIO-01	Revision:

3 PROYECT DESCRIPTION

3.1 Location

The project of Puerto Bahía Colombia de Urabá is located on the south side of Bahía Colombia of the Urabá Golfo, the Caribbean Sea of the Atlantic coast of Colombia, near to the León River mouth and the channel of Nueva Colonia town, belonging to the municipality of Turbo, Antioquia.

The project is located 2600 m upstream from the León River mouth, at coordinates 7 ° 55'28 " North latitude and 76 ° 44'15 " West longitude. The average height of the project is 1.5 masl According to its location, the project is adjacent to:



North: Colombia Bay, Urabá Golfo and the Municipality of Turbo

South: Channel of Nueva Colonia, Municipality of Apartadó and Carepa, department of Antioquia.

East: Jurisdiction of Turbo, Nueva Colonia and Río Grande.

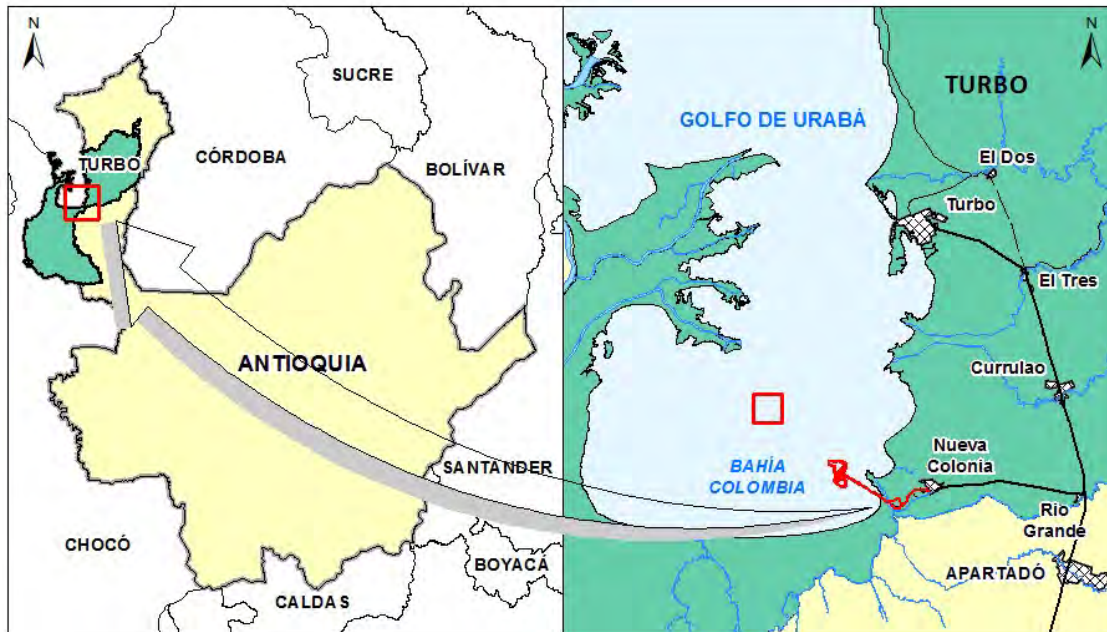
West: The León River and Border with Panama.



	ENVIRONMENTAL LICENSE MODIFICATION FOR THE CONSTRUCTION AND OPERATION PROJECT OF A PORT TERMINAL OF SOLID BULK CARGOES IN THE MUNICIPALITY OF TURBO	
	PROJECT DESCRIPTION	Page 9 of 165
	GAT-391-15-CA-AM-PIO-01	Revision:

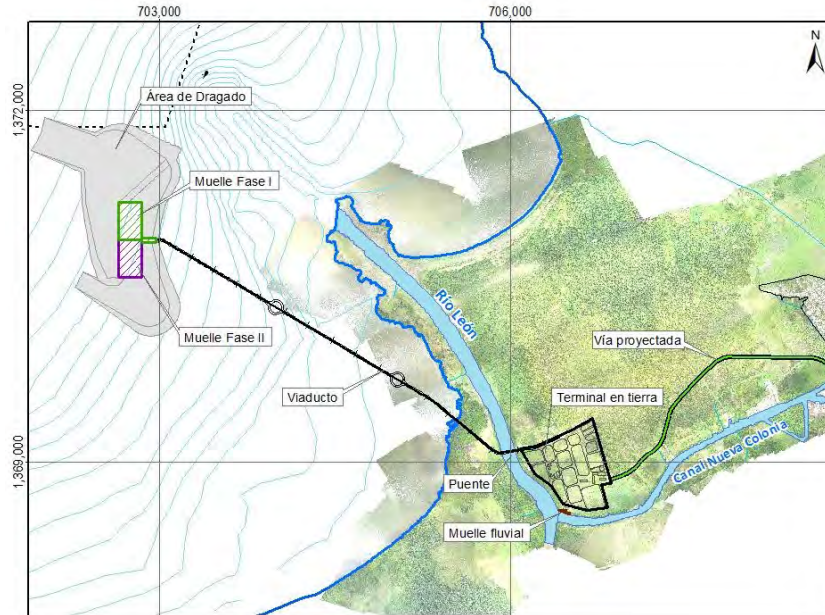

Figure Num. 3.1 Project localization.
Source: Aqua & Terra Consultores Asociados.

The project is located in two relevant sectors and named as onshore terminal and dock. The connection between the two sectors is developed from a viaduct. The coordinates of each of the sectors are:

Table Num. 3.1. Coordinates limiting the perimeter of the dock.



Point	North	East
1	1371214.45	702645.89
2	1371214.45	702845.89
3	1370574.93	702845.89
4	1370574.93	702645.89

Source: Aqua & Terra Consultores SAS.

The onshore terminal is located 50 meters east of the right bank of The León River.

Table Num. 3.2. Coordinates limiting the perimeter of the onshore terminal.

Point	North	East
1	1369113.603	706081.135
2	1369270.235	706.6519.645
3	1369371.024	706698.387
4	1368815.985	706857.085

	ENVIRONMENTAL LICENSE MODIFICATION FOR THE CONSTRUCTION AND OPERATION PROJECT OF A PORT TERMINAL OF SOLID BULK CARGOES IN THE MUNICIPALITY OF TURBO	
	PROJECT DESCRIPTION	Page 10 of 165
	GAT-391-15-CA-AM-PIO-01	Revision:

Point	North	East
5	1368807.805	706770.907
6	1368607.500	706825.340
7	1368589.745	706647.135
8	1368637.195	706441.995
9	1368800.797	706338.436
10	1368900.580	706201.710

Source: Aqua & Terra Consultores SAS.

The connection between the onshore terminal and the dock will be made through a viaduct that will cross The León River with a bridge of free length between piles of 137.91 m and a total length of the viaduct of 4200 m (including the bridge and splice platform). The project area of the onshore terminal consists of 35 hectares (ha) and the maritime dock of 12.8 ha.

3.2 Project features

In this chapter there will be a brief description of the characteristics of the project, which will relate the existing conditions, phases and construction processes, design, supplies, material handling, costs and organization of the Puerto Bahía Colombia de Urabá project.



The main purpose of this port facility is a multipurpose one, focused mainly on the following sectors:

- Exportation of perishable foods such as bananas, plantains and exotic fruits.
- Exportation and Importation of containers.
- Importation of motor vehicles.
- Importation and Exportation of bulks, both solid and liquid.

3.2.1 Existing conditions

The existing infrastructure in the project area is listed below:

- Storage warehouse with an approximate area of 1400 m².
- Surveillance kiosk.
- Road in road-bed of 870 m in length and 4 m in width.
- Dock.

	ENVIRONMENTAL LICENSE MODIFICATION FOR THE CONSTRUCTION AND OPERATION PROJECT OF A PORT TERMINAL OF SOLID BULK CARGOES IN THE MUNICIPALITY OF TURBO	
	PROJECT DESCRIPTION	Page 11 of 165
	GAT-391-15-CA-AM-PIO-01	Revision:



a) Warehouse



b) Kiosk



c) Road





d) Dock

Figure Num. 3.2. Photographs of existing infrastructure. a) Warehouse, b) Kiosk, c) road and d) dock.

Source: Aqua & Terra Consultores SAS.

The existing road is classified as a third order road, according to the criteria established by the Ministry of Transport, defined below:

- Network of Third Order Simple Roadway \leq to 6.00 m
- Third Order Network $> = 1$ Veh / day < 150 Veh / day
- Third Order Network Allows communication at the village level
- Network of Third Order Municipal seats with less than 15,000 inhabitants

	ENVIRONMENTAL LICENSE MODIFICATION FOR THE CONSTRUCTION AND OPERATION PROJECT OF A PORT TERMINAL OF SOLID BULK CARGOES IN THE MUNICIPALITY OF TURBO	
	PROJECT DESCRIPTION	Page 12 of 165
	GAT-391-15-CA-AM-PIO-01	Revision:

Accordingly to the infrastructure related to the points contemplated in article 7 of law 1682 of November 22, 2013, the following sections are considered:

- a) The urban, architectural, cultural and archaeological heritage;

Accordingly to the information reported in the characterization of the project, in the area of influence no movable and immovable property that is cataloged as cultural, architectural heritage is reported.

Accordingly to the information regarding the archaeological potential of the area, the environmental impact study, volumes I, II and III. *"CONSTRUCCIÓN Y OPERACIÓN DE UN TERMINAL PORTUARIO DE GRANELES SÓLIDOS"* indicates that an archaeological study is not justified since *"DIMAR does not consider Bahía Colombia of interest for shipwrecked species and even less the mouths of The León Riiver, recognizing that this zone in particular was not the subject of the entry of galleons during the periods of the conquest"* (Araújo Ibarra & Asociados SA Page 37).



On the other hand they conclude that; *"The land area of the project corresponds to a recently emerged area, derived from the sedimentation processes caused by the heavy load of sediments of The León Riiver and the disposal of dredged material from The León Riiver and the Nueva Colonia channel. For this reason, on these swampy soils or with prolonged flooding (according to the classification of soils of the IGAC), and given the intensity of the floods in the area, it is not possible to find archaeological vestiges of pre-Hispanic communities in the area of interest"*

However, on August 24th, 2015, the formulation of the Archaeological Management Plan for the evaluation of said entity was established at the Instituto Colombiano de Antropología e Historia (ICANH) (see Annex 5.3.7.2).

- b) The resources, goods or areas subject to authorization, permit or environmental license or in process of declaration of reservation, exclusion or protected areas.

The Reserva Forestal Protectora (Protective Forest Reserve) of León-Suriquí Wetlands of the municipality of Turbo is registered, which was object of partial subtraction through the Agreement 100-02-02-01-0004-2011 of March of 2011 by means of which *"it is partially and temporarily subtracted an area of the reserve and partially uplifts a ban"*.

With respect to the previous subtraction, the Sociedad Portuaria Puerto Bahía Colombia S.A, through file 200-34-58-3237, requested clarification of the aforementioned agreement (agreement 100-02-02-01-011-2009) to rectify the coordinates of the subtracted area.

	ENVIRONMENTAL LICENSE MODIFICATION FOR THE CONSTRUCTION AND OPERATION PROJECT OF A PORT TERMINAL OF SOLID BULK CARGOES IN THE MUNICIPALITY OF TURBO	
	PROJECT DESCRIPTION	Page 14 of 165
	GAT-391-15-CA-AM-PIO-01	Revision:

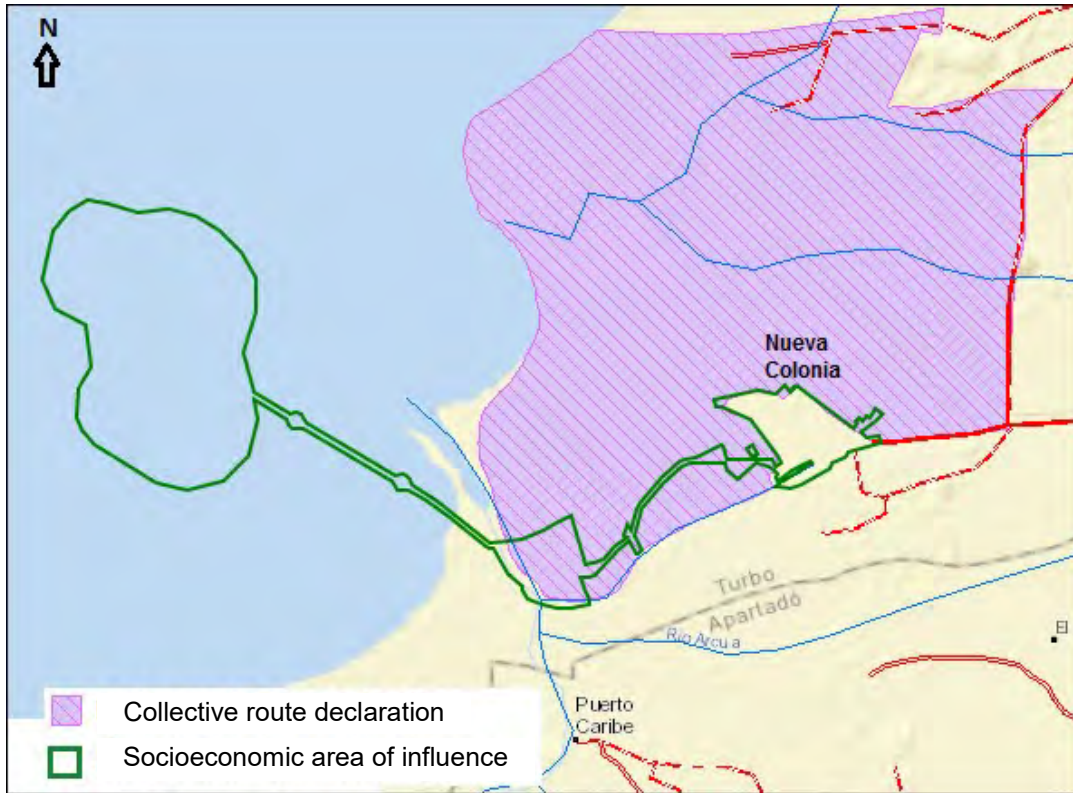

Figure Num. 3.4. Collective protection route

Pink: Collective route declaration

Green: Socioeconomic area of influence



Source: Geovisor _National Licensing of Environmental Licenses -ANLA.

d) The established ethnic communities.

In the Area of Influence of the project, the presence of ethnic communities is not registered, in accordance with Certification No. 1099 of August 4, 2015, issued by the Ministry of the Interior through the Office of Prior Consultation (Previous Consultation Address).

e) Mining titles in award processes, granted, existing and in operation;

Based on the information reported in the mining cadastre, no concessions or mining titles are reported in the study area, as shown in the following figure:

	ENVIRONMENTAL LICENSE MODIFICATION FOR THE CONSTRUCTION AND OPERATION PROJECT OF A PORT TERMINAL OF SOLID BULK CARGOES IN THE MUNICIPALITY OF TURBO	
	PROJECT DESCRIPTION	Page 15 of 165
	GAT-391-15-CA-AM-PIO-01	Revision:

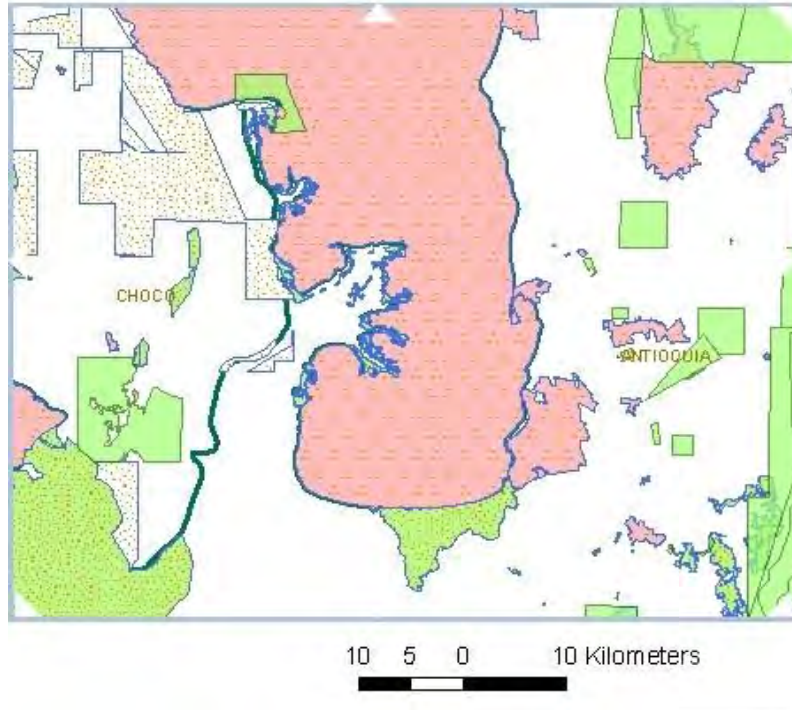



Figure Num. 3.5. Presence of mining titles in the catchment area of the project

Source: Catastro minero colombiano, 2014

In the same way, according to the information reported in the Geovisor of the National Hydrocarbons Agency, no blocks for the exploration and exploitation of hydrocarbons are reported in the catchment area, as shown in the Figure Num. 3.6.

	ENVIRONMENTAL LICENSE MODIFICATION FOR THE CONSTRUCTION AND OPERATION PROJECT OF A PORT TERMINAL OF SOLID BULK CARGOES IN THE MUNICIPALITY OF TURBO	
	PROJECT DESCRIPTION	Page 16 of 165
	GAT-391-15-CA-AM-PIO-01	Revision:

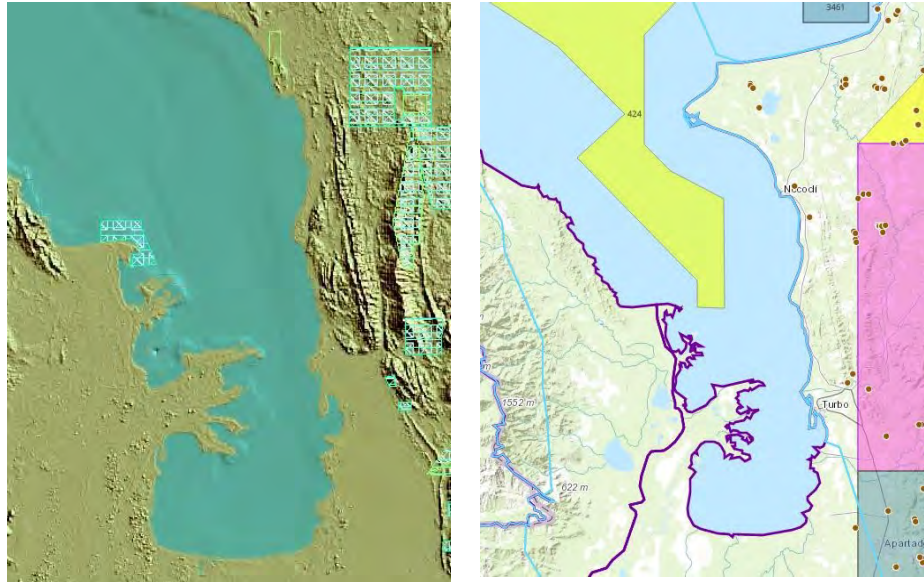

Figure Num. 3.6. Exploratory block registration

Source: Geovisor of the National Agency of Hydrocarbons ANH

Currently, the land where the project is located has port use in accordance with the Turbo POT (Agreement 022 of 2012). This area does not have utility service networks such as electricity, aqueduct and sewage.

3.2.2 Projects phases and activities

The Puerto Bahía Colombia de Urabá project is divided into 2 construction phases, described below:

3.2.2.1 Phase 1

This phase contemplates the terminal on land, bridge over the León River, connection viaduct and phase 1 of the dock. The docks phase 1, consists of 340 m long and 200 m wide, for 5 dock positions (see Figure Num. 3.9).

In this phase, the docking configuration is: western side for the container ship with 3 post-panamax gantry cranes, general cargo and solid bulk ships are distributed on the north, south and east sides. In this first phase of the dock there will be a distribution of storage areas for dry containers with a capacity of 4168 TEUs and refrigerated with a capacity of 864 TEUs, for a total capacity of 4896 TEUs in the dock phase I. (see Figure Num. 3.9)

This dock will have an operation team consisting of:

	ENVIRONMENTAL LICENSE MODIFICATION FOR THE CONSTRUCTION AND OPERATION PROJECT OF A PORT TERMINAL OF SOLID BULK CARGOES IN THE MUNICIPALITY OF TURBO	
	PROJECT DESCRIPTION	Page 17 of 165
	GAT-391-15-CA-AM-PIO-01	Revision:



- 9 RTG cranes (Rubber tyred gantry crane) Hybrid 6 + 1 x 6 + 1.
- 1 mobile crane Liebherr LHM 550
- 2 reach stacker
- 1 lift truck 10 T
- 6 hoppers
- 6 buckets

In addition to the above, this dock will have an electrical substation and generating area, a scale and a building with dining rooms and bathrooms.

On the other hand, the onshore terminal has a distribution of areas of around 41 facilities, described in the following table. (Figure Num. 3.15)

Table Num. 3.3. Port facilities and areas.

ITEM	DESCRIPTION
1	Entrance portal
2	Surveillance and control building
3	Administrative building
4	Typical dining room module (5 modules)
5	Parking for visitors
6	Parking for turn wait "enturnamiento"
7	Police narcotics housing area (improved ground) - total lot-
8	Export inspection warehouse
9	Office of anti-narcotics police
10	Bathroom module (7 modules)
11	Consolidation warehouse for the export of perishables
11A	Consolidation warehouse for individual boxes in bulk for export of perishables
11B	Area of future growth of perishable export consolidation warehouse
12	Import inspection warehouse
12A	Area of future growth of import warehouse
13	Consolidation and deconsolidation warehouse
13A	Area of future growth of consolidation and deconsolidation warehouse
14	Dockyard workshop for container washing (improved ground)
15	Dockyard workshop for containers repair (improved ground)
16	Dockyard workshop for container maintenance (improved ground)
17	Empty container yard, static capacity: 1200 TEUS (improved ground)
18	Empty container yard, static capacity: 1320 TEUS (improved ground)



	ENVIRONMENTAL LICENSE MODIFICATION FOR THE CONSTRUCTION AND OPERATION PROJECT OF A PORT TERMINAL OF SOLID BULK CARGOES IN THE MUNICIPALITY OF TURBO	
	PROJECT DESCRIPTION	Page 18 of 165
	GAT-391-15-CA-AM-PIO-01	Revision:

ITEM	DESCRIPTION
19	Empty container yard, static capacity: 2304 TEUS (improved ground)
20	Parking of trucks from farms (improved ground)
21	Parking of visitors to the accommodation of anti-narcotics police officers (improved ground)
22	Imported vehicles yard (improved ground)
23	Trailer yard (improved ground)
24	Maintenance workshop
25	Replacements warehouse
26	Main electrical substation
27	Secondary electrical substation
28	Fire station
29	Nursery
30	Gas station
31	Fuel storage and office
32	Scales
33	X-ray zone
34	Garitas
40	Bulk area (reserve area without intervention)
40A	Scale in bulk area (reserve area without intervention)
40B	Loading area in bulk (reserve area without intervention)
40C	Loading area in bulk (reserve area without intervention)
50	Areas planted with trees
51	Drinking water treatment plant
52	Water storage tank
53	Rainwater collection tank
54	Liquid bulk
55	Fluvial dock for the construction stage
60	Flexible pavement road (design vehicle: Reach stacker)
61	Road on flexible pavement (design vehicle: truck C-6o T3-S3)
62	Road on flexible pavement (design vehicle: cars)
70	Other areas with improved ground and several platforms
80	Other reserve areas without intervention

Source: PIO SAS, septiembre 2015

3.2.2.2 Phase 2

The dock phase 2 is an extension of the dock phase 1, and its dimensions are: 300m long and 200m wide. Being this phase an extension of the dock phase 1, the

	ENVIRONMENTAL LICENSE MODIFICATION FOR THE CONSTRUCTION AND OPERATION PROJECT OF A PORT TERMINAL OF SOLID BULK CARGOES IN THE MUNICIPALITY OF TURBO	
	PROJECT DESCRIPTION	Page 19 of 165
	GAT-391-15-CA-AM-PIO-01	Revision:

maritime terminal will have a total length of 640m, conserving the width of 200m. Like the dock phase 1, this will be an extension of dry and refrigerated container storage areas and therefore of static capacity, total capacity and operation equipment.

Additionally, it is important to clarify that taking into account the conditions of the port market and the current needs for the reception, unloading and storage of raw materials, a geometric design was presented in two phases (see Figure Num. 3.7). The option of location and geometry of the dock proposed for phase 1, was planned to be developed in the northern section of the dock and would consist of 340m in length and 200m in width with availability for 5 dock positions. Phase 2 has an extension and geometry similar to the dock phase 1. The dimensions proposed for the dock phase 2 are 300m long and 200m wide. The entire dock or marine terminal will have a total length of 640m, and a width of 200m.

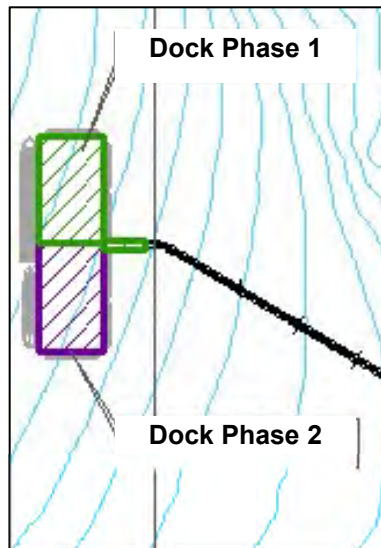



Figure Num. 3.7. Phases of the maritime dock

However, it is important to mention that the port market is dynamic and changing, as are the needs are the needs of the import and export volume of raw materials and inputs required by the country. by the country. Therefore, is considered the possibility that the geometry (but not the area of the area of the dock or marine terminal Phase 1 and Phase 2 nor its method or constructive design) constructive design) can be adjusted according to the requirements and needs. The **Red**: Example of adaption in geometry 1

	ENVIRONMENTAL LICENSE MODIFICATION FOR THE CONSTRUCTION AND OPERATION PROJECT OF A PORT TERMINAL OF SOLID BULK CARGOES IN THE MUNICIPALITY OF TURBO	
	PROJECT DESCRIPTION	Page 20 of 165
	GAT-391-15-CA-AM-PIO-01	Revision:

Green Example of adaptation in geometry 2

Figure Num. 3.8, presents an example of the possible geometries. This highlights that, regardless of the geometry, no additional areas would be intervened to those evaluated in the present study and that any adjustment in the dock geometry will be in accordance with the international construction standards and those related in the present study in terms of foundations, piles driving, concrete slabs, etc., as well as the proposed construction methods will not be modified. It is also highlighted that the area of influence will be respected, so that in dynamic conditions of the foreign market, the port solution is designed and built in terms of safety and operation that meet the highest standards of efficiency.

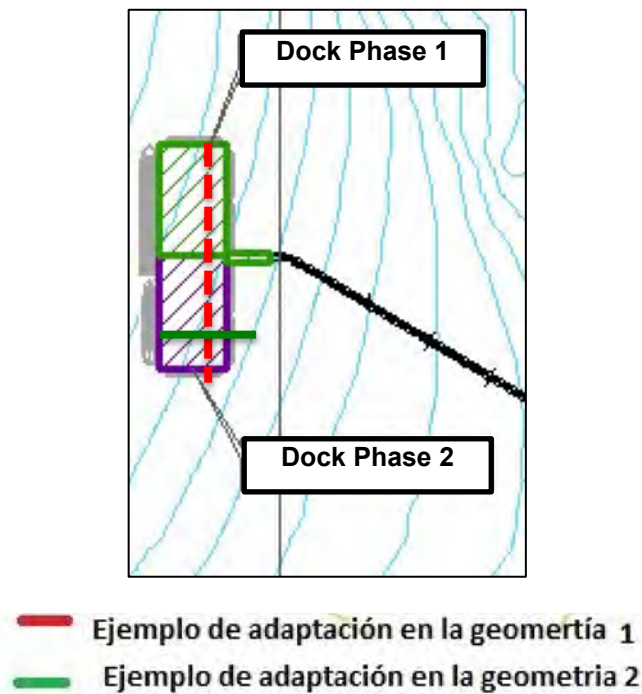



Red: Example of adaptation in geometry 1

Green Example of adaptation in geometry 2

Figure Num. 3.8 Adjustment example of the Phases Geometry

Considering the dynamics of the market and the implication of adjustments in the geometry of the project phases, it is important to mention that the evaluation of the possible environmental impacts generated by the different activities of the project, mainly in the construction stage, were evaluated contemplating the execution of

	ENVIRONMENTAL LICENSE MODIFICATION FOR THE CONSTRUCTION AND OPERATION PROJECT OF A PORT TERMINAL OF SOLID BULK CARGOES IN THE MUNICIPALITY OF TURBO	
	PROJECT DESCRIPTION	Page 21 of 165
	GAT-391-15-CA-AM-PIO-01	Revision:

these within the whole area and final geometry of the maritime dock, which allowed to know the impact and importance of the same on the identified environmental components during each stage. This allows us to conclude that an adjustment in the geometry of the phases of the dock would not generate additional impacts or an increase in the magnitude and importance of those already contemplated.

3.2.3 Project design



The Puerto Bahía Colombia de Urabá project consists of a multipurpose port for cargo handling export / import of containers, solid and liquid bulks (not hydrocarbons), vehicle import terminal. The main design features of the multipurpose port are the projection of cargo from the commercial services of the port and therefore the vessel or design vessel. The projected cargo in the short and long term (2019 and 2030, respectively), according to the load analysis, are listed below (Table Num. 3.4).

Table Num. 3.4. Projected cargo in the short and long term.

CARGA MOVILIZADA	2,018	2,019	2,020	2,021	2,022	2,023	2,024	2,025	2,026	2,027	2,028	2,029	2,030
TON Movilizada tipo de carga													
Contenedores 40 Ft. Llenos Refrig.	825,000	1,650,000	1,707,000	1,765,973	1,826,986	1,890,111	1,950,356	2,003,802	2,003,802	2,003,802	2,003,802	2,003,802	2,003,802
Contenedores Secos Llenos	633,540	1,267,081	1,355,776	1,450,681	1,523,215	1,599,376	1,679,344	1,729,725	1,729,725	1,729,725	1,729,725	1,729,725	1,729,725
Vehiculos Movilizados	36,000	36,000	36,000	36,000	36,000	36,000	36,000	36,000	36,000	36,000	36,000	36,000	36,000
Carga Suelta (TON)	400,000	800,000	1,000,000	1,015,000	1,030,225	1,045,678	1,061,364	1,077,284	1,093,443	1,109,845	1,126,493	1,143,390	1,160,541
Carga Granel (TON)	1,000,000	1,500,000	1,522,500	1,545,338	1,568,518	1,592,045	1,615,926	1,640,165	1,664,767	1,689,739	1,715,085	1,740,811	1,766,923
Total TON	2,894,540	5,253,081	5,621,276	5,812,991	5,984,943	6,163,210	6,342,990	6,486,975	6,527,737	6,569,110	6,611,104	6,653,728	6,696,991
Movilización Carga (TEUs)													
TEUs Vacios Refrigerados	67,500	135,000	139,800	144,770	149,917	155,246	161,270	166,615	166,615	166,615	166,615	166,615	166,615
TEUs Llenos Refrigerados	82,500	165,000	170,700	176,597	182,699	189,011	195,036	200,380	200,380	200,380	200,380	200,380	200,380
Refrigerados Banano Expo	75,000	150,000	155,250	160,684	166,308	172,128	178,153	183,498	183,498	183,498	183,498	183,498	183,498
Refrigerados Otros Impto	7,500	15,000	15,450	15,914	16,391	16,883	16,883	16,883	16,883	16,883	16,883	16,883	16,883
TEUs Secos Vacios	10,000	20,000	21,400	22,898	24,043	25,245	26,507	27,303	27,303	27,303	27,303	27,303	27,303
TEUs Secos Llenos	60,000	120,000	128,400	137,388	144,257	151,470	159,044	163,815	163,815	163,815	163,815	163,815	163,815
Total TEUs	220,000	440,000	460,300	481,654	500,916	520,972	541,857	558,113	558,113	558,113	558,113	558,113	558,113

Source: PIO SAS, mayo 2015.

Table translation (First column)
Movilized load
Cargo type mobilized
40 Ft full refrigerated containers
Vehicles mobilized
Loose load
Bulk load
Mobilization load

	ENVIRONMENTAL LICENSE MODIFICATION FOR THE CONSTRUCTION AND OPERATION PROJECT OF A PORT TERMINAL OF SOLID BULK CARGOES IN THE MUNICIPALITY OF TURBO		
	PROJECT DESCRIPTION	Page 22 of 165	
	GAT-391-15-CA-AM-PIO-01	Revision:	

Empty refrigerated TEUs
Full refrigerated TEUs
Refrigerated Banana expo
Refrigerated others impo
Empty sacks TEUs
Full sacks TEUs

Vessels designs for the different purposes are listed in the following table:

Table Num. 3.5. Vessels designs

Source: Port Consultant Rotterdam, May 2015.



	1A - Initial	1A	2A	1B / 2B	1C	1D
Type	container	containers	containers	Bulk carriers	vehicles	Bulk carriers
Size	4–5,000 TEU	6–8,000 TEU	12,500 TEU	60,000 dwt	30,000 dwt	35,000 dwt
Lenght L _{oa} (m)	285	300	366	220	200	180
Beam B _s (m)	40.0	43.0	49.0	33.0	32.3	24
24loaded	13.0	14.5	15.2	12.7	11.0	10.5
Fretwork T (m)						

With the cargo projection and defined ship types, the dock positions and loading and unloading capacity is described below (Table Num. 3.6):

Table Num. 3.6. Mooring post capacity

Type of cargo	Direction	Equipment	Net Capacity ton per hr	Parcel size in MT	Amount of days per year	Amount of hours per day	Berth Occupancy in %	Capacity in ton per berth per year	
			TEU per hr	in TEU				in TEU Per year	
A	Containers	import / export	3xSTS cranes	120	5,000	350	21	60%	529,200
B	Grains /Fertilizers	Import	Mobile cranes (2)	400	40,000	300	21	70%	1,764,000
C	Cars	Import	none	300	250	350	21	70%	1,543,500
D	General Cargo	Import / export	ships gear (2)	100	10,000	350	21	70%	514,500
E	Project Cargo	Import	Mobile crane	50	10,000	350	21	70%	257,250

Source: Port Consultant Rotterdam, May 2015.

	ENVIRONMENTAL LICENSE MODIFICATION FOR THE CONSTRUCTION AND OPERATION PROJECT OF A PORT TERMINAL OF SOLID BULK CARGOES IN THE MUNICIPALITY OF TURBO	
	PROJECT DESCRIPTION	Page 23 of 165
	GAT-391-15-CA-AM-PIO-01	Revision:

3.2.3.1 Layout and geometric characteristics of the works to be built subject of the project

The project has two types of Works: offshore and on-shore. Offshore works are all works carried out in an aquatic environment and floodplains that must be supported on pillars above the mean sea level, including the junction with the platform or work yard on the mainland, and with the exception of the buoys. The on-shore works are those developed on land and that basically are the onshore terminal and the access road. In the Annex of Chapter 3 is the plan in basic engineering plant, which contains the characteristics of the works to be built.

3.2.3.1.1 Maritime dock

The dock is located on the western side of The León Riiver's mouth (approximately 1900 m¹). The orientation of the dock in Bahía Colombia is North - South. This dock will be built in two phases. The dock phase 1, is defined with the northern section of the dock and will consist of 340 m long and 200 m wide with availability of 5 berths. The dock phase 2, south section of the dock with a length of 300 m, for a total length of 640 m and a total of 8 berths. This dock is structurally defined by a platform built on piles and a concrete slab.



This platform consists of a large area of reinforced concrete, located at approximately 5.00 m above the average level of shallow waters of Sicigia MLWS, supported by metallic piles.

It must be taken into account for the designs and construction, that the Of-Shore platform will work for container ships, bulk ships, general cargo and RoRo operations for vehicle unloading. (See Figure Num. 3.9). As mentioned above, the dock is divided into two phases, taking into account that this configuration is subject to change according to what is stated in section 3.2.1.2).

Phase 1

- Dock 1A. - Container Dock.
- Dock 1B. - Bulk and General Cargo Dock.
- Dock 1C. - Roll-On / Roll-Off Dock for vehicles and General Cargo.

¹ The areas and lengths of the entire study are measured in the Magna Sirgas Origin Bogotá coordinate system

	ENVIRONMENTAL LICENSE MODIFICATION FOR THE CONSTRUCTION AND OPERATION PROJECT OF A PORT TERMINAL OF SOLID BULK CARGOES IN THE MUNICIPALITY OF TURBO	
	PROJECT DESCRIPTION	Page 24 of 165
	GAT-391-15-CA-AM-PIO-01	Revision:

- Dock 1D. - Bulk Dock.

Phase 2

- Dock 2A. - Container Dock.
- Dock 2B. - Bulk Dock.

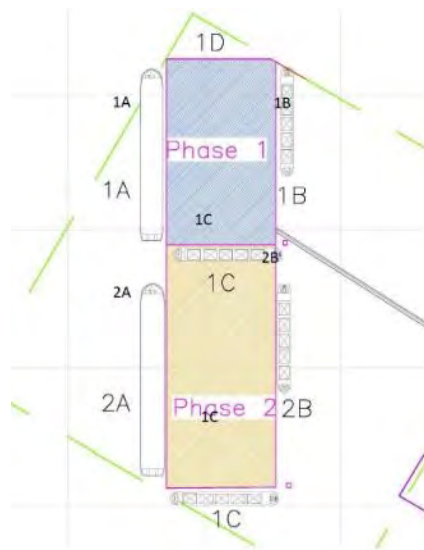



Figure Num. 3.9. Phases and number of docks in the Offshore platform

Sources: Consultant Port Rotterdam, May 2015

The configuration of piles in the dock is 70 inches in diameter, separated every 6.42 m from the axis in the north - south direction and 6.25 m in the east - west direction. The piles are metallic GR 60, with nominal thickness of 12 mm and thickness of corrosion 5.6 mm. For phase 1, approximately 1643 piles must be driven and 11457 for phase 2, for a total of 3100 piles on the dock.

	ENVIRONMENTAL LICENSE MODIFICATION FOR THE CONSTRUCTION AND OPERATION PROJECT OF A PORT TERMINAL OF SOLID BULK CARGOES IN THE MUNICIPALITY OF TURBO	
	PROJECT DESCRIPTION	Page 26 of 165
	GAT-391-15-CA-AM-PIO-01	Revision:

At the junction of this platform with the main platform, an expansion of enough amplitude must be foreseen to allow the expected movement of the main platform due to both, docking and earthquake. In this expansion, a sliding metal joint with a point load capacity corresponding to the maximum load of the cranes and/or vehicles that will pass through it must be provided.

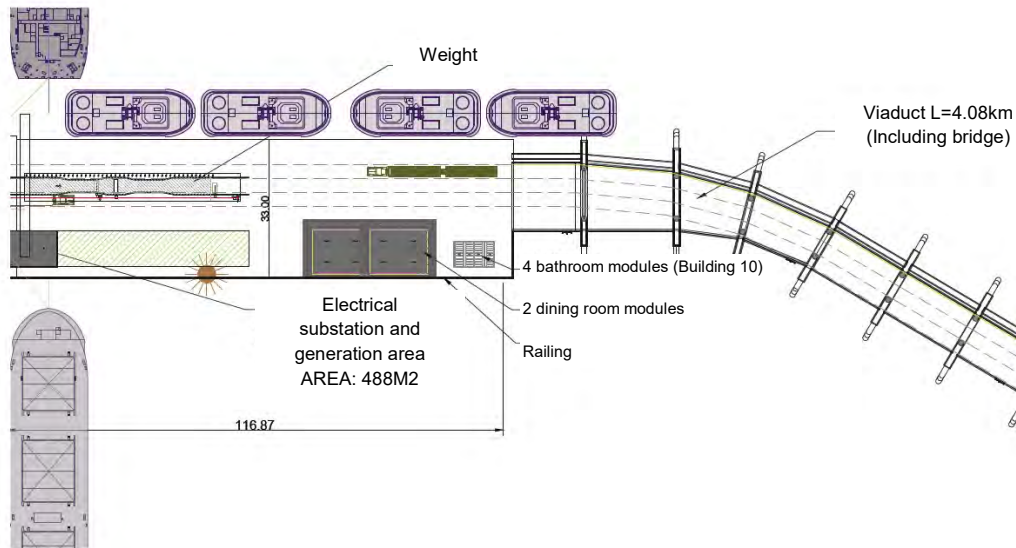



Figure Num. 3.11. Splice platform.
Sources: PIO SAS, September 2015.

3.2.3.1.3 Viaduct

To access, both vehicular and pedestrian from the facilities on land, an aerial footbridge (viaduct) has been provided at the same level of the dock for most of the route, except for the area of higher level necessary to ensure free navigation gauge of the Leon river on which the footbridge itself must be crossed in its terrestrial portion. Viaduct approved by ordinary turn ANLA 2015008528-2-001 of March 13, 2015.

The total estimated length of the whole, which originates in the terrestrial operations platform consisting of fillings and stabilizations up to the platform of the junction, is 4080 m, of which the first 1008 m are on the mainland, including the bridge, and the portion off shore with an extension of 3000 m.

	ENVIRONMENTAL LICENSE MODIFICATION FOR THE CONSTRUCTION AND OPERATION PROJECT OF A PORT TERMINAL OF SOLID BULK CARGOES IN THE MUNICIPALITY OF TURBO	 aqua & terra
	PROJECT DESCRIPTION	Page 27 of 165
	GAT-391-15-CA-AM-PIO-01	Revision:

The stretch over seawater includes two changes of horizontal alignment, two road interchanges to allow returns at intermediate points and a vertical break required to advance the connection ramp to the high point of the bridge over The León River, with a slope no greater than 3.5%.



The viaduct has a vehicular roadway consisting of three traffic lanes of 3.53 m wide each (10.60 m in total) and bordered by rails with New Jersey-type protection profile; an independent pedestrian walkway of 1.2 m of useful width and two linear loading corridors, the first on the left margin (south and south west) destined to the location of liquid handling lines (potable water, sanitary, fuels and liquid products) bulk (not hydrocarbons)) with a useful width of 3.35 m and the second on the north and north-east side with an approximate width of 3.3 m, destined for a future bi-directional solid handling band of high capacity (greater than 2000 t / hour) with its corresponding inspection and maintenance covers and walkways.

At the outer end against the splice platform, the roadway will be widened to achieve 4 effective lanes that facilitate the flow of vehicles to and from the aforementioned platform (see Figure Num. 3.12).

In the final 70 m, connecting the splice platform, the circulation section is gradually extended from 3 to 4.5 lanes (4 lanes of 3.5 m + central spacer of 1.75 m for a total of 15.75 m) to facilitate bidirectional flow as a transition to traffic flows and traffic control and weighing operations on the platform itself (see Figure Num. 3.11). Thus, the respective extension of the transverse beams will be carried out to maintain the lateral corridors of bulk transport and pipes.

Between the vehicular corridor and the pedestrian corridor, a strip has been planned for the conduction of the electrical and communications networks supported in both structures (vehicular and pedestrian) to supply the respective services towards the sea operations platform at sea.

The estimated total width of the set of walkways and corridors is 20 m, and will consist of a system supported on pillars driven on sea level at approximately 5.00m minimum.

	ENVIRONMENTAL LICENSE MODIFICATION FOR THE CONSTRUCTION AND OPERATION PROJECT OF A PORT TERMINAL OF SOLID BULK CARGOES IN THE MUNICIPALITY OF TURBO	
	PROJECT DESCRIPTION	Page 28 of 165
	GAT-391-15-CA-AM-PIO-01	Revision:

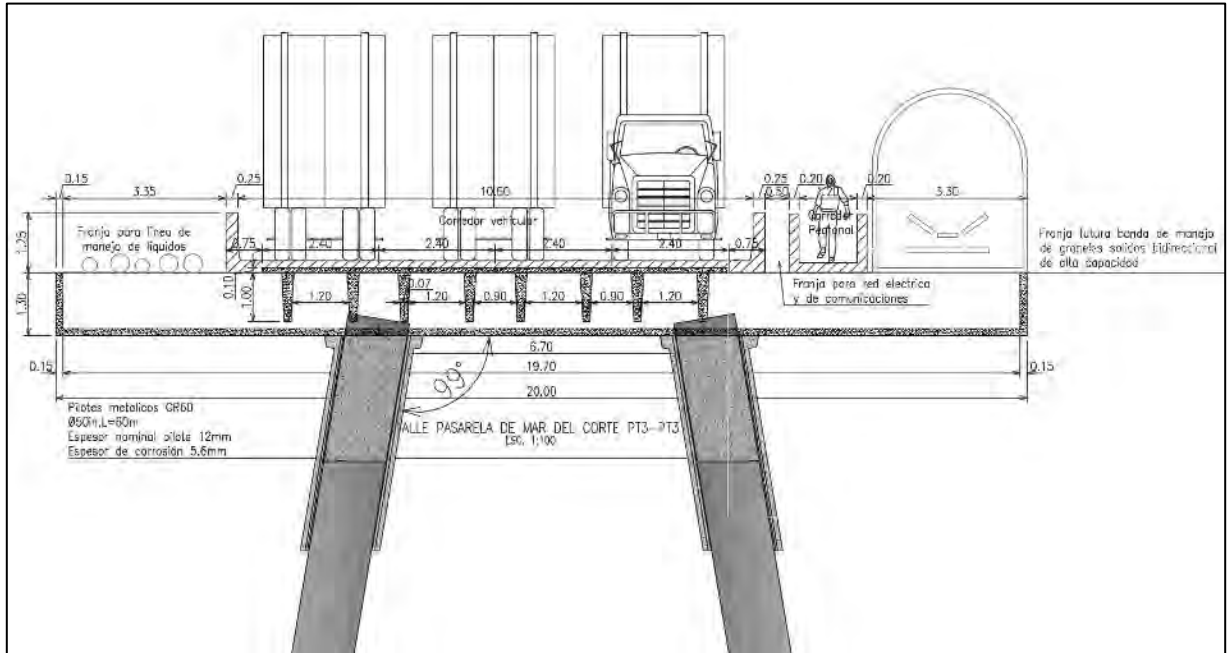



Figure Num. 3.12. Section of the viaduct
PIO SAS Sources, September 2015.

The initial portion of the viaduct on land will initially be distributed 380m from the terminal on land, connected to a bridge of 137.91 m of free length on the León River where it must have a free clearance of 15.0 m above the mean level of said river, to guarantee your current navigability. Finally 490m on land, for a total of 1008m.

The initial portion of approximately 380 m in length will be formed on an ascending ramp to reach from the onshore platform at approximately 2.00m above the mean sea level to the approximate level of +16.00 above the mean sea level on the bridge same with slope equal to or less than 3.5%.

	ENVIRONMENTAL LICENSE MODIFICATION FOR THE CONSTRUCTION AND OPERATION PROJECT OF A PORT TERMINAL OF SOLID BULK CARGOES IN THE MUNICIPALITY OF TURBO	
	PROJECT DESCRIPTION	Page 29 of 165
	GAT-391-15-CA-AM-PIO-01	Revision:

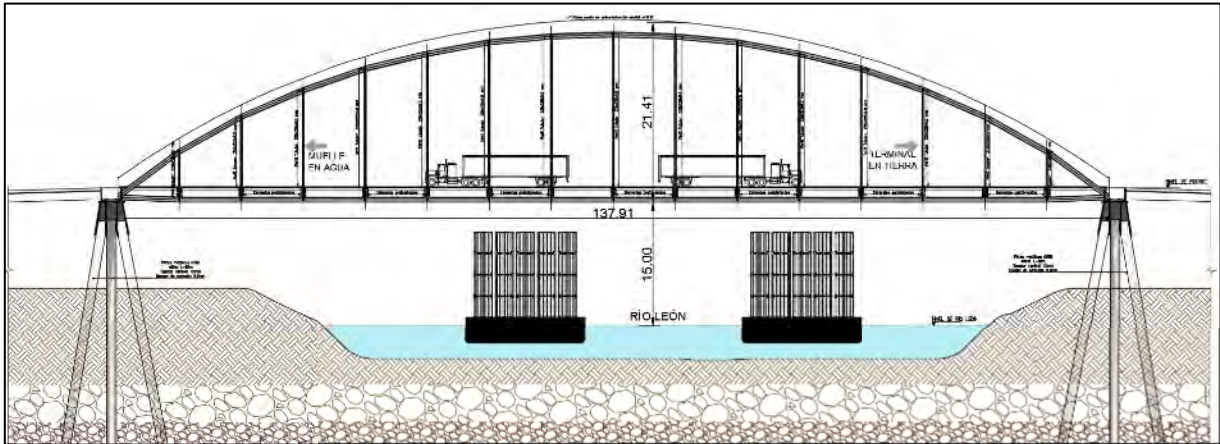



Figure Num. 3.13. Bridge over The León Riiver
PIO SAS Sources, September 2015.

3.2.3.1.4 Fluvial Dock

Initially in the construction stage, a dock will be built on the north bank of the artificial channel of Nueva Colonia, within the extension of the Puerto Bahía Colombia de Urabá site; in accordance with that authorized in resolution 0032 of January 25, 2012, with the main purpose of supporting the phase I constrictive execution. In addition, it will facilitate future construction phases, and to handle special oversized loads that cannot be served from the main docking platform.

The fluvial dock is 100m long and 12m wide (see Figure Num. 3.14), in such a way as to allow the operation of cranes with a current effective draft of not less than 2m in minimum depth waters of the river, where slabs and barges of shallow draft but high load capacity can be served, between 1000 and 2000 t / barge. As well as mooring auxiliary navigation equipment such as personnel launches, transport of port pilots, etc..

It is important to mention that this dock is licensed according to resolution 0032 of January 25, 2012.

	ENVIRONMENTAL LICENSE MODIFICATION FOR THE CONSTRUCTION AND OPERATION PROJECT OF A PORT TERMINAL OF SOLID BULK CARGOES IN THE MUNICIPALITY OF TURBO	
	PROJECT DESCRIPTION	Page 30 of 165
	GAT-391-15-CA-AM-PIO-01	Revision:

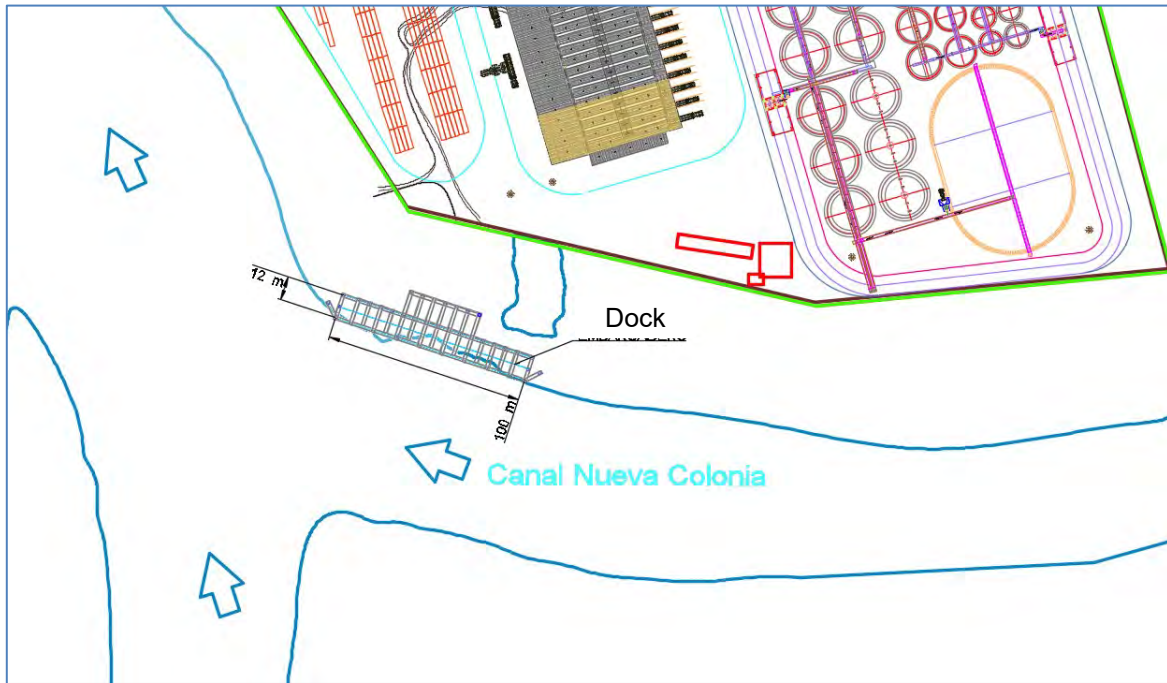



Figure Num. 3.14. Dock on the north shore of the artificial Channel of Nueva Colonia.
PIO SAS Sources, September 2015.

3.2.3.1.5 Onshore terminal

The facility executed on land will be developed in an area of 35 ha, in which the distribution of port facilities will be made, such as: entrance portal, storage yards for dry containers (full and empty) and refrigerated, container handling, vehicle import yard, bulk area, parking areas, buildings, roads, expansion area, substations, among others (see Figure Num. 3.15). The list of distribution of areas is referenced in the Table Num. 3.3.

	ENVIRONMENTAL LICENSE MODIFICATION FOR THE CONSTRUCTION AND OPERATION PROJECT OF A PORT TERMINAL OF SOLID BULK CARGOES IN THE MUNICIPALITY OF TURBO	
	PROJECT DESCRIPTION	Page 31 of 165
	GAT-391-15-CA-AM-PIO-01	Revision:

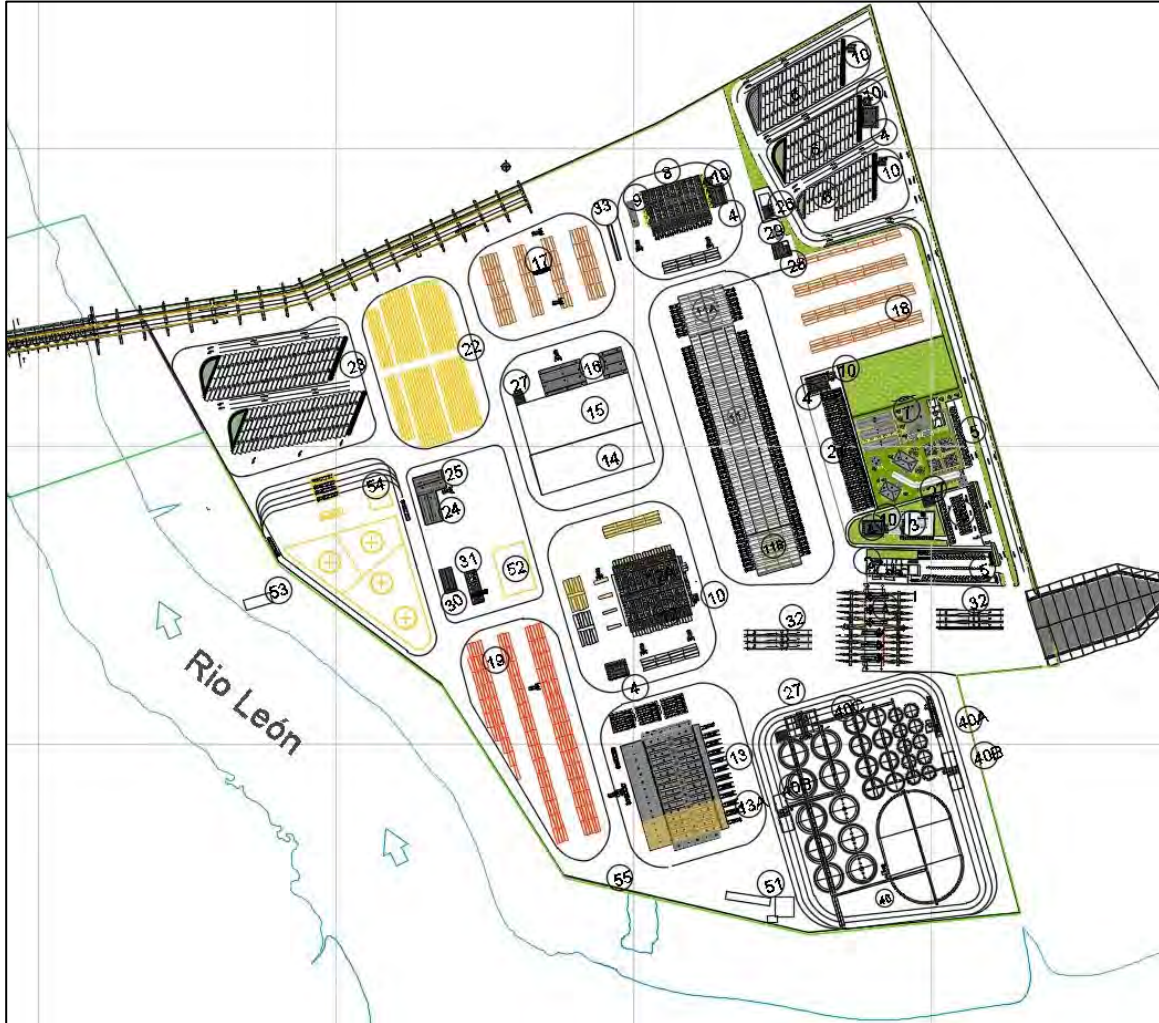



Figure Num. 3.15. Onshore Terminal.
PIO SAS Sources, September 2015.

The final finishes and outer floors of the onshore terminal for phase are: pavement, soil improvement and areas without intervention. The internal connection routes are designed to the criteria of mobility and operation of the port. The bulk area will be built in future phases.

	ENVIRONMENTAL LICENSE MODIFICATION FOR THE CONSTRUCTION AND OPERATION PROJECT OF A PORT TERMINAL OF SOLID BULK CARGOES IN THE MUNICIPALITY OF TURBO	
	PROJECT DESCRIPTION	Page 32 of 165
	GAT-391-15-CA-AM-PIO-01	Revision:

3.2.3.1.6 Dredging

The dredging areas related in this project correspond to the areas that guarantee the access of the vessels that will operate on the dock.

These areas are known as: access channel, maneuvering dock and berth positions.

The configuration of the areas and the respective levels will be established according to the berthing lines, type of vessel and phases of the project. In such a way that the levels of dredging defined for container ships that dock to the western dock is -16.70 m, for the rest of bulk vessels, vehicle and general cargo the level of dredging is -13.70 m (Figure Num. 3.16).

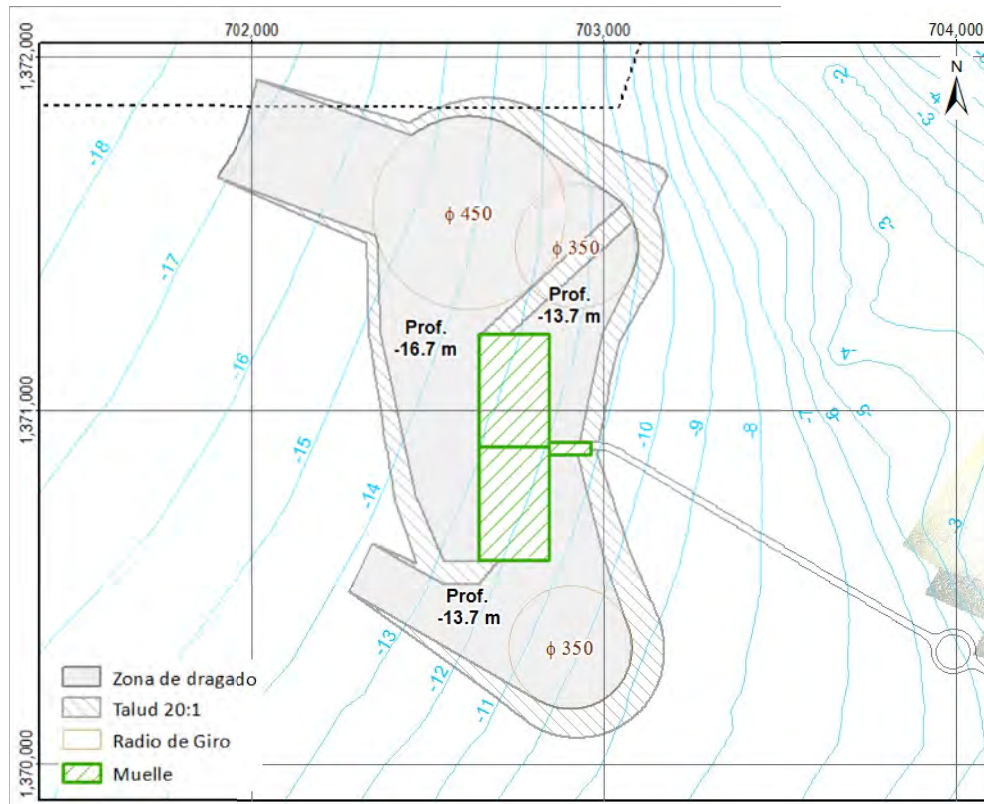

Figure Num. 3.16. Dredging areas.
Source: Aqua & Terra Consultores SAS.

From a sedimentation analysis in the anchoring areas and The León Riiver's mouth, between 2001 and 2012 (Álvarez 2011), sedimentation levels were established (Table Num. 3.7).



	ENVIRONMENTAL LICENSE MODIFICATION FOR THE CONSTRUCTION AND OPERATION PROJECT OF A PORT TERMINAL OF SOLID BULK CARGOES IN THE MUNICIPALITY OF TURBO	
	PROJECT DESCRIPTION	Page 33 of 165
	GAT-391-15-CA-AM-PIO-01	Revision:

Table Num. 3.7. Calculation of the sedimented volume between 2001 and 2012 in the anchoring zone.

SEDIMENTACIÓN ZONA DE FONDEO			
Sector	Volumen 2001 – 2012 (m3)	Volumen anual (m3)	% vol. Respecto vol del canal (tabla 4.2)
Noreste	1.091.674	99.245	3.0
Suroeste	1.355.729	123.248	3.5
Total	2.447.403	222.491	6.5

Source: Álvarez (2011).

As evidenced in the Table Num. 3.7, The volume of sedimentation in the southwest sector of the anchorage is around 1 million cubic meters (1,000,000 m³) between 2001 and 2012, which can be considered as a low sedimentation rate.

It is clarified that these sedimentation calculations were not determined with the dock and new projected depths in the area. However, as described in the documents of Álvarez (2011)² and Molares (2012)³, the sedimentation rates are low, therefore a minimum maintenance dredging is expected.



On the other hand, the dredging that will be carried out in this area will be developed with a suction-type dredge running TSHD (Trailing Suction Hopper Dredge), taking into account that the bottom material corresponds to clays and loose silts (mud). The volume of dredging is 2'794,375 m³. The cutting slope for dredging has been defined 1V: 20H.

This dredging activity will be executed depending on the commercial needs of the port. In this way, initially the port will have access to vessels that comply with the draft in natural conditions such as:

- Container ships with capacity less than 4000 TEU
- Bulk carrier of 40,000 DWT
- General cargo ship of 35,000 DWT

² Morphodynamic modeling of intra-annual estuaries, Oscar Álvarez, National University of Colombia, Medellín Headquarters, 2011



³ Oceanographic and hydrosedimentary study of the mouth of the León River and its impact on the mooring area of Bahía Colombia, Ricardo Molares, October 2012.

	ENVIRONMENTAL LICENSE MODIFICATION FOR THE CONSTRUCTION AND OPERATION PROJECT OF A PORT TERMINAL OF SOLID BULK CARGOES IN THE MUNICIPALITY OF TURBO	
	PROJECT DESCRIPTION	Page 34 of 165
	GAT-391-15-CA-AM-PIO-01	Revision:

Once the port has access to larger vessels, this activity will be executed in full taking into account that the duration of the dredging and disposal takes approximately 120 days.

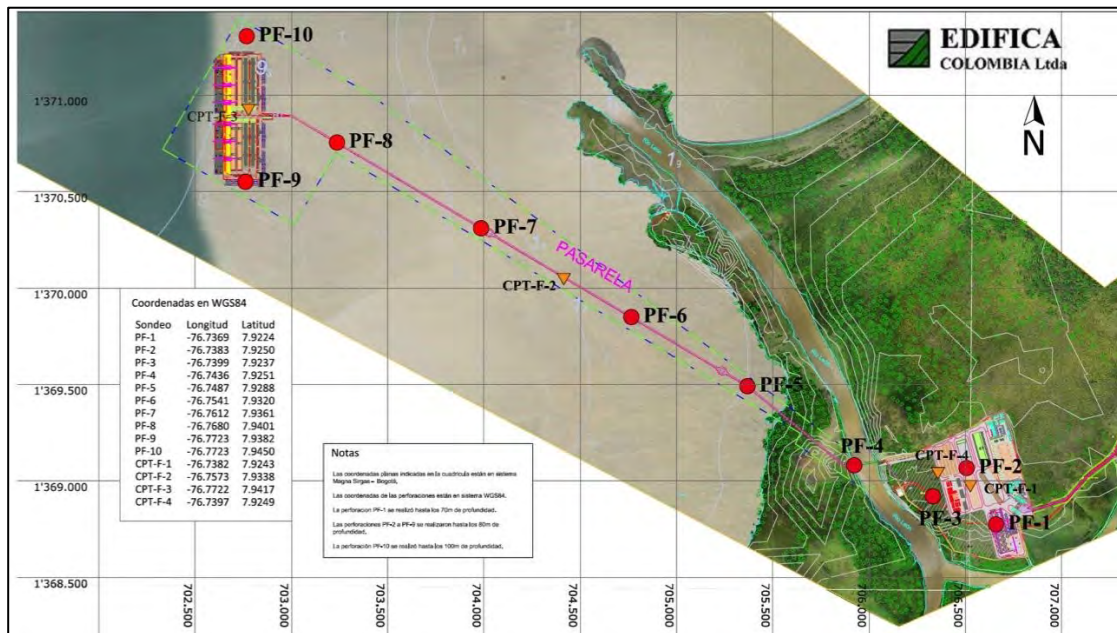
The detailed description of the physicochemical quality of the sediments is described in the chapter on the characterization of the area of influence, in the subchapter of marine sediment quality..



	ENVIRONMENTAL LICENSE MODIFICATION FOR THE CONSTRUCTION AND OPERATION PROJECT OF A PORT TERMINAL OF SOLID BULK CARGOES IN THE MUNICIPALITY OF TURBO	
	PROJECT DESCRIPTION	Page 35 of 165
	GAT-391-15-CA-AM-PIO-01	Revision:

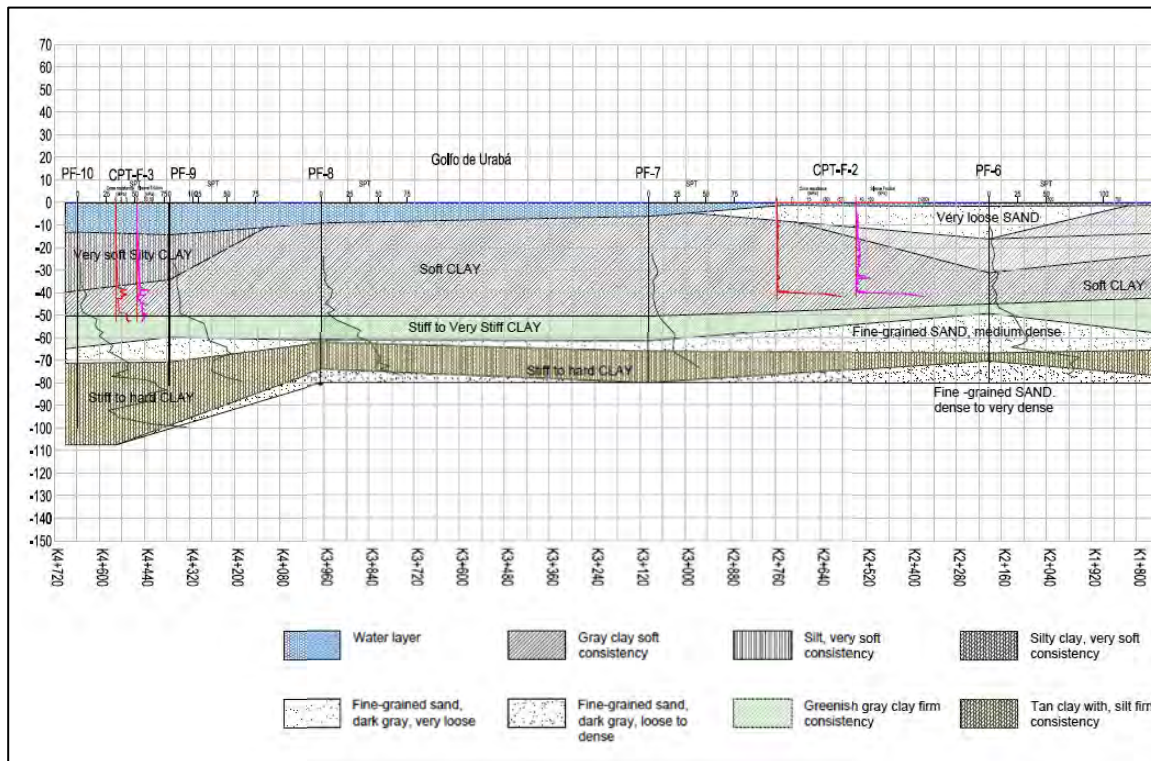

Figure Num. 3.17. Geotechnical drilling and stratigraphic profile.
Source: Edifica, Geotechnical Study, June 2015.



The type of soil or bottom material in the dredging area is classified as soft silty clay, characteristic of a muddy material (see Figure Num. 3.17)⁴.

On the other hand, the location of the dump follows the next criteria:

- That the dump does not impact the coastline dynamics.
- That the selected area does not affect the conditions of navigability and anchoring of the bay.
- Do not affect fishing grounds.

In section 3.2.7 of this chapter, a detailed description of the impact on littoral dynamics has been developed for the location of the dump. However, in Figure Num. 3.18 and Table Num. 3.8, location and coordinates of the dump are presented.

⁴ Edifica, Geotechnical Study for Conceptual Engineering, June 2015.

	ENVIRONMENTAL LICENSE MODIFICATION FOR THE CONSTRUCTION AND OPERATION PROJECT OF A PORT TERMINAL OF SOLID BULK CARGOES IN THE MUNICIPALITY OF TURBO	
	PROJECT DESCRIPTION	Page 36 of 165
	GAT-391-15-CA-AM-PIO-01	Revision:

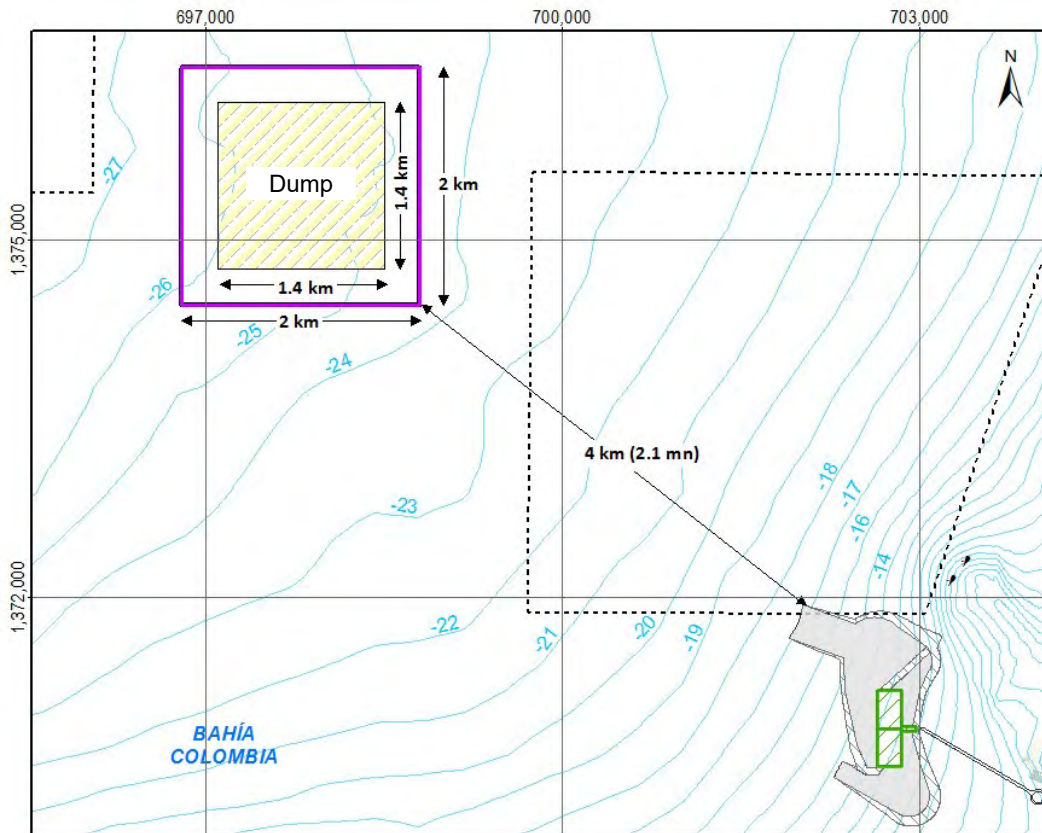
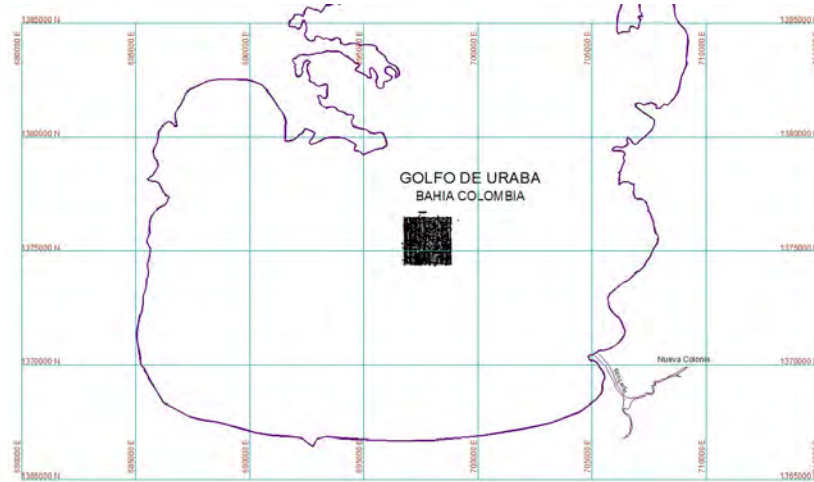

Figure Num. 3.18. Location of the dump.
Source: Aqua & Terra Consultores Asociados SAS.



	ENVIRONMENTAL LICENSE MODIFICATION FOR THE CONSTRUCTION AND OPERATION PROJECT OF A PORT TERMINAL OF SOLID BULK CARGOES IN THE MUNICIPALITY OF TURBO	
	PROJECT DESCRIPTION	Page 37 of 165
	GAT-391-15-CA-AM-PIO-01	Revision:

Table Num. 3.8. Coordinates of the dump area.

APEX	COORDINATES MAGNA SIRGAS Origen BOGOTÁ	
	EAST (m)	NORTH (m)
B1	698.497,53	1.376.155,75
B2	698.497,53	1.374.755,75
B3	697.097,53	1.374.755,75
B4	697.097,53	1.376.155,75



Source: Aqua & Terra Consultores asociados, 2015

- **Description of dredging activity**

Before commencing the dredging activities, a precision bathymetric survey will be carried out using an echo sounder, recording position and depth data along the area to be dredged. Once the bathymetric measurements have been obtained, all the data will be processed to obtain the morphometric characteristics of the soil to be dredged, in order to plan the dredging activities.

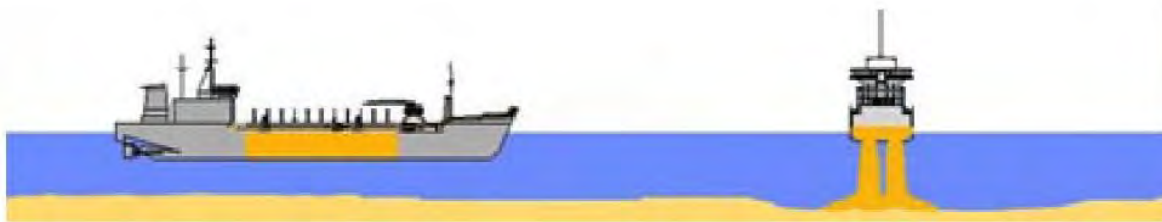
For the dredging of the channel, a suction hopper dredger will be used. In general, these dredges have a satellite positioning system in real time, a system that allows them to be located in areas to be dredged.



	ENVIRONMENTAL LICENSE MODIFICATION FOR THE CONSTRUCTION AND OPERATION PROJECT OF A PORT TERMINAL OF SOLID BULK CARGOES IN THE MUNICIPALITY OF TURBO	
	PROJECT DESCRIPTION	Page 38 of 165
	GAT-391-15-CA-AM-PIO-01	Revision:

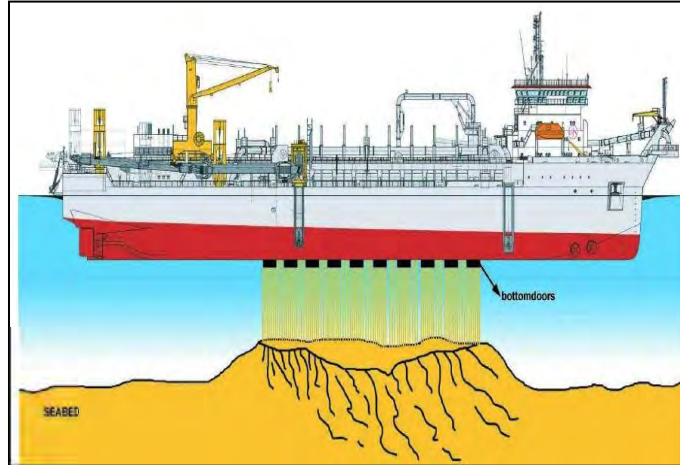

Figure Num. 3.19. The method of unloading dredged material in dump.

Source: taken from Boskalis dredging & Marine Experts, Capability Sheet TSHD y JAN DE NUL GROUP⁵



Once the equipment is located in the area to be dredged, the dredging arms are lowered to the bottom, proceeding to initiate the suction of the material, driving it, by means of pumping and pipelines, to the hopper of the dredge. This procedure is carried out until the hopper of the dredger is completely full.



Once the hopper is full, or the operational draft is reached, the dredge will begin to navigate to the authorized dump area. Once in the dump, the dredger opens the bottom gates so that the dredged material comes out and is deposited in the dump. After the unload, the dredge returns to the dredging area repeating the operation described above, until it reaches the entire dredging, in accordance with the dredging designs of the maneuvering area and the access channel to the maritime dock.

In Table Num. 3.9 We present some of the dredges available in the market to develop this activity, with its main characteristics.

Table Num. 3.9. List of equipment that could be used depending on availability in the market

⁵ JAN DE NUL. [online] <http://www.jandenul.com>.

	ENVIRONMENTAL LICENSE MODIFICATION FOR THE CONSTRUCTION AND OPERATION PROJECT OF A PORT TERMINAL OF SOLID BULK CARGOES IN THE MUNICIPALITY OF TURBO	
	PROJECT DESCRIPTION	Page 39 of 165
	GAT-391-15-CA-AM-PIO-01	Revision:

Type of dredger	Photography	Features
TSHD		Hopper: 12.000 m ³ . Length (Loa): 145 m Beam: 27.5 m Draft with load (D): 10.0 m
TSHD		Hopper: 11.750 m ³ . Length (Loa): 144.0 m Beam: 25.5 m Draft with load (D): 9.7 m
TSHD		Hopper: 14.000 m ³ . Length (Loa): 147.8 m Beam: 30.0 m Draft with load (D): 11.2 m



Source: taken from Boskalis dredging & Marine Experts, Capability Sheet TSHD y JAN DE NUL GROUP⁶

- **Characteristics of the dredging process**

The main characteristics of the dredging activity for the maneuver and access channel areas are listed below:

- The considered dump is located 4.1 km from the dredging area.
- The barge will take a speed of 8 knots to carry the cargo from the dredging area to the dump.

⁶ JAN DE NUL. [online] <http://www.jandenul.com>.

	ENVIRONMENTAL LICENSE MODIFICATION FOR THE CONSTRUCTION AND OPERATION PROJECT OF A PORT TERMINAL OF SOLID BULK CARGOES IN THE MUNICIPALITY OF TURBO	
	PROJECT DESCRIPTION	Page 40 of 165
	GAT-391-15-CA-AM-PIO-01	Revision:

- The target level to reach in the dredging area is -16.7 and -13.7 m (see Figure Num. 3.16).
- The dredging volume is 1.1 m³ / s with 30% solids, generating a solid dredging volume of 0.33 m³ / s.
- The percentage of solids in the volume of the barge is 40%.
- The filling time of the barge is 4.04 hours.
- The dredging will be done by overflow in order to optimize the dredging times.
- The daily sediment yields are 23318 m³ / d
- The approximate net time of the dredging activity is 120 days.

3.2.3.2 Constructive process

3.2.3.2.1 Fluvial Dock



The construction process of the temporary dock consists of the following activities:

- Pile driving: The piles for this dock will be GR60 metal with a diameter of 50 "and a length of 15 m, separated by a distance between 6 and 12 m in length, its nominal thickness is 12 mm with a corrosion thickness of 5.6 mm.
- Installation of chapters
- Installation of beams
- Emptying knots
- Installation of prefabricated slabs
- Top slab casting

3.2.3.2.2 Land preparation

Before starting any stabilization procedure, the land must be in optimal conditions, which constitute the following activities:

- Disassembly and cleaning
- Demolition and Removal
- Excavation of the grading: includes stripping and removal of inappropriate material

	ENVIRONMENTAL LICENSE MODIFICATION FOR THE CONSTRUCTION AND OPERATION PROJECT OF A PORT TERMINAL OF SOLID BULK CARGOES IN THE MUNICIPALITY OF TURBO	
	PROJECT DESCRIPTION	Page 41 of 165
	GAT-391-15-CA-AM-PIO-01	Revision:

3.2.3.2.3 Disassembly and Cleaning

This work consists of the clearing and cleaning of natural terrain in the areas that will occupy the land works, which are covered with stubble, forest, pastures, etc., including the removal of roots, debris and garbage. It also includes, the final disposal inside or outside the project area, of all the materials coming from the operations described above.





Photo Num. 3.1 Disassembly and cleaning
Source: PIO SAS, septiembre 2015.

3.2.3.2.4 Demolition and removal

It consists of the total or partial demolition of existing structures and the removal, loading, transport, unloading and final disposal of the materials coming from the demolition. Initially, for the existing works will be used during the construction process and will be demolished in the transfer of the construction of the onshore terminal phase 1.

3.2.3.2.5 Excavation of the grading

	ENVIRONMENTAL LICENSE MODIFICATION FOR THE CONSTRUCTION AND OPERATION PROJECT OF A PORT TERMINAL OF SOLID BULK CARGOES IN THE MUNICIPALITY OF TURBO	
	PROJECT DESCRIPTION	Page 42 of 165
	GAT-391-15-CA-AM-PIO-01	Revision: <input type="text"/>

It consists in excavating, removing, loading and transporting the materials coming from the cuts required for the grading, channels and loans. It also includes stripping on the areas where excavations of the grading and embankments will be carried out.



Photo Num. 3.2. Excavation of grading and stripping

Source: PIO SAS, septiembre 2015.



3.2.3.2.6 Soil stabilization Prefabrication yard and storage of materials

Stabilization is a technique used to modify the properties of an unsuitable soil in some sense, which must be used for a specific purpose, in a specific place and make it capable of meeting better requirements. Next, the different procedures that will be used to achieve soil improvement are described.

Before deciding or implementing any type of improvement or reinforcement of the land, the initial conditions of the terrain must be adequately established, through the appropriate geotechnical study. The procedure to be used will be according to the designs and the decision of the builder.

- **Stabilization by compaction**

The procedure for stabilization by compaction is described below:

	ENVIRONMENTAL LICENSE MODIFICATION FOR THE CONSTRUCTION AND OPERATION PROJECT OF A PORT TERMINAL OF SOLID BULK CARGOES IN THE MUNICIPALITY OF TURBO	
	PROJECT DESCRIPTION	Page 43 of 165
	GAT-391-15-CA-AM-PIO-01	Revision:

- Selection of the appropriate borrowed filling material
- Poured and extended soil in layers of a few centimeters
- Modification of soil moisture (humidification or aeration)
- Compaction of each layer with roller compactors, tire compactors, sheepsfoot roller or vibratory machines.
- **Stabilization with preload**



This method consists of overburdening a land superficially through the contribution of land, which results in a load greater than that which is going to be subjected to service. In this way the achievement of the settlements of services and obtaining an acceptable residual seat is accelerated.

- Stack the filling material on the ground and leave it for some time
- Remove the filling

- **Stabilization with gravel columns**

This method of soil improvement is carried out through the densification and reinforcement of the soil, which consists in the incorporation of the vertical element terrain constituted by compacted material by means of a vibrator, in order to form flexible inclusions (see Figure Num. 3.20). This method has the advantage that, in addition to reinforcing the ground, it improves its drainage conditions.

- Introduce the vibrator until reaching the required depth
- Filling with granular material without fines (gravel) the resulting gap
- Finishings

	ENVIRONMENTAL LICENSE MODIFICATION FOR THE CONSTRUCTION AND OPERATION PROJECT OF A PORT TERMINAL OF SOLID BULK CARGOES IN THE MUNICIPALITY OF TURBO	
	PROJECT DESCRIPTION	Page 44 of 165
	GAT-391-15-CA-AM-PIO-01	Revision:

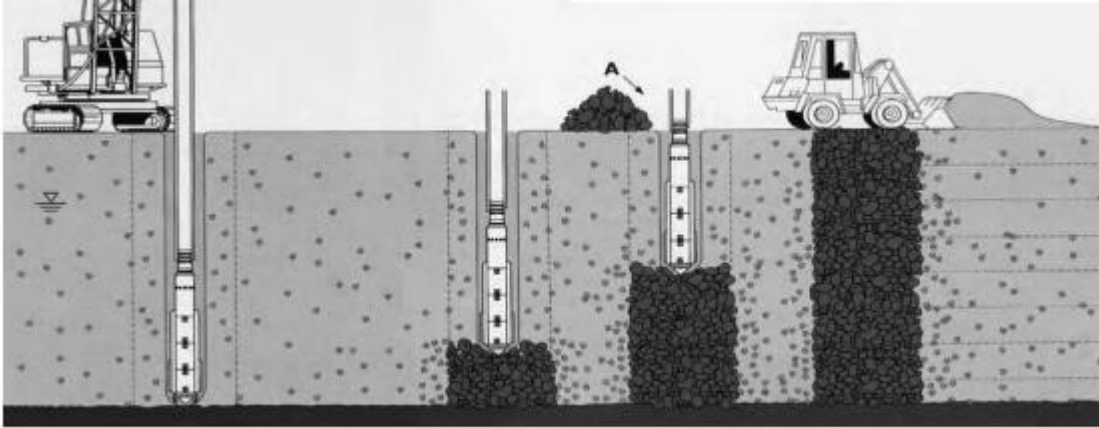

Figure Num. 3.20. Stabilization by gravel columns



Source: Edifica, **Geotechnical Study**, June 2015.

This process can be "wet" by pressurized water released or "dry" with the help of compressed air, and in both cases the supply of the material provided can be from the surface or the bottom.

- **Stabilization by vibrocompaction**

In this method the terrain is not replaced and is ideal for large loads on the improved soils and also for dynamic loads. The construction phases are:

- Piling: The vibrator descends due to the combined effect of weight, vibration and water injection.
- Compaction: By successive passes from bottom to top. To compact a cylinder of more or less 5 meters in diameter is used.
- Contribution of materials: Ground is added to compensate the sinking cone around the vibrator.
- Finishing: The platform is leveled and becomes a compact with roller.

	ENVIRONMENTAL LICENSE MODIFICATION FOR THE CONSTRUCTION AND OPERATION PROJECT OF A PORT TERMINAL OF SOLID BULK CARGOES IN THE MUNICIPALITY OF TURBO	
	PROJECT DESCRIPTION	Page 45 of 165
	GAT-391-15-CA-AM-PIO-01	Revision:

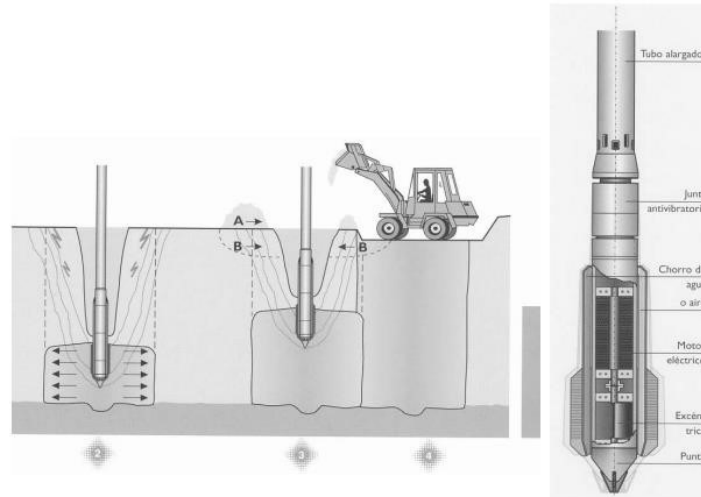



Figure Num. 3.21. Stabilization by vibrocompaction
Source: Edifica, Geotechnical Study, June 2015

- **Stabilization with jet Grouting**

It consists of the formation of pseudo-cylinder columns of soil-cement, with additives capable of withstanding rupture stresses in the laboratory of up to 200 kg / cm². Its execution is developed in 2 phases:

- Drilling to the final level
- The fluid is injected and the pipe is recovered simultaneously
- The process is repeated as many times as necessary

	ENVIRONMENTAL LICENSE MODIFICATION FOR THE CONSTRUCTION AND OPERATION PROJECT OF A PORT TERMINAL OF SOLID BULK CARGOES IN THE MUNICIPALITY OF TURBO	
	PROJECT DESCRIPTION	Page 46 of 165
	GAT-391-15-CA-AM-PIO-01	Revision:

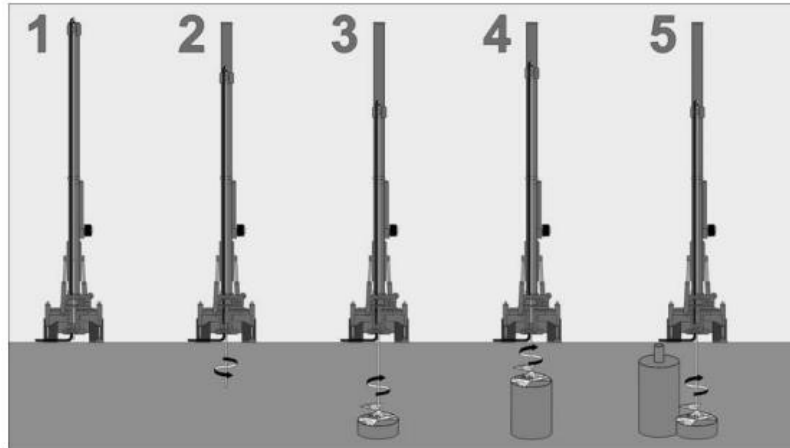

Figure Num. 3.22. Stabilization with jet-grouting
Source: Edifica, Geotechnical Study, June 2015.

3.2.3.2.7 Final onshore terminal



This activity starts from the stabilization of the soil to later build an embankment that allows to reach the level of the desired terrain for the operation of the dock. Once reached this level proceeds with the construction of the proposed facilities for this sector.

Once stabilized and prepared the land on which the embankment will settle, it will proceed to the construction, using materials that meet the conditions required for each area. The execution of the embankment consists of 3 operations that are repeated cyclically for each layer, until reaching the assigned level; These are: Spread out, humidification and compaction.

Spread out: The soil will be spread in layers of uniform thickness of 20 to 25 cm and parallel to the esplanade. The material of each layer should be uniform and uniform.

Moistening: After making the spread of the material if the soil was very dry according to the specified moisture of the material to be compacted, it can be moistened by traditional irrigation systems until it reaches a condition of $\pm 2\%$, with respect to the optimum humidity of compaction, obtained in the laboratory by means of the proctor test.

Compaction: It will be compacted initially with motor grader up to the finishing level, finally to guarantee the carrying capacity of the material, a compaction will be done with a roller compactor kickstand, and / or vibratory roller depending on the type of material, which is looking for a density that meets the proctor. To complete this

	ENVIRONMENTAL LICENSE MODIFICATION FOR THE CONSTRUCTION AND OPERATION PROJECT OF A PORT TERMINAL OF SOLID BULK CARGOES IN THE MUNICIPALITY OF TURBO	
	PROJECT DESCRIPTION	Page 47 of 165
	GAT-391-15-CA-AM-PIO-01	Revision:

operation, it must comply with the verification of the quality of the material that has been controlled by the laboratory and the levels that must be controlled by the topography.

3.2.3.2.8 Construction of the maritime terminal and viaduct

- **Pile driving**

For the construction of this dock will be used metal piles, cylindrical and with diameters between 50 and 70 "and lengths between 65 and 75 m.

Getting the raw material can be done in two ways: Importing steel sheets and subsequently producing the piles in a workshop on site or importing the piles.

The constructive process of piles driving with precise location, by means of the help of a GPS system, is located initially at the coordinate where the first pile will be driven.

In order to start the pile driving process, a floating platform called bongos or barges is required, which must be anchored in the appropriate place according to the coordinate. In this will install the crane equipped with the appropriate hammer to perform this activity.

At the same time, a metal structure, which has the angle of inclination with which the pile should be driven, should be placed on the site where the pile will be driven, since it will serve as a guide.

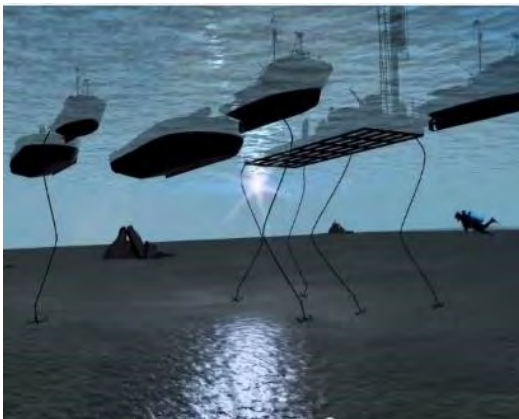





Figure Num. 3.23. Anchorage of barges and location and transport of piles

Source: PIO SAS, September 2015.

	ENVIRONMENTAL LICENSE MODIFICATION FOR THE CONSTRUCTION AND OPERATION PROJECT OF A PORT TERMINAL OF SOLID BULK CARGOES IN THE MUNICIPALITY OF TURBO	
	PROJECT DESCRIPTION	Page 48 of 165
	GAT-391-15-CA-AM-PIO-01	Revision:

After having defined the coordinates of where the pile will be begins with the driving of the same. Process that will be described below:

- With the help of the crane, the pile is lifted and placed in the proper position.
- After this begins with the pile driving, this will be done to the depth agreed in the geotechnical study.
- The above procedure is repeated until you have a certain number of piles, which are such, that you can mount a metal platform where the crane will be installed to continue the process of driving.
- The metallic platform will be installed to speed up the process of driving and provide greater stability to the crane.
- As the metal platform moves, the prefabricated ring or capital will be installed on the top of the pile.
- In the transition of the installation of the capitals, the installation of the prefabricated beams will begin. Which will rest on the capitals.
- When all the beams are already installed, the knots must be emptied to ensure the correct union between elements.
- When all the beams are already installed, the knots must be emptied to ensure the correct union between elements.
- After the melting of the knots, the installation of the prefabricated slabs begins.
- After having all the panels installed, concrete is emptied to obtain a more homogeneous surface and facilitate the transport of containers.

	<p align="center">ENVIRONMENTAL LICENSE MODIFICATION FOR THE CONSTRUCTION AND OPERATION PROJECT OF A PORT TERMINAL OF SOLID BULK CARGOES IN THE MUNICIPALITY OF TURBO</p>	
	<p align="center">PROJECT DESCRIPTION</p>	<p align="right">Page 49 of 165</p>
	<p align="center">GAT-391-15-CA-AM-PIO-01</p>	<p>Revision: <input type="text"/></p>



a. Placement of the pile in position to be driven



b. Pile driving



c. Metallic platform and crane installed





d. Capital or prefabricated ring installed in the pile



e. Installed beams



f. Emptying knots

	ENVIRONMENTAL LICENSE MODIFICATION FOR THE CONSTRUCTION AND OPERATION PROJECT OF A PORT TERMINAL OF SOLID BULK CARGOES IN THE MUNICIPALITY OF TURBO	
	PROJECT DESCRIPTION	Page 50 of 165
	GAT-391-15-CA-AM-PIO-01	Revision:

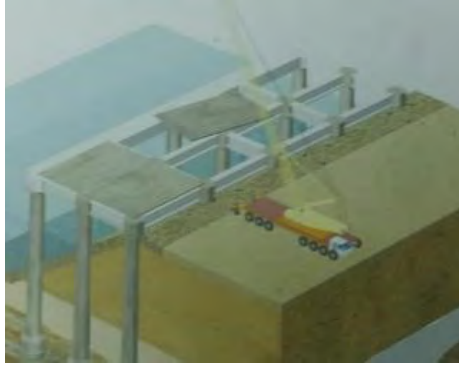

g. Installation of prefabricated slabs



h. Top slab casting

Figure Num. 3.24. Maritime dock and viaduct construction process.
Source: PIO SAS, September 2015.

After the upper slab has been set, the bitts and fenders are installed to complete the construction process of the dock.



Photo Num. 3.3. Installed bit ton a dock
Source: PIO SAS, September 2015.

3.2.3.2.9 Access road

In order to facilitate the construction process of the works, the improvement of the existing road (from the new colony to the port) must be made over a length of approximately 2.46 km and a bench of 10.3 m. This improvement must take into account the specifications for the transit of cargo vehicles and consists of the supply,

	ENVIRONMENTAL LICENSE MODIFICATION FOR THE CONSTRUCTION AND OPERATION PROJECT OF A PORT TERMINAL OF SOLID BULK CARGOES IN THE MUNICIPALITY OF TURBO	
	PROJECT DESCRIPTION	Page 51 of 165
	GAT-391-15-CA-AM-PIO-01	Revision:

transport, placement and compaction of the materials of the paved road over the finished subgrade.

It should be considered that this improvement is made for the construction phase, since for the operation phase, the access road will be composed of a flexible pavement structure.

The initial activities for road construction are: clearing and cleaning, demolition and removal, excavation of the grading. These activities have already been described previously applied to the preparation of the land. Next, the remaining activities of the construction process for the access road are described.

- **Subgrade**



The preparation of the ground that will make the function of the subgrade, consists in a series of previous operations, whose execution is necessary and important to cement the placement of the paved road on the subgrade.

- Scarification and homogenization of the subgrade: The procedure consists of breaking up the surface of the soil along and across what will be the roadway at a specified depth, allowing it to acquire a loose condition. This procedure is done with a crawler tractor or by scarifiers or disc harrows.



Photo Num. 3.4. Scarification of the surface of the subgrade
Source: PIO SAS, September 2015.

- Moisture of subgrade soil: After scarification and homogenization of the material, if the soil was very dry according to the specified moisture of the material has to compact, it can be moistened by traditional irrigation systems to bring it to a condition of $\pm 2\%$, with respect to the optimum

	ENVIRONMENTAL LICENSE MODIFICATION FOR THE CONSTRUCTION AND OPERATION PROJECT OF A PORT TERMINAL OF SOLID BULK CARGOES IN THE MUNICIPALITY OF TURBO	
	PROJECT DESCRIPTION	Page 52 of 165
	GAT-391-15-CA-AM-PIO-01	Revision:

humidity of compaction, obtained in the laboratory by means of the proctor test.





Photo Num. 3.5. Moisture of subgrade material when it is very dry
Source: PIO SAS, September 2015.

- Subsurface soil aeration: If the natural humidity is greater than optimum, the soil should be aerated by stirring it from one side to the other by means of a motor grader or by compacting and scarifying the soil in several passes, until it is brought to a condition of $\pm 2\%$ of the optimum compaction humidity, according to the specifications of the proctor test.



Photo Num. 3.6. Aeration of subgrade material when it has excess moisture
Source: PIO SAS, September 2015.



	ENVIRONMENTAL LICENSE MODIFICATION FOR THE CONSTRUCTION AND OPERATION PROJECT OF A PORT TERMINAL OF SOLID BULK CARGOES IN THE MUNICIPALITY OF TURBO	 aqua & terra
	PROJECT DESCRIPTION	Page 53 of 165
	GAT-391-15-CA-AM-PIO-01	Revision:

- **Compaction of the subgrade:** When the compaction operation is carried out, after leveling with the motor grader up to the required height of the subgrade layer, by means of conventional earthmoving techniques, a compaction is carried out with a roller compactor kickstand, and / or vibratory roller depending on the type of material, which is looking for a density that meets the proctor. To complete this operation, it must comply with the verification of the quality of the material that has been controlled by the laboratory and the levels that must be controlled by the topography. The finished surface of the subgrade section should not show deformations or ups and downs, which should be corrected if they exist.

- **Road Surfacing**

This work consists in the supply, transport, placement and compaction of the materials of the finished subgrade, in accordance with the specifications, alignments, slopes and dimensions indicated in the project plans and the instructions of the Supervisor.

- **Preparation of the existing surface:** The road surfacing material will not be unloaded until it is verified that the surface on which it is to be supported has the appropriate density and the dimensions indicated in the plans or defined by the Controller. All irregularities that exceed the tolerances admitted in the respective specification must be corrected in accordance with what is established in it.
- **Transport and placement of the material:** The material is transported and placed on the surface of the subgrade avoiding its segregation, or causing damage or contamination on the existing surface.
- **Extension, mixing and shaping of the material:** The material will be spread with a moisture content $\pm 2\%$ with respect to the optimum humidity, in a necessary thickness so that after being compacted, it has the design thickness. The spreading should be done with the appropriate equipment, either with a finisher or a motor grader to produce a layer of uniform thickness over the required width, according to the cross sections shown in the drawings. In case it is necessary to moisten or aerate the material to achieve compaction moisture, the Builder will use the appropriate and approved equipment, so as not to damage the underlying layer and leave a uniform moisture in the material.
- **Compaction of the material layer:** Once the material has the proper

	ENVIRONMENTAL LICENSE MODIFICATION FOR THE CONSTRUCTION AND OPERATION PROJECT OF A PORT TERMINAL OF SOLID BULK CARGOES IN THE MUNICIPALITY OF TURBO	
	PROJECT DESCRIPTION	Page 54 of 165
	GAT-391-15-CA-AM-PIO-01	Revision:

humidity and is properly formed, it will be compacted by means of mechanical compactors such as smooth rollers, rollers with pneumatic wheels or with other equipment approved for compaction, which produces the results required by the technical specifications of construction.

The compaction should progress gradually, on the tangents, from the edges towards the center and in the curves from the inner edge to the outside, parallel to the axis of the road and uniformly overlapping half the width of the previous pass. The procedure will be continued alternately until achieving a density that complies with the proctor, according to the specification, throughout the thickness of the layer.

Finally, after completing the compaction, transit can be enable.



All the materials of the pavement structure, their conditions of receipt are required by the guidelines established in the INVIAS standards in their latest version.

3.2.3.2.10 Bridge construction process

The length of the bridge has been dimensioned to avoid the intervention of the channel, so that the abutments of the bridge on each of the banks have been located in such a way that its construction is made on land.



Figure Num. 3.25. DELMAG hammer and crane

	ENVIRONMENTAL LICENSE MODIFICATION FOR THE CONSTRUCTION AND OPERATION PROJECT OF A PORT TERMINAL OF SOLID BULK CARGOES IN THE MUNICIPALITY OF TURBO	
	PROJECT DESCRIPTION	Page 55 of 165
	GAT-391-15-CA-AM-PIO-01	Revision:

Source: DC-PORT, November 2014.⁷

Due to the arrangement of the piles in each footboard of the bridge, these must be located with a template and on it a guide is supported that allows the correct location and placement of the pile.

Pile placement will be done with the crane of the piloting equipment, later, with the same crane, the hammer will be placed on the head and the pile will be driven; the crane will hold the hammer during the whole driving so that it does not work freely: The pile will slide until reaching the penetration due to its own weight. At this point additional penetration of the pile, generated by the own weight plus the weight of the pile driver, will be allowed.

After verifying and approving the installation tolerances and pile-pile alignment made by the surveying commission that define the position of the pile, the hammer is turned on and the pile is driven to the required height. The pile is suspended when the head of the pile reaches the level design or when the pile presents rejection to the pile.

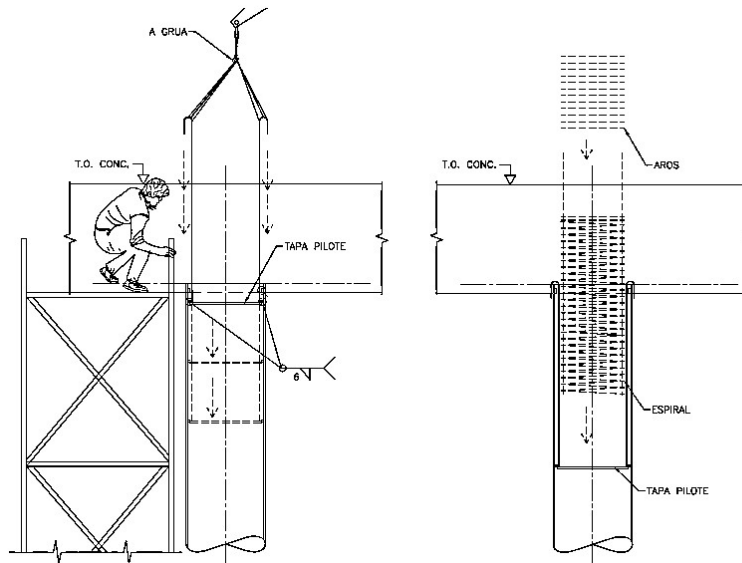



Figure Num. 3.26. Reinforcement installation inside the pile
Source: DC-PORT, November 2014.

⁷ DC-PORT, Conceptual report of the bridge over the river León, November 28, 2014.

	ENVIRONMENTAL LICENSE MODIFICATION FOR THE CONSTRUCTION AND OPERATION PROJECT OF A PORT TERMINAL OF SOLID BULK CARGOES IN THE MUNICIPALITY OF TURBO	
	PROJECT DESCRIPTION	Page 56 of 165
	GAT-391-15-CA-AM-PIO-01	Revision:

After the decapitation of the piles at their final elevation, the reinforcement steel basket is lifted by means of the crane to its final position inside the pile and the concrete is melted at the head of the pile. The reinforcing steel that is installed in the head of the pile and that develops inside the concrete mooring head, allows a connection that joins the two materials forming a structural node.

In the same way the concrete is allowed to enter inside a portion of the pile, so that a plug is formed that by friction of the concrete with the walls of the pile a structural core is formed that allows to transmit contact efforts and the development of the bars longitudinal of the steel basket inside the pile.

The transport of the concrete will be done with a pump and pipe and the placement may be direct unload, bucket-bucket or pump-pipe, depending on the conditions of access to the element.

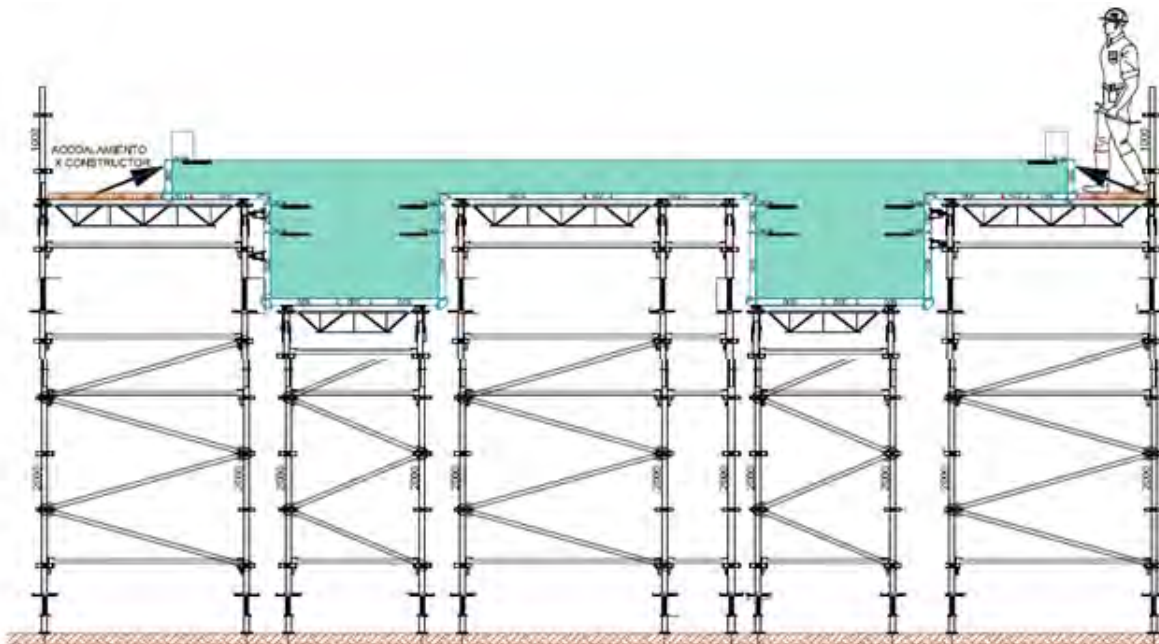



Figure Num. 3.27. Formwork elevation for cast
Source: DC-PORT, November 2014.

This activity will be developed for the emptying of the concrete of the abutments, corresponding to the heads that join the piles. Prior to the start of the work, the location and leveling of the form will be verified with the Topography commission.

The formwork consists of a metallic framework supported from the ground level to the lower level of the concrete, allowing the installation of the board that will support the emptying in the dimensions of the planes and the perimeter walkways for the

	ENVIRONMENTAL LICENSE MODIFICATION FOR THE CONSTRUCTION AND OPERATION PROJECT OF A PORT TERMINAL OF SOLID BULK CARGOES IN THE MUNICIPALITY OF TURBO	
	PROJECT DESCRIPTION	Page 57 of 165
	GAT-391-15-CA-AM-PIO-01	Revision:

transfer of workers and materials, ensuring that it is well leveled, leaded and that guarantee the good finishing of the concrete, has not displacements and guarantee the coating of the reinforcement steel.

Reinforcement can be carried out on the site, respecting the positions and distances established in the plans. Once it is guaranteed that the surface is clean, the reinforcement and form properly located, we proceed to the installation of the lateral formwork to shape the element and proceed with the emptying of the concrete.

The concrete transportation will be done with a pump and pipe and the placement may be direct unload, bucket-bucket or pump-pipe, depending on the conditions of access to the element.

The concrete will be emptied and vibrated to ensure that it remains in a homogeneous form as well as to avoid the "tingling" in any of its faces.

When the concrete has set, it will proceed to remove the form "desencofre" avoiding damaging the edges of the elements and making the required protection that guarantees a good finish.

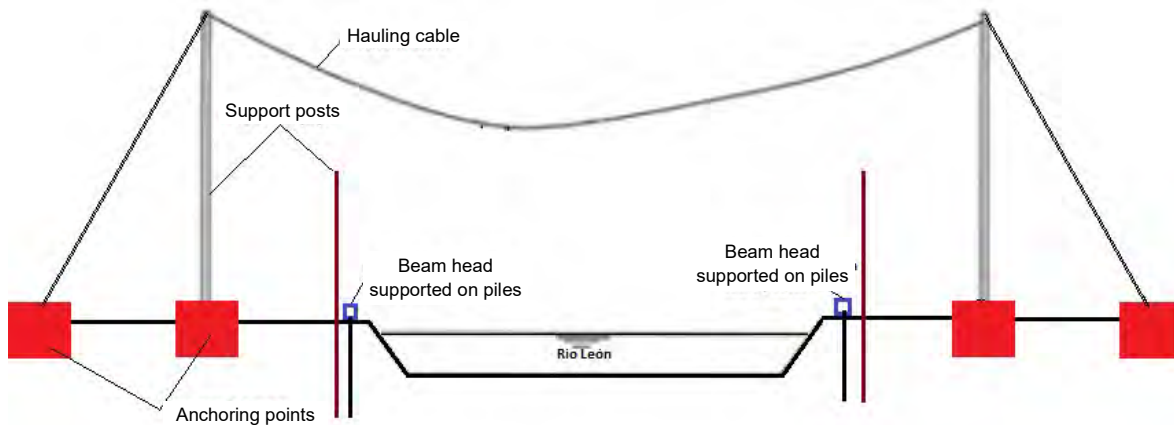



Figure Num. 3.28. Longitudinal elevation support structure and arc starting
Source: DC-PORT, November 2014.

Due to environmental restrictions, which prevent bridge supports invading the course of The León River, as during its construction, this proposal has been located far to the banks of the River and external to the location of the foundation of the bridge.

Parallel to the construction of the foundation system of the bridge, on both banks of The León River, the construction of the provisional support system that will allow launching the prefabricated metal arches will be carried out.

	ENVIRONMENTAL LICENSE MODIFICATION FOR THE CONSTRUCTION AND OPERATION PROJECT OF A PORT TERMINAL OF SOLID BULK CARGOES IN THE MUNICIPALITY OF TURBO	
	PROJECT DESCRIPTION	Page 58 of 165
	GAT-391-15-CA-AM-PIO-01	Revision:

During the construction of the foundation of the bridge, the constraint anchor will be built to support the main support pole and the cables that will maintain the hauling cable that transports the sections of the arch to its final location. These buried structures will be dimensioned so that their own inertia serves as a counterweight during the construction of the arches.

Closer to the foundation of the bridge will have a support post that will be the guide for the positioning of the cables in a fan, giving the separation and angle of the cables.

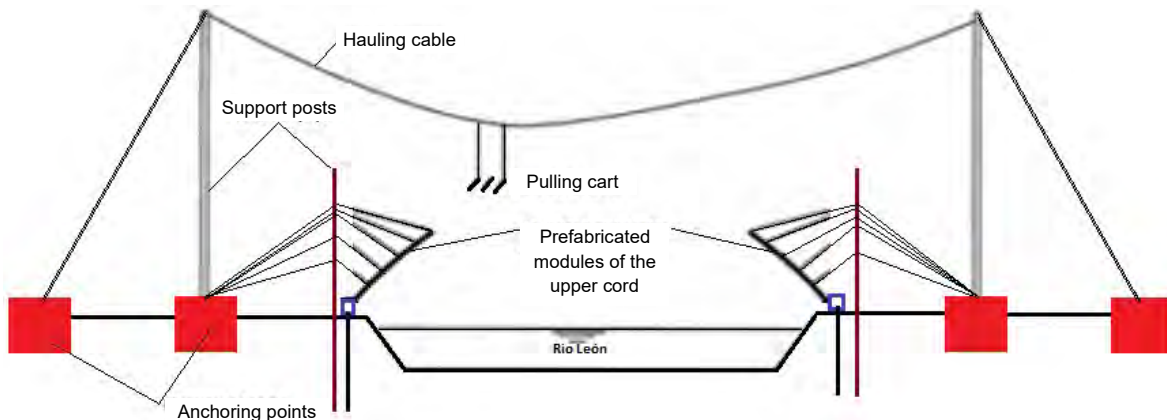



Figure Num. 3.29. Longitudinal elevation assembly of elements that make up the arch
Source: DC-PORT, November 2014.

By means of temporary braces, which will keep the segment of the upper cord of the arch in position, the cantilever advances will be made, maintaining the equilibrium of the system through the tethers and their retention in the definitive position within the structure. The start of the overhangs will be made from the definitive foundation of the Bridge.

The prefabricated modules of the arch, will be transported from the ground by an independent system of mobile hauling cable that at its ends has a winching system by winch and with a trolley suspended on the cable, will allow to raise and transport the modules on The León Riiver to position them and support them in the previous module and proceed again to their provisional tethering.

During the construction of the arch steel bridge, the following elements will be prefabricated to be installed by this method:

- Upper Arc Cord (Rigidizers and Connections)
- Windbreakers and braces

	ENVIRONMENTAL LICENSE MODIFICATION FOR THE CONSTRUCTION AND OPERATION PROJECT OF A PORT TERMINAL OF SOLID BULK CARGOES IN THE MUNICIPALITY OF TURBO	
	PROJECT DESCRIPTION	Page 59 of 165
	GAT-391-15-CA-AM-PIO-01	Revision:

- Plates (Connection Beam - Arc)
- Kingposts
- Longitudinal beams
- Stiffening beams
- Lower transversal beams
- Bottom trusses
- Cutting connectors

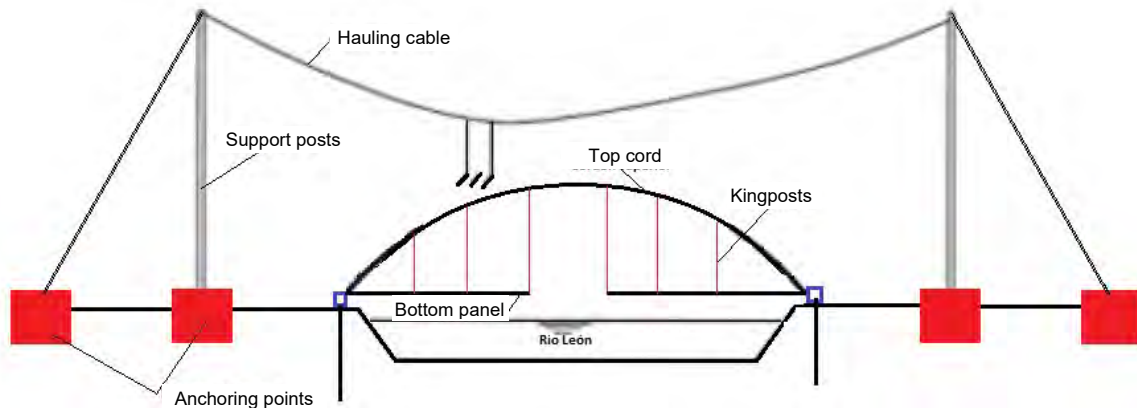



Figure Num. 3.30. Longitudinal elevation assembly of kingposts and lower board
Source: DC-PORT, November de 2014.

Once the assembly of the upper cord of the arch has been completed and its windshields installed, which avoid local bellows of the elements during the occurrence of a strong wind, the provisional cables are removed and their support post.

The rest of the construction of the bridge is continued with the mobile hauling cable with the suspended trolley. It continues with the installation of the set of the kingposts and the lower cord section, in such a way that the beam section is suspended by the 2 kingposts at their ends and that allows their coupling with the constructed arch.

Once all the elements of the arch are installed, the bracing beams are installed, and prefabricated concrete plates are placed on the lower cord of the bridge, covering

	ENVIRONMENTAL LICENSE MODIFICATION FOR THE CONSTRUCTION AND OPERATION PROJECT OF A PORT TERMINAL OF SOLID BULK CARGOES IN THE MUNICIPALITY OF TURBO	
	PROJECT DESCRIPTION	Page 60 of 165
	GAT-391-15-CA-AM-PIO-01	Revision:

the entire surface and then the concrete will be fused at its final level, eliminating jolts between plates and giving the slope of the pumping of the rolling layer. Finally the constraint anchors, the support posts and the hauling cable are removed and demolished.⁸

3.2.3.2.11 Heavy machinery maintenance workshops

The projection of work machinery in the area will be contracted outsourcing type, where this contractor will be responsible for the operation and maintenance of equipment. The area of routine maintenance, would be relocating according to the evolution of the work and will only be for cases of minor maintenance. For heavy maintenance conditions, the outsourcing will assume full responsibility for executing this activity in a workshop suitable for this function outside the onshore terminal area.

3.2.4 Port facilities

3.2.4.1 Description of Onshore Terminal Facilities

- **Entry portal**

The Entrance Portal facilities to the Customs Zone integrate six (6) entrance lanes and six (6) exit lanes. In each direction, the following distribution is established:

- One (1) lane for bulk trucks.
- Two (2) truck lanes with containers.
- Two (2) truck lanes with perishable fruits.
- One (1) lane for vehicles with extra dimensions.



Between the lanes of the same direction, a separating platform is designed in concrete of width 2.00 m. However, in the central bay that has an entrance lane on one side and an exit lane on the other, the central separator is 7.00 m.

The system will have 3 entry scales and 3 exit scales, which will guarantee that all the vehicles that deliver and remove cargo are weighed in compliance with the regulations.

The separating platforms house:

- Control gates.

⁸ DC-PORT, Conceptual report of the bridge over the river León, November 28, 2014.

	ENVIRONMENTAL LICENSE MODIFICATION FOR THE CONSTRUCTION AND OPERATION PROJECT OF A PORT TERMINAL OF SOLID BULK CARGOES IN THE MUNICIPALITY OF TURBO	
	PROJECT DESCRIPTION	Page 61 of 165
	GAT-391-15-CA-AM-PIO-01	Revision:

- Digital readers (Biometric Control).
- Structural support columns for the roof.
- Automatic vehicle barriers.
- Defenses in the event of vehicle crashes.
- CCTV cameras.
- Traffic lights.
- **Vehicle yard**

The vehicle yard of a dock is intended for parking, but mainly the vehicles that come from import. However, in this area an enclosure will be made in order to separate the parking area from the import vehicles. Likewise, the vehicle yard must have the optical character recognition (OCR) system and must be synchronized with the port recognition network. Phase 1 will have the option to park 2650 parking spaces. For the second phase will count 1140 parking lots.

- **Container washing warehouse**

The container washing bay in the first phase will have a cleaning effectiveness of 286 TEUs per day, stacked in columns of 5 containers, it is expected to receive a total of 100,000 refrigerated containers per year, which must have high quality standards, taking into account in mind that the import will be a perishable product as is the banana.



- **Repair and training warehouse**

This warehouse will have a repair area of 72 TEUs per day, taking into account that 25% of the containers that are disposed in the port must be repaired and adjusted in order to be transported.

- **Pre-Trip Inspection**

It refers to an inspection before the trip. However, the port concept is a mechanical revision that must be made to all containers that enter or leave the port. In this area, the status of the doors, screens and hooks is checked, checking that they do not show structural faults or holes. In the case of refrigerated containers, it is verified how the engine and electrical connections are, among others.

- **Refrigerated container area**

	ENVIRONMENTAL LICENSE MODIFICATION FOR THE CONSTRUCTION AND OPERATION PROJECT OF A PORT TERMINAL OF SOLID BULK CARGOES IN THE MUNICIPALITY OF TURBO	
	PROJECT DESCRIPTION	Page 62 of 165
	GAT-391-15-CA-AM-PIO-01	Revision:

The port will have in its first phase a storage of racks of 6 levels of containers in rows of 6, arranged in such a way so that the RTG and an operator verify its functionality constantly and its operation both in exit and entry. For the second phase there will be a patio for empty refrigerated containers or 2400 TEUS. Including, a storage area that will have their respective RACKS. In case the demand for containers cannot be covered by the design, there will be some POWER PACKS containers which are containers adapted as electric stations to supply energy constantly.

- **Full container area**

Full containers are referred to as all cargo that is disposed inside dry or traditional containers, that is, containers that are not refrigerated. Transporting loose or tied cargo inside a container for protection of the environment.

These containers can transport vehicles, infrastructure, wood, etc. The total construction of the same will be done in the first phase. It will have machinery such as RTG, Reach Stacker, and vacuum lifts for loading and unloading them.



- **Consolidation and deconsolidation warehouses**

Consolidation and deconsolidation warehouses are an area in which merchandise and / or product that is imported or exported is unloaded and loaded respectively. These areas allow to observe the quality of the merchandise, detailing that there is no damage produced in the trip or in some occasions in the same unloading process.

There will be a closed warehouse in the first and second phase. It will have entrances and exit of trucks for the loading and unloading of containers on its longest side. Likewise, the warehouse will be closed so that they are not affected by the environment. The following will be its areas of operation:

- Customer service office
- Resting area
- Records
- Storage Director
- Storage Supervisor

It will be a closed warehouse from structural masonry walls, with an entrance and exit parallel to the longest side of the warehouse. Each entry must be divided by columns, which must be separated according to the design dump truck, which will be 3.5m for handling equipment and tools, and will be supported on a mooring beam

	ENVIRONMENTAL LICENSE MODIFICATION FOR THE CONSTRUCTION AND OPERATION PROJECT OF A PORT TERMINAL OF SOLID BULK CARGOES IN THE MUNICIPALITY OF TURBO	
	PROJECT DESCRIPTION	Page 63 of 165
	GAT-391-15-CA-AM-PIO-01	Revision:

to support the product load and the teams themselves. The roof will be made by means of a triangular truss.

- **Perishable warehouse**

Warehouse designed for the conservation and quality of food, which will be hermetic and will have some engines for refrigeration that can preserve the properties of bananas and other perishable products (pineapples, grapes, apples, among others).



- **Bulk silos**

For the storage of solid bulks, there will be a vertical silos battery configuration area (26 phase I silos and 14 phase II silos, for a total of 40 silos). On average it is estimated to receive 30,000 t / boat, with an average of 28 boats per year, that is, 2 boats per month (See Figure Num. 3.31 y Table Num. 3.10).

Next, a table is presented in which the storage capacity and its respective phases of construction are detailed:

Table Num. 3.10. Bulk storage capacity

CAPACITY FOR WAREHOUSES GRAINS AND BEANS PUERTO BAHÍA COLOMBIA DE URABÁ			
WAREHOUSE GRAINS	PHASE-1	PHASE-2	PHASE-3
Capacity in flat silos Ø75'	5500	5500	
Number of silos Ø75'	8	4	
Capacity in flat silos Ø42'	1400	1400	
Number of silos Ø42'	8	2	
Temporary storage			25500
TOTAL TONS OF MAIZE STORAGE (750 Kg./m3) AT EACH PHASE	55200	24800	25500
CAKES WAREHOUSE	PHASE -1	PHASE -2	PHASE -3
Capacity in flat silos Ø54'	2540		
Number of silos Ø54'	4		
Capacity in flat silos Ø48'	1990	1990	

	ENVIRONMENTAL LICENSE MODIFICATION FOR THE CONSTRUCTION AND OPERATION PROJECT OF A PORT TERMINAL OF SOLID BULK CARGOES IN THE MUNICIPALITY OF TURBO	
	PROJECT DESCRIPTION	Page 64 of 165
	GAT-391-15-CA-AM-PIO-01	Revision:

CAPACITY FOR WAREHOUSES GRAINS AND BEANS PUERTO BAHÍA COLOMBIA DE URABÁ			
WAREHOUSE GRAINS	PHASE-1	PHASE-2	PHASE-3
Number of silos Ø48'	2	2	
Capacity in conical silos Ø36'	1000	1000	
Capacity in conical silos Ø36'	4	6	
Til-tup type cellar, for cakes or fertilizers, of 26.60 m. width x 51.40 m. of Longt. between centers			8150
Quantity of warehouses			1
TOTAL TONNES OF STORAGE OF CAKES IN EVERY PHASE (600 Kg./m3)	18.140	9.980	8.150
TOTAL ACCUMULATED AT THE END OF EACH PHASE	18.450	28.430	36.580



Source: Study of solid bulk unloading markets in Puerto Bahía Colombia de Urabá, Turbo, Urabá. Ediagro, September 2014.

The total capacity in the first storage phase will be 73,650 t. That is, it has the capacity to store 2 boats of 30,000 t. In addition, it provides 24% for more storage. Likewise, the second phase covers the demand established by a ship. And finally for future phases, it is expected to unload a ship in the shortest time possible by storing it in the receipt hopper that will have the capacity of 25,500 t⁹

The main loads of solid bulks are:

- Animal feed: 615,000 tones / year
- Wheat: 100.000 tones / year
- Corn: 45.000 tones / year
- Fertilizers: 31.000 tones / year

⁹ Ediagro, STUDY OF DISCHARGE MARKETS OF SOLID GRANELS IN PUERTO BAHÍA COLOMBIA, TURBO, URABA, September 2014.

	ENVIRONMENTAL LICENSE MODIFICATION FOR THE CONSTRUCTION AND OPERATION PROJECT OF A PORT TERMINAL OF SOLID BULK CARGOES IN THE MUNICIPALITY OF TURBO	
	PROJECT DESCRIPTION	Page 65 of 165
	GAT-391-15-CA-AM-PIO-01	Revision:

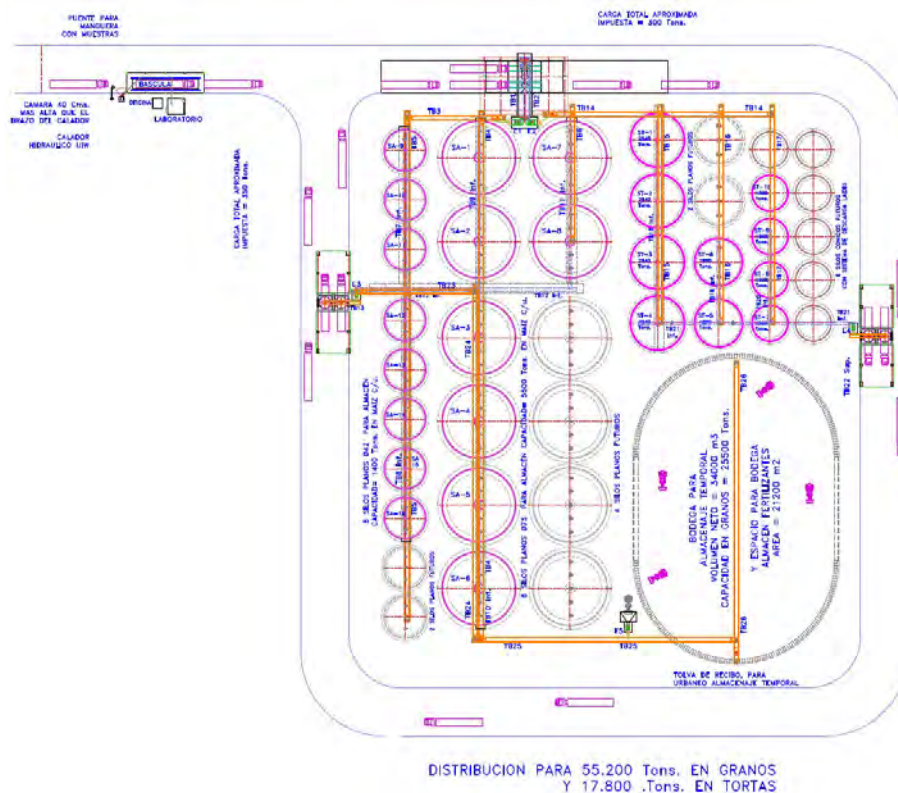



Figure Num. 3.31. Silos and grain storage warehouses Puerto Bahía Colombia de Urabá.
Source: EDIAGRO, 2014

- **Port facilities for handling liquid bulk other than hydrocarbons**

The port facilities for the handling of liquid bulk cargo will be specified for loading / unloading and storage of vegetable oil or palm and import of liquid banana industry.

This facility will have the storage capacity of 60,000 bls (9405 m³) corresponding to the load of a 5,000 dwt vessel. For the facility on land has been available 4 tanks of 15,000 bls, with dimensions of 16.7 m in diameter and 10.5 m in free height. For the containment of the tanks a 1.8 m wall has been designed in such a way that it contains 110% tank capacity plus a 10 cm free edge.

Additionally, this area this facility will have a dispatch system consisting of 5 pumps, four constant work and one backup, a control room and a quarter of foam, as part of the firefighting system of the port facility. This system is directly connected to the filling island of tank cars (see Figure Num. 3.32), with provision of 4 simultaneous loading station.

	ENVIRONMENTAL LICENSE MODIFICATION FOR THE CONSTRUCTION AND OPERATION PROJECT OF A PORT TERMINAL OF SOLID BULK CARGOES IN THE MUNICIPALITY OF TURBO	
	PROJECT DESCRIPTION	Page 66 of 165
	GAT-391-15-CA-AM-PIO-01	Revision:

Finally, there will be a transport system by repumping through a 10-inch diameter pipe for each of the tanks and it will be connected to the manifold or flow distributor towards the maritime dock.

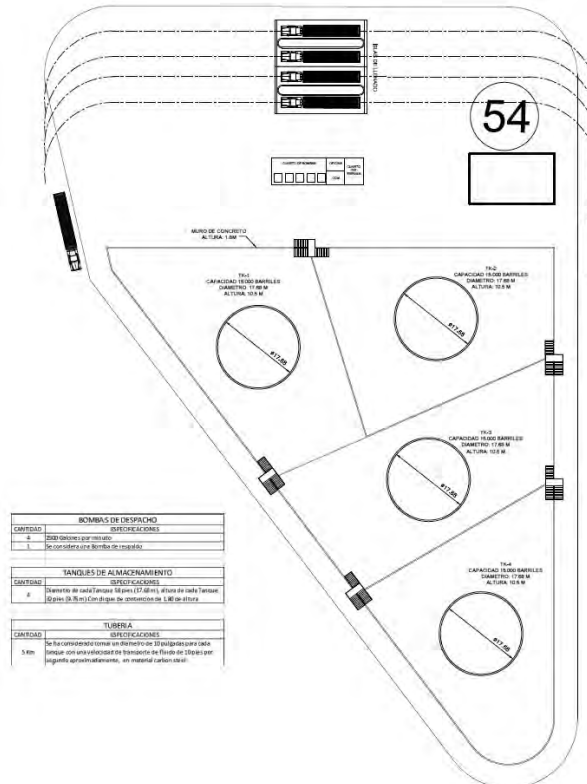



Figure Num. 3.32. Liquid bulk silos.
Source: PIO SAS, September 2015.

Fire system

The use of the shared tank installation and the fire network are projected, with hydrants connected at the crucial points of the infrastructure and more likely to be affected by such a risk.

According to Title J of the Earthquake Resistant Standard - 2010, and Colombian Technical Standards 1669 and 2301, criteria are specified for the fire protection system to be projected in the project. Likewise, all design and construction in the following phases of the project must adhere to these two standards, and apply the corresponding legislation.

Categorization

	ENVIRONMENTAL LICENSE MODIFICATION FOR THE CONSTRUCTION AND OPERATION PROJECT OF A PORT TERMINAL OF SOLID BULK CARGOES IN THE MUNICIPALITY OF TURBO	
	PROJECT DESCRIPTION	Page 67 of 165
	GAT-391-15-CA-AM-PIO-01	Revision:

According to paragraph J.3.3 of the NSR-10, it is established how the projected buildings belong to Category III, as buildings with low combustion capacity, being warehouses and industrial buildings that do not handle wood, paints, plastics, cotton, fuel or explosives of any kind. Within category F-2, with a fuel potential Cc <2000.

Flow of the fire system

According to Colombian Technical Standard NTC 1669, the fire system is categorized as a Class I System, "A system provided with 65 mm (2 1/2 inch) hose stations to supply water for use by firefighters and trained personnel. the handling of heavy jets for fire."

When a main network (horizontally) in the Class I system supplies three or more hose connections on any floor, as is the case of the conceptually projected network, where at the ground level there are 4 branches of pipeline the matrix of the system, the minimum flow for the main network (horizontally) of greater hydraulic demand will be 2840 L / min (750 gpm).

Hydrants

The buildings and storage areas must be protected by a system of fixed sockets for firefighters and fire extinguishing hoses designed in accordance with the latest version of the Code for the supply and distribution of water for extinguishing fires in buildings, NTC 1669, and with Code for the Installation of Vertical Piping Systems and Hoses, NFPA 14. The Table Num. 3.11 details the constructed areas that require the installation of hydrants in the onshore facilities.



Table Num. 3.11. Areas built onshore facilities that require hydrants

Use	Area (m ²)			
	Phase I	Phase II	Phase III	Total
ONSHORE FACILITIES				
Silos batteries	15.880	6.420	6.400	28.700
Warehouse zone	17.000	9.000	0	26.000
Common zones	52.700			52.700
Administration buildings and services	9.700	0	0	9.700
Electrical substations	1.600	0	0	1.600
TOTAL				118.700

Source: Conceptual engineering of integrated management of water resources in Puerto Bahía Colombia de Urabá, PIO SAS, October 2015.

Applying the criterion of item J.2.4.4 of the NSR-10, the number of hydrants is estimated as (118700/5000 m² = 23.74), that is, 24 hydrants. The flow of each hydrant must be 32 L/s.

Internal networks of sprinklers - diffusers

	ENVIRONMENTAL LICENSE MODIFICATION FOR THE CONSTRUCTION AND OPERATION PROJECT OF A PORT TERMINAL OF SOLID BULK CARGOES IN THE MUNICIPALITY OF TURBO	
	PROJECT DESCRIPTION	Page 68 of 165
	GAT-391-15-CA-AM-PIO-01	Revision:

Due to the fact that no buildings with more than three [3] floors are planned, it is not necessary to have an internal fire network installed in the project buildings. Buildings must be protected by a portable fire extinguisher system, designed in accordance with the latest version of the Portable Fire Extinguishers standard, NTC 2885 and the Portable Fire Extinguisher Standard, NFPA 10.

Minimum supply

The water supply must be capable of supplying the demand of the system established in item 3.5.2 for at least 30 minutes, the estimated time of arrival of firefighters. That means, that the minimum storage volume of the tank is related to the volume ($2840 * 30 = 85200$ L).

Pipe and accessories

The minimum nominal diameter for the main network and supply pipes, taking into account that the total accumulated flow is 750 gpm, and that the total distance of pipe from the furthest outlet is greater than 30.5, it must be 6 inches. The connection to the projected storage tank must have indicator type valves and check valves, approved and located near the aforementioned tank.

Valves must be installed to isolate each of the main networks without interrupting the supply to the other main networks from the same source of supply. Indicated type valves should be installed at the outlet of the main network to control branches that supply remote hose stations, in the locations detailed in the Figure Num. 3.33.



Storage

With the minimum storage volume of the tank defined as 300,000 L [300 m³] a rectangular geometry is established, with dimensions of 10m long, 10m wide, 3m high plus a free edge of 0.50m.

System against fire in the projected Dock

The fire protection system in the projected Dock will be executed by means of a pumping equipment that will extract seawater. The system for supplying the 4 underground hydrants at the dock will be composed of:

- Water injection point against fire.
- Distribution network composed of 200 mm PVC pipes, with flanged joints. These pipes will be hung to the underside of the slab of the dock with a transport capacity of approximately 1000 GPM and a maximum load loss of 10.00 m.c.a.

	ENVIRONMENTAL LICENSE MODIFICATION FOR THE CONSTRUCTION AND OPERATION PROJECT OF A PORT TERMINAL OF SOLID BULK CARGOES IN THE MUNICIPALITY OF TURBO	
	PROJECT DESCRIPTION	Page 69 of 165
	GAT-391-15-CA-AM-PIO-01	Revision:

- Underground hydrants, protected by a cast iron box and attached to the side of the slab of the dock.





Figure Num. 3.33. Location of valves for sectorization of the fire network, red arrow with blue

Source: Conceptual engineering of integrated management of water resources in Puerto Bahía Colombia de Urabá, PIO SAS, October 2015.

Fire system in the oil storage area of the food industry

Specifies the need to have at least two type K satellite extinguishers, which must be in accordance with the technical standards NTC 652, NTC 1916, NTC 2885 (NFPA-10).

Likewise, it is also planned to install a foam sprinkler system given the material to be stored; there will be a fixed system of water spray or foam, consisting basically of wet pipe, connected to a foam tank connected in turn to the supply for the fire network, in the case of foam sprinklers. The wet pipeline will be provided with specific spray nozzles equipped with thermal firing blister, both for foam unload and for its distribution on the surface to be protected. The pipes will have a slope of 12.00 mm

	ENVIRONMENTAL LICENSE MODIFICATION FOR THE CONSTRUCTION AND OPERATION PROJECT OF A PORT TERMINAL OF SOLID BULK CARGOES IN THE MUNICIPALITY OF TURBO	
	PROJECT DESCRIPTION	Page 70 of 165
	GAT-391-15-CA-AM-PIO-01	Revision:

/ m towards the control post to allow their drainage. For the design of the foam network, the provisions of Standard NFPA 11-A must be followed.

General description and characteristics of the foam concentrate: The low expansion foam extinguishing system is chosen, considering that it is the most suitable for the stored material. It will be an automatic system, since thermal sprinklers with wet pipes with foam injection will be used. The extinguishing agent will be the 3% AFFF foam concentrate. It is the most suitable for the stored material, since it is fuel with low water solubility. Its characteristics are the following: Density: 1.011 g / mL, pH: 7.5, Refractive index: 1.3640, Coefficient of extensibility: 5.8.



In fire accidents involving oils of vegetable or animal origin water should not be used since there would be explosions with the consequent splashing of oil that due to its high temperature would result in serious burns injuries to people present in the place and to the fire focus dispersion.

In order to improve the labor and environmental safety conditions of the area, basic elements must be available to prevent the spreading of a fuel or lubricant spill in the igniting state, as well as its infiltration into the subsoil. The runoff and fire situation can be stopped with gutters and containment barriers or dams around the spill, and then pick it up with some absorbent material such as sand that should be readily available.

The material collected must be handled as a hazardous waste, so it must be disposed of in an authorized place outside the fire containment area or buried in a waterproofed well, avoiding the possibility of contaminating water resources. Sand should be spread on the surface where the spill occurred, and wait a few minutes until the scattered material absorbs the ignition result. The sand that has absorbed the spilled product should be swept, or picked up with a shovel, and placed in a container with the indication of the content, where they will be kept until their later elimination, reason why it must have a storage of minimum 1 m³ of sand within the vicinity of what is protected by the dike, in a place that is easy to reach in case of emergency. It is necessary that the operator and the fire brigades wear protective gloves and a nitrile rubber face mask.¹⁰

- **Estimated Excavations**

¹⁰ Conceptual engineering of integrated water resources management in Puerto Bahía Colombia de Urabá, PIO SAS, October 2015

	ENVIRONMENTAL LICENSE MODIFICATION FOR THE CONSTRUCTION AND OPERATION PROJECT OF A PORT TERMINAL OF SOLID BULK CARGOES IN THE MUNICIPALITY OF TURBO	
	PROJECT DESCRIPTION	Page 71 of 165
	GAT-391-15-CA-AM-PIO-01	Revision:

Work of excavations on land are not contemplated, due to the concept of stabilization of the land and final finishing of the onshore terminal. There improvement of the land is contemplated without excavations, by stabilization by compaction, preload, columns of gravel, among others. The material of stripping of approximately 35,000 m³, will be arranged and compacted for use of jars along the right bank of the the Leon River.

- **Buildings**

The main buildings that are in the terminal on land are:



- Surveillance and control building
- Administration building
- Dining building for warehouse areas
- Lodging area of the anti-narcotics police
- Inspection warehouse for perishable exports
- Import inspection warehouse
- Maintenance workshop
- Replacements warehouse
- Fire building
- Nursing
- Gas station
- Fuel storage and office.

3.2.4.2 Infrastructure associated with the project

3.2.4.2.1 Camps

The conception of the project proposes the installation of portable units such as the use of offices and necessary facilities during the construction of the port. Because of food handling and accommodation those will be developed outside the onshore terminal.

3.2.4.2.2 Collection sites

	ENVIRONMENTAL LICENSE MODIFICATION FOR THE CONSTRUCTION AND OPERATION PROJECT OF A PORT TERMINAL OF SOLID BULK CARGOES IN THE MUNICIPALITY OF TURBO	
	PROJECT DESCRIPTION	Page 72 of 165
	GAT-391-15-CA-AM-PIO-01	Revision:

It will define a collection area of construction materials, prefabricated and assembly of infrastructure. This area will consist of approximately 4 ha. The main storage materials are:



- Gravel
- Grit
- Sand
- Aggregates
- Geotextiles
- Steel (Reinforcing steel, structural elements and steel sheet)
- Excavated material (if reused)
- Prefabricated concrete
- Prefabricated piles

3.2.4.2.3 Sources of materials

The main source of material is Designs, Aggregates and Constructions of Urabá S.A.S (D.A & C de Urabá S.A.S). Which has two mining titles located in the municipality of Carepa and Turbo, located approximately 15 and 25 km from the construction development of Puerto Bahía Colombia de Urabá.

The information from these material sources is summarized below:

1. Mine located in the Municipality of Carepa:
 - Type of Mine: Alluvial (boulder) – Carepa river
 - Area: 1.410,93 Hectares
 - Mining Concession Contract: 7693 of December 9, 2008
 - National Mining Registry: HJBL - December 7, 29, 2009
 - Legality: Plan of Works and Works (P.T.O) Approved by the Government of Antioquia - Secretary of Mines - Resolution No. 067459 of December 7, 2012
 - Environmental license granted by CORPOURABA, Resolution No TRD 200-03-20-02-0787-2012 of 05/07/2012

	ENVIRONMENTAL LICENSE MODIFICATION FOR THE CONSTRUCTION AND OPERATION PROJECT OF A PORT TERMINAL OF SOLID BULK CARGOES IN THE MUNICIPALITY OF TURBO	
	PROJECT DESCRIPTION	Page 73 of 165
	GAT-391-15-CA-AM-PIO-01	Revision:

- Diagnosis and Valuation of the Archaeological Heritage
- Certificates: Ministry of the Interior and Justice (Indigenous and / or Black Communities) and UNAT (Indigenous and Afro-Colombian Communities)

2. Mine located in the Municipality of Turbo:

- Jurisdiction: Currulao – la Galleta Sector
- Mine type: Alluvial (boulder) –Currulao River
- Area: 1.324,60 hectares
- Mining Concession Contract: 7697 of November 13, 2007
- National Mining Registry: HHVN - December 2, 18, 2007
- Legality: Works and Works Plan (P.T.O) and Environmental Impact Study (E.I.A)

The main materials available in the sources of materials are:



Table Num. 3.12. Available materials

SANDS	WITHOUT PROCESSING	PROCESADOS
Sand for Concrete - washed	Stone for Gabion	Crused $\frac{3}{4}$ " - washed
Pasting Sand (mortar) - washed	Pea gravek	Crused 1 $\frac{1}{2}$ " - washed
Plastering sand - washed	Grit	Crused 1" - washed
	Rockfill	Subase processed
	Raw material (filled and road surfacing)	Granular Base

Source: Aqua & Terra Consultores Asociados, 2015.

3.2.4.2.4 Process plants

As part of the construction process it has been defined to have a concrete and prefabricated plant in situ, which will have an approximate area of 7 ha. This plant will be located on a stabilized land. The soil that is going to stabilize previously for the collection of materials and for the assembly of the necessary infrastructure for the production of piles has an area of 4 ha. Subsequently, an area of 7 ha will be stabilized for the assembly of the concrete and prefabricated factory.

	ENVIRONMENTAL LICENSE MODIFICATION FOR THE CONSTRUCTION AND OPERATION PROJECT OF A PORT TERMINAL OF SOLID BULK CARGOES IN THE MUNICIPALITY OF TURBO	
	PROJECT DESCRIPTION	Page 74 of 165
	GAT-391-15-CA-AM-PIO-01	Revision:

These process plants will have as main objective the reuse of industrial wastewater that comes from concrete mixers, vehicle washing and maintenance of the concrete preparation area.

The system is basically composed of a settler with slope bottom that acts as a settler of coarse material (sand and gravel). Under a series conduction system, it will connect to a battery of settlers to remove the finest material and solids in suspension. This recycled water will be pumped to the storage tank where it will be connected again to the industrial production process.

3.2.4.2.5 Energy supply infrastructure

Initially, Empresas Públicas de Medellín will provide a transformation bay 115 / 34.5 kV, which will feed the main substation of the port (SE1) and from this four substations will be derived more distributed in the port in such a way that it is possible to comply with the normative parameters for this type of facilities. This substation will have two outputs in 34.5 kV, one of them will feed the substation dedicated to the loads located in the dock (SE5) and the other will supply the substations (SE1a SE2 SE3 and SE4) for the loads located in the onshore terminal.

The distribution of power in the port will be done at a voltage level of 13.2 kV, making the corresponding transformations at low voltage, in each substation. For the low voltage network and as established by NTC 2050 to feeders and branch circuits, the nominal voltages of 120, 120/240, 208Y / 120, 220Y / 127, 240, 347, 440Y / 254 must be applied, 480Y / 277, 480, 600Y / 347 and 600 V¹¹.



The distribution of areas for the substations is related below:

Table Num. 3.13. Substation areas.

Substation	Area
1	391.6
2	5.2
3	48.04
4	11.28
5	556.6

3.2.4.2.6 Access path

¹¹ General Document Electromechanical Conceptual Engineering, IP242-SE-SPA-GEN-IN-910, 2015.

	ENVIRONMENTAL LICENSE MODIFICATION FOR THE CONSTRUCTION AND OPERATION PROJECT OF A PORT TERMINAL OF SOLID BULK CARGOES IN THE MUNICIPALITY OF TURBO	
	PROJECT DESCRIPTION	Page 75 of 165
	GAT-391-15-CA-AM-PIO-01	Revision:

The design of the access road between Nueva Colonia and Puerto Bahía Colombia de Urabá, designed with a length of 2.46 km and a minimum width of 10.3 m, comprised of 2 lanes of 3.65 m and berms of 1.50 m. The structure of the paved road of 12 cm MDC-2, asphalt base and granular base. The weekly daily traffic projection (TPDS) for 2019 is 2750 trucks and in 2040 a total of 5092 trucks.¹²

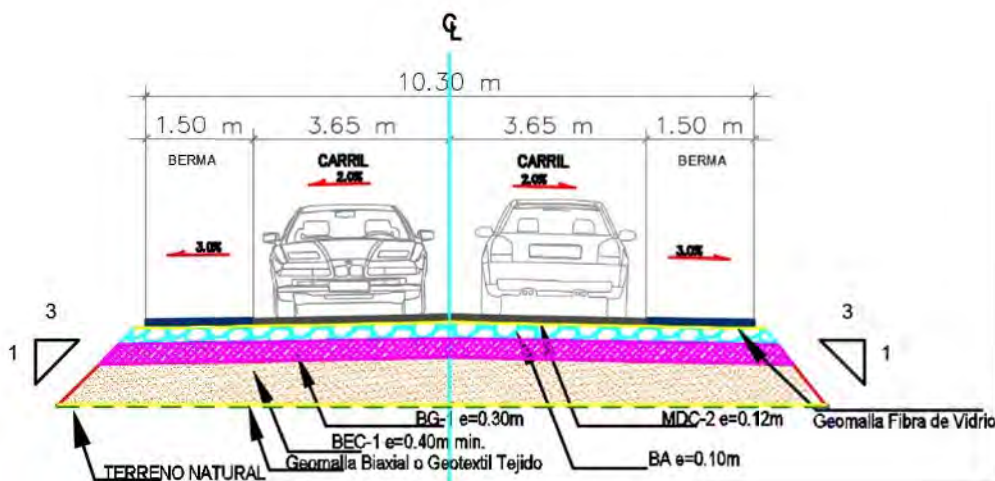

Figure Num. 3.34. Typical section of road structure from Nueva Colonia to Puerto Bahía Colombia de Urabá.



Source: Edifica, Geotechnical study, 2015.

In order to facilitate the construction process of the works, the improvement of the existing road (from the new colony to the port) must be made over a length of approximately 1.57 km and a bench of 10.3 m, as shown in Figure Num. 3.34. This improvement must take into account the specifications for the transit of freight vehicles and consists of the supply, transport, placement and compaction of the materials of the substantiated over the finished subgrade.

It should be considered that this improvement will be made for the construction phase, since for the operation phase, the access road will be composed of a flexible pavement structure.

This road consists of two (2) culverts projected in the design of the track on K1 + 000 and K2 + 000.

¹² Vial Group, Basic and Detail Engineering, Purchasing and Supply of Materials, Construction, Assembly and Commissioning of the Works Required for Phase 1 of the Puerto Bahía Port of Colombia Urabá Port Terminal. Transit Study, Department of Antioquia, June 2015.

	ENVIRONMENTAL LICENSE MODIFICATION FOR THE CONSTRUCTION AND OPERATION PROJECT OF A PORT TERMINAL OF SOLID BULK CARGOES IN THE MUNICIPALITY OF TURBO	
	PROJECT DESCRIPTION	Page 76 of 165
	GAT-391-15-CA-AM-PIO-01	Revision:

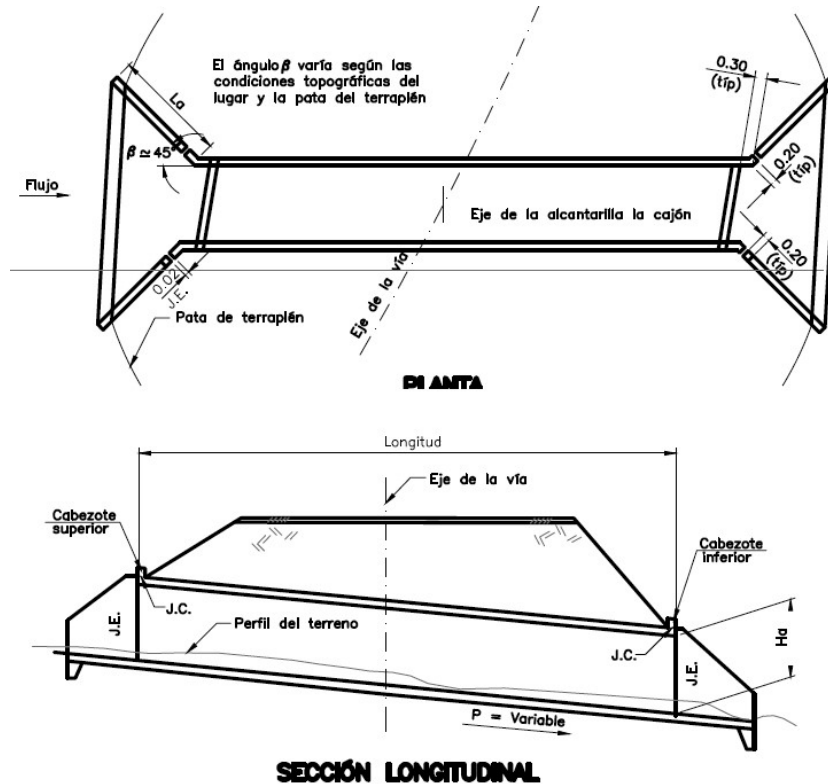

Figure Num. 3.35. Typical section of box culvert Puerto Bahía Colombia de Urabá.

Source: Aqua & Terra Consultores Asociados SAS, September 2015.

3.2.4.3 Infrastructure and services intercepted by the project

Considering the fact that there are no public services in the onshore terminal area, there will be no impact on existing networks and, therefore, carry out relocation, relocation and protection activities.



3.2.5 Project inputs

3.2.5.1 Volumes of Building Materials

The main volumes associated with the construction of Puerto Bahía Colombia de Urabá are:

Table Num. 3.14. Concrete volumes for onshore terminal.

Onshore Terminal

	ENVIRONMENTAL LICENSE MODIFICATION FOR THE CONSTRUCTION AND OPERATION PROJECT OF A PORT TERMINAL OF SOLID BULK CARGOES IN THE MUNICIPALITY OF TURBO	
	PROJECT DESCRIPTION	Page 77 of 165
	GAT-391-15-CA-AM-PIO-01	Revision:

Type of concrete	Volume (m ³)
CONVENTIONAL STRUCTURES	25000
Blocks and Others	12574.8
Cobblestones	1600
Enclosure	1125
CONCRETE PLATES	15000
TOTALS	55299.8

Source: PIO SAS, September 2015.

Table Num. 3.15. Volumes of dock and viaduct materials.



Dock and Viaduct		
Materials	Unit	Total
TOTAL PILE WEIGHT	TN	74341.0
PREFAB F´C 28 Mpa LOW PERM. BEAMS	M3	10054.4
PREFAB F´c 28 Mpa LOW PERM PLATES	M3	25690.9
IN PLACE F´c 28 Mpa LOW PERM	M3	57675.1
IN PLACE PILE CAPS F´c 28.5 Mpa	M3	29597.7
REINFORCING STEEL Fy 420 Mpa FIGURED	TN	14448.3
ELECTROSOLDED MESHES Fy 420 Mpa	TN	1810.6
PRE-STRENGTH Fy 770 Mpa o SUP	TN	1492.5
METALLIC INCUSES	TN	137.1
METALLIC STRUCTURE EPOXY PINT	TN	858.0
TEMPORARY STRUCTURE CANTITRavelER	TN	169.0

Source: PIO SAS, September 2015.

3.2.5.2 Leftover materials

In the process of construction of Puerto Bahía Colombia de Urabá, no disposal of material has been contemplated, taking into account the processes described above. However, in case of requiring the disposal of surplus material, it will be disposed in the dump closest to the construction work and the builder will be responsible for its management and adequate disposal.

3.2.6 Operation phase

	ENVIRONMENTAL LICENSE MODIFICATION FOR THE CONSTRUCTION AND OPERATION PROJECT OF A PORT TERMINAL OF SOLID BULK CARGOES IN THE MUNICIPALITY OF TURBO	
	PROJECT DESCRIPTION	Page 78 of 165
	GAT-391-15-CA-AM-PIO-01	Revision:

3.2.6.1 Port Operations Description

The Multipurpose Terminal of Puerto Bahía Colombia de Urabá will be designed with a specialized berth for containers in dock 1A and three multipurpose berths in docks 1B, 1C and 1D to operate containers, solid bulk, palletised fruit, vehicles and cargo general, in the first phase. For phase 2 with the extension of the dock the berth configuration changes to 2A for containers and 2B for bulk.

- **Entourage Yards**

The Port Terminal will have a national transit system that will ensure that transport companies and their representatives can ship the vehicles for delivery to the terminal of the export cargo and pick up imported goods. The terminal will have an obstruction parking lot where the tractors with export cargo can wait for the exporters to carry out the procedures with the competent authorities to be able to enter the terminal the export goods, this parking will be a traffic buffer for both entering and leaving the maritime terminal.

- **Export operations of Banana, Plantain and exotic fruits**



Packing shed

The vehicles with bananas, banana and exotic fruits destined for export will arrive directly from the beneficiation plants in the farms to a large shed where the cross docking of the palletized banana and the palatization of banana and other exotic fruits that are exported will take place in loose boxes.

The cross docking zone will have 40 doors for the unloading of vehicles and 20 doors for the packing of containers or load of fruit palletized to vehicles; The zone of palatization of Bananas and other exotic fruits will have 7 doors to unload vehicles and 4 doors for the container packing or load of pallets to vehicles. The operation in this shed will be done with electric forklifts and pallet trucks. There will be a workshop close to the empty container yard where the preparation of refrigerated containers for the export of bananas, bananas and exotic fruits will be made.

Transfer and Loading of Refrigerated Containers

Refrigerated containers will be transferred from the packing shed to the refrigerated container yard, using terminal tractors, in the offshore platform, where the containers will be connected to a modern electric power supply system and to control the operation of the container, RTG will be available for the receipt / delivery and stacking of containers in the yards of the maritime terminal, then the transfer will be

	ENVIRONMENTAL LICENSE MODIFICATION FOR THE CONSTRUCTION AND OPERATION PROJECT OF A PORT TERMINAL OF SOLID BULK CARGOES IN THE MUNICIPALITY OF TURBO	
	PROJECT DESCRIPTION	Page 79 of 165
	GAT-391-15-CA-AM-PIO-01	Revision:

made from the stacking area of the RTGs to the side of the ships where by means of ship's gantry cranes STS will load the refrigerated containers and connect to the vessel's power supply system.

Transfer and Loading of Palletized Fruit on Refrigerated Ships

The transfer of banana, plantain and exotic fruits that are exported palletized between the consolidation shed to the side of the refrigerated vessel will be carried out using terminal tractors with chassis or pallet truck, next to the ship the vehicles will be unloaded with forklifts and will be loaded with the lifting means of the vessel, for the stowage of the pallets in the warehouse and between-deck space of the refrigerated vessel using pallet trucks and electric forklifts.

It is planned to work two (2) refrigerated vessels simultaneously and each vessel is planned to work three (3) services with cranes belonging to the ship. Each service will be assigned to the side of the ship two (2) diesel forklifts of 3.5 t. Each service on board the vessel is planned four (4) electric walking palletizer operator (pallet trucks). It is planned to operate the two refrigerated vessels twelve (12) diesel forklifts of 3.5 t and twenty-four (24) walking palletizer electric operator (pallet trucks). It is also possible to operate simultaneously three (3) refrigerated vessels with two (2) services per vessel.



- **Container Operation**

Operation of Container Ship Vessels

Operation loading / unloading container ships will be carried out with modern New Post Panamax Gantry Cranes and Liebherr Model LHM 550 Mobile Crane (see Photo Num. 3.7), the transfer between the side of the ship and the yard and vice versa, will be done with dock tractors and the receipt and delivery of containers in the yards will be done with RTG.

Receipt / Delivery of Containers

The receipt / delivery of containers with import and export goods to customers will be made in the yard of the maritime terminal, with the exception of the containers with imported merchandise profiled to be inspected by the ICA, INVIMA and DIAN authorities that will be transferred by the concessionaire to the terrestrial terminal where an inspection shed will be available, where the authorities can exercise their inspection functions, guaranteeing the agility and integrity of the merchandise. Containers with imported goods, which in the interest of the clients decide to carry out pre-inspection, may also be transferred by the concessionaire to this inspection

	ENVIRONMENTAL LICENSE MODIFICATION FOR THE CONSTRUCTION AND OPERATION PROJECT OF A PORT TERMINAL OF SOLID BULK CARGOES IN THE MUNICIPALITY OF TURBO	
	PROJECT DESCRIPTION	Page 80 of 165
	GAT-391-15-CA-AM-PIO-01	Revision:

shed to carry out the pre-inspection operation.

Containers with import goods that in the interests of the shipping company or the customer may be deconsolidated in the area of deconsolidation of containers that is in the terminal on land, the concessionaire will provide the service of transfer of the container, deconsolidation of the container, storage of the goods in a cellar with shelving and the dispatch of the merchandise according to the needs of the client and the delivery of the empty container to the shipping company.

The containers with import goods in customs transit DTA, will be loaded in the maritime terminal and the vehicle with the container will be transferred to the offices of the DIAN in the inspection shed to perform the procedures required by the DIAN.

Containers that arrive at the maritime terminal with export merchandise, before allowing entry to the maritime terminal will be submitted to the profiling of the anti-narcotics police, if the container is profiled for inspection the vehicle will enter the terminal and the container will be received with Reach stacker in the patio of the counter-narcotics inspection shed and subsequently these containers will be loaded on a terminal tractor to be subjected to physical or non-intrusive inspection according to the instructions of the anti-narcotics police, once the counter-narcotics inspection is completed the container will be transferred to the containers in the maritime terminal and will be ready to embark.

Fulfilling the requirements of the authorities, the marine terminal will have a Cut-Off for containers with export goods that must be at least 24 hours from the scheduled date and time of the arrival of the ship where its shipment is planned.



This terminal will have an operational software for containers, which will perform the planning of the ship, the yards, the receipt and delivery of containers, the operation in the consolidation / deconsolidation station and the electronic exchange of data with other terminal software.

Container Ship

The operation of a container ship is budgeted at berth 1A with three (3) Ship to Shore STS cranes. Each Ship to Shore STS crane¹³ will be assigned four (4) Terminal Tractors, for a total of twelve (12) tractors.



A Ship to Shore crane is planned for three (3) Rubber Tired Gantry Cranes (RTG), for a total of nine (9) Rubber Tired Gantry Cranes (RTG).

¹³ Technical Document / Technical Review Nautical Aspects Port Rotterdam Consultants, 2015.

	ENVIRONMENTAL LICENSE MODIFICATION FOR THE CONSTRUCTION AND OPERATION PROJECT OF A PORT TERMINAL OF SOLID BULK CARGOES IN THE MUNICIPALITY OF TURBO	 aqua & terra
	PROJECT DESCRIPTION	Page 81 of 165
	GAT-391-15-CA-AM-PIO-01	Revision: <input type="text"/>

For the operation of container ships that are docked in non-specialized docks (1B, 1C and 1D), one (1) super post panamax mobile harbor crane will be operated.

Next, it is presented by means of a flowchart, the operative description of containers.

	ENVIRONMENTAL LICENSE MODIFICATION FOR THE CONSTRUCTION AND OPERATION PROJECT OF A PORT TERMINAL OF SOLID BULK CARGOES IN THE MUNICIPALITY OF TURBO	
	PROJECT DESCRIPTION	Page 82 of 165
	GAT-391-15-CA-AM-PIO-01	Revision:

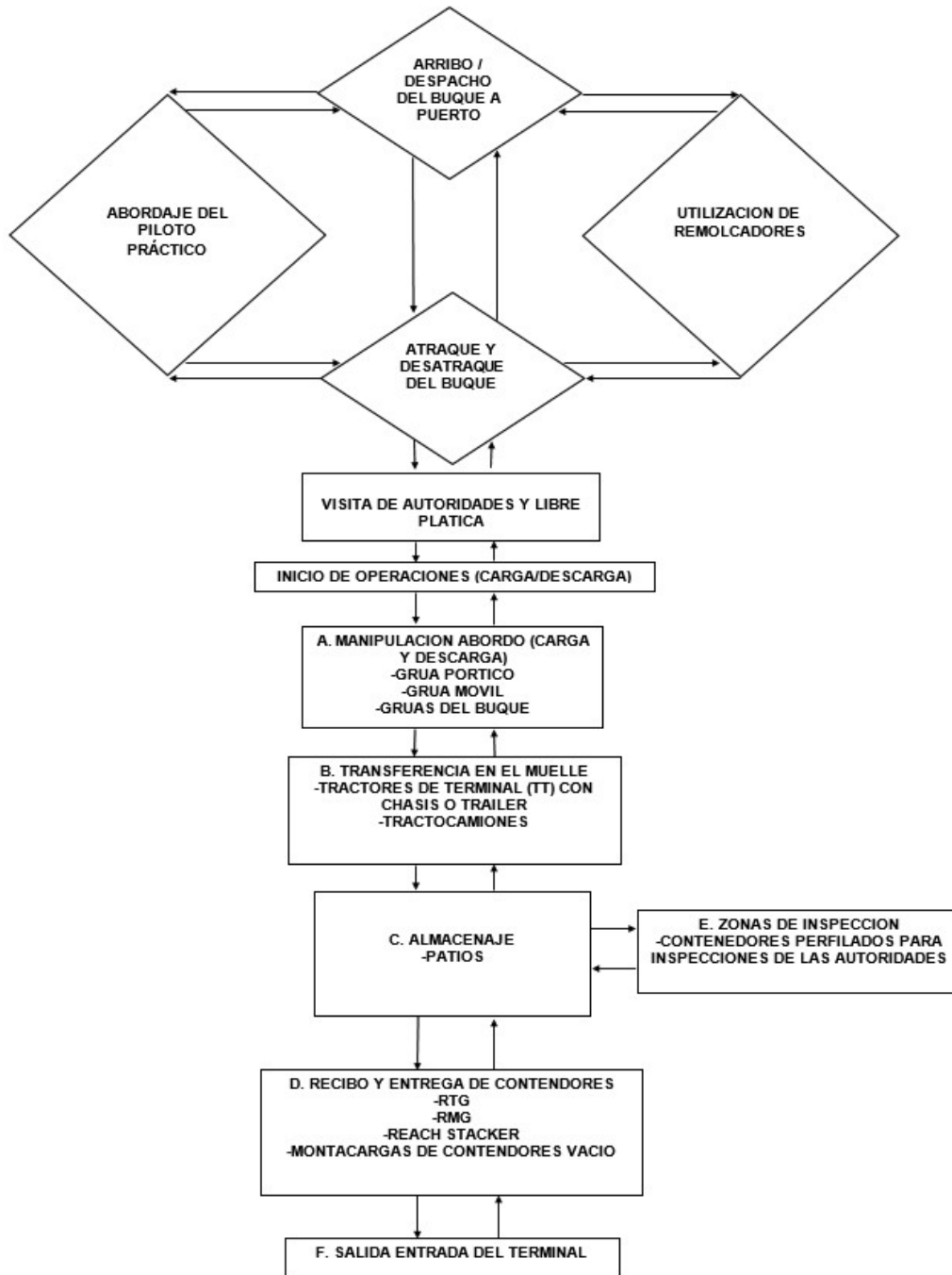



Figure Num. 3.36. Flowchart of operation of containers.

Source: PIO SAS, October 2015.



	ENVIRONMENTAL LICENSE MODIFICATION FOR THE CONSTRUCTION AND OPERATION PROJECT OF A PORT TERMINAL OF SOLID BULK CARGOES IN THE MUNICIPALITY OF TURBO	
	PROJECT DESCRIPTION	Page 83 of 165
	GAT-391-15-CA-AM-PIO-01	Revision: <input type="text"/>

Translation		
	Arrival / Dispatch from the vessel to the dock	
Practical pilot arrival		Use of tugboats
	Docking and undocking of the ship	
	Visit of authorities and free talks	
	Start of operations (Load / Unload)	
	A. On-board handling (loading and unloading) -Gantry crane -Mobile Crane -Ship cranes	
	B. Transfer on the dock - Terminal tractors (TT) with chassis or trailer -Tanker trucks	Inspection areas -Profiled containers for the inspection of the authorities
	C. Storage -Yards	
	D. Receipt and delivery -RTG -RMG -Reach Staker -Empty container forklift	
	Terminal input output	

- **Bulk operation**

Solid Bulk Ship

The unloading configuration of the ships with solid bulks on the docks 1B, 1C and 1D, will be made with the ship cranes, one works like average with three (3) ship

	ENVIRONMENTAL LICENSE MODIFICATION FOR THE CONSTRUCTION AND OPERATION PROJECT OF A PORT TERMINAL OF SOLID BULK CARGOES IN THE MUNICIPALITY OF TURBO	
	PROJECT DESCRIPTION	Page 84 of 165
	GAT-391-15-CA-AM-PIO-01	Revision:

cranes (3 services). Each service will be with a clam (bucket) with a gross capacity of approximately 25 t and a hopper with a capacity of approximately 20 t. The goods will be delivered to the importers at the side of the ship while the storage facilities are made in the onshore terminal. The main types of solid bulks that will be operated are animal feed products, corn, wheat and fertilizers.

In order to unload bulk solids, a mobile gantry crane super post panamax is also planned that will be equipped with a clam (bucket) and a double hopper to load two (2) vehicles simultaneously.

Once specialized bulk facilities are built on land, the merchandise will be delivered to the side of the ship and in the onshore bulk facilities.

The transfer between the ship's side and the onshore facilities will be carried out with specialized vehicles to transport solid bulk; Specialized facilities on land will have the technology to prevent air pollution with particles, and will be made up of batteries of silos and specialized warehouses interconnected by systems of conveyor belts, which will have delivery systems for vehicles loading.





	ENVIRONMENTAL LICENSE MODIFICATION FOR THE CONSTRUCTION AND OPERATION PROJECT OF A PORT TERMINAL OF SOLID BULK CARGOES IN THE MUNICIPALITY OF TURBO		
	PROJECT DESCRIPTION	Page 85 of 165	
	GAT-391-15-CA-AM-PIO-01	Revision:	

Figure Num. 3.37. Specialized vehicles for bulk transport, high speed unloading hopper and coupled tandem.

Source: Study of solid bulk unloading markets in Puerto Bahía Colombia de Urabá, EDIAGRO, 09/2014.



The daily unloading cycle is presented in the following table:

Table Num. 3.16. Bulk loading operation.

NECESSARY VEHICLES			
Maximum unload rate sought	8.000	Daily tons	
Direct load	30%	2.400	t / day
Load to silos	70%	5.600	t / day
Nominal capacity transport equipment	750	Tons / house	
Real average capacity	500	Tons per hour	
Hours of work in real conditions	16		
"Trailers and trucks" capacity	30	Tons	
Mobile hoppers capacity	40	Tons	
Bucket capacity	12	Tons	
Bucket average cycle	2,9	Minutes	
Bucket tons per hour, average	248,3		
Loading time of mobile hopper with buckets	9,7	Minutes	
Truck filling time from mobile hopper	6	Minutes	
Distance platform dock to hopper receipt	5	Km	
Average truck speed	20	km/hour	
Round trip time	15	Minutes	
Time weighing truck on the two scales	10	Minutes	
Time to unload each truck in hopper receipt	5	Minutes	
Loading speed silos, tons per hour	360	Per each hopper	
Time alignment under mobile hopper	2	Minutes	
Hopper truck delivery time	2	Minutes	
Full cycle time trailer-truck	40	Minutes	
Capacity to transport each trailer-truck	45	Tons per hour	
Total trucks per hour	17	To transport the nominal capacity	
Quantity trailers needed to load silos	12		
Quantity trucks load directly	5		

Source: Study of solid bulk unloading markets in Puerto Bahía Colombia de Urabá, EDIAGRO, 09/2014.

The operational flowchart of solid bulk handling in the multipurpose port is presented in the Figure Num. 3.38.

	ENVIRONMENTAL LICENSE MODIFICATION FOR THE CONSTRUCTION AND OPERATION PROJECT OF A PORT TERMINAL OF SOLID BULK CARGOES IN THE MUNICIPALITY OF TURBO	
	PROJECT DESCRIPTION	Page 86 of 165
	GAT-391-15-CA-AM-PIO-01	Revision:

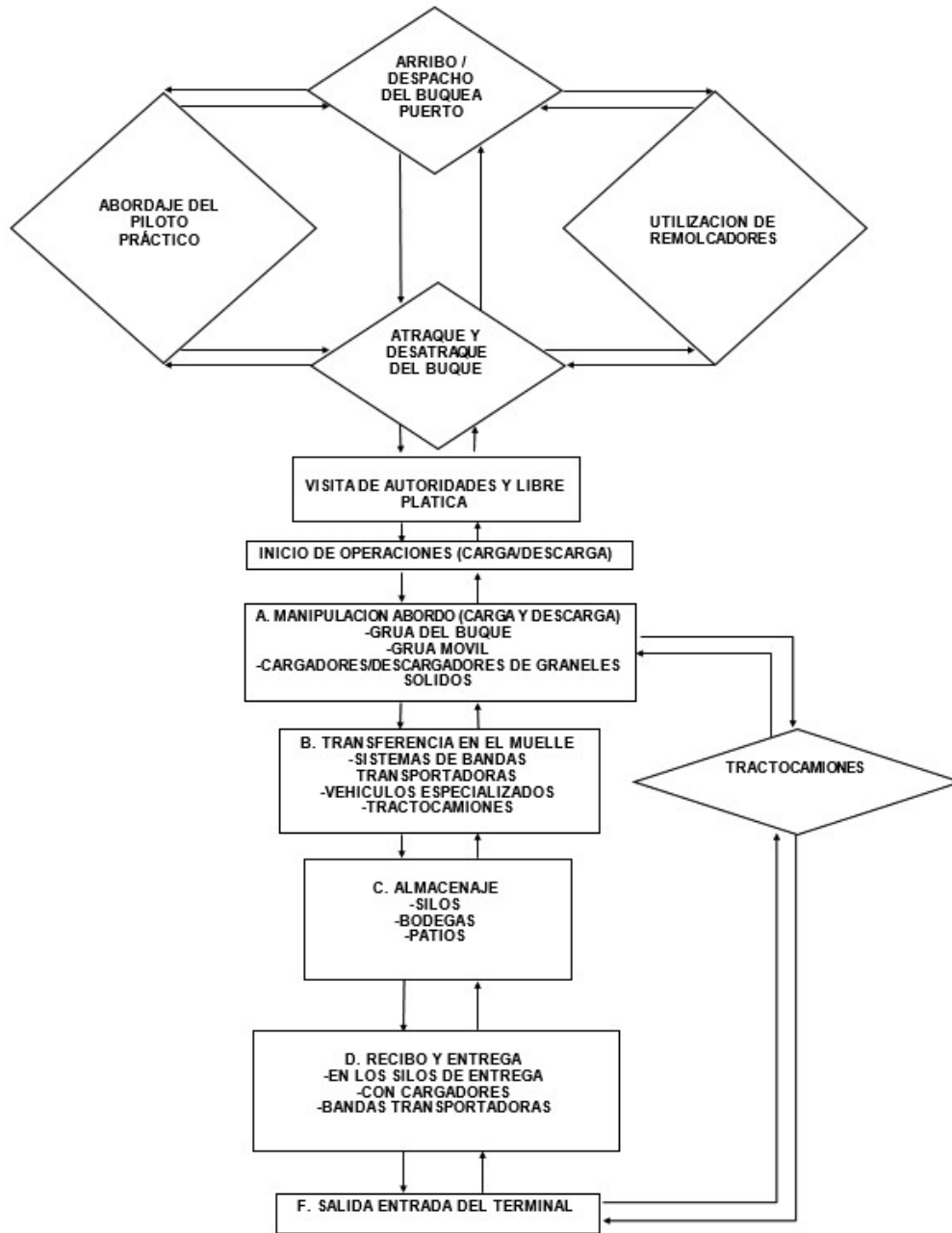





Figure Num. 3.38. Solid bulk operation Flow Chart.
Source: PIO SAS, October 2015.

Figure Translation

	ENVIRONMENTAL LICENSE MODIFICATION FOR THE CONSTRUCTION AND OPERATION PROJECT OF A PORT TERMINAL OF SOLID BULK CARGOES IN THE MUNICIPALITY OF TURBO	
	PROJECT DESCRIPTION	Page 87 of 165
	GAT-391-15-CA-AM-PIO-01	Revision: <input type="text"/>

	Arrival / Dispatch from the vessel to the dock	
Practical pilot arrival		Use of tugboats
	Docking and undocking of the ship	
	Visit of authorities and free talks	
	Start of operations (Load / Unload)	
	B. On-board handling (loading and unloading) -Mobile Crane -Ship cranes -solid bulk loaders / unloaders	
	B. Transfer on the dock -conveyor belt systems -Specialized vehicles -Tanker trucks	Tanker trucks
	E. Storage -Silos -Warehouses -Yards	
	F. Receipt and delivery -In the delivery silos -With loaders -Conveyor belts	
	Terminal input output	

Finally, for the bottom unloading (feeding of materials), it has foreseen of a system of download type Laiding for silos of storage in concrete or steel of conical bottom with approximately 8m diameter and 1.100 m³ of capacity. This system allows the

	ENVIRONMENTAL LICENSE MODIFICATION FOR THE CONSTRUCTION AND OPERATION PROJECT OF A PORT TERMINAL OF SOLID BULK CARGOES IN THE MUNICIPALITY OF TURBO	
	PROJECT DESCRIPTION	Page 88 of 165
	GAT-391-15-CA-AM-PIO-01	Revision:

loading and unloading of silos under a closed system of emissions, either with access design of load truck to the silo or by automated control of closed transport.¹⁴

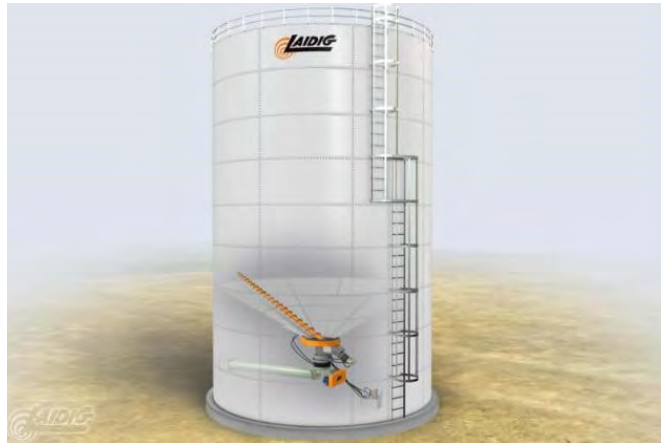

Figure Num. 3.39. Laiding type discharge system.
Source: EDIAGRO, 05/2014.

- **General Cargo Ship**

Vessels with general cargo can be operated on docks 1B, 1C and 1D, the operation of general cargo ships is planned with the ship's own cranes and an average of three (3) cranes of the ship's own are operated (3 services), for the general cargo operation to the side of the ship and in the onshore terminal there is one (1) forklift of 25, one (1) forklift of 16 t, two (2) forklifts of 7.5 t, two (2)) 5 t forklifts, you can also use forklifts of 3.5 t capacity with forks or with gripping devices. The main types of general cargo that we plan to operate are project cargo, steel rolls, paper reels, bales, packaged wood, big bags, etc.

For the operation of heavy and extra-dimensioned cargo, the use of one (1) port mobile crane super post panamax is planned.

¹⁴ Study of solid grains unloading markets in Puerto Bahía Colombia of Urabá Puerto Bahía Colombia of Urabá Puerto Bahía Colombia de Urabá, EDIAGRO, 09/2014.

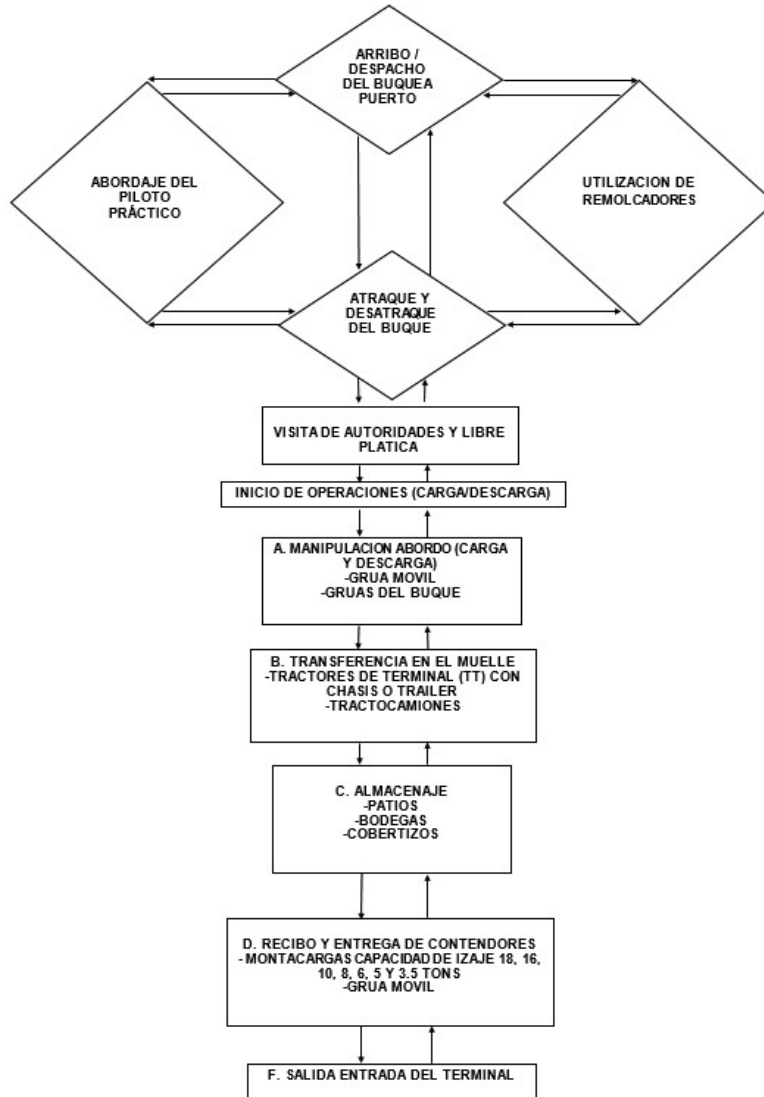



Figure Num. 3.40. Flow diagram of general cargo operation.
Source: PIO SAS, October 2015.

Figure Translation		
	Arrival / Dispatch from the vessel to the dock	
Practical pilot arrival		Use of tugboats
	Docking and undocking of the ship	



	ENVIRONMENTAL LICENSE MODIFICATION FOR THE CONSTRUCTION AND OPERATION PROJECT OF A PORT TERMINAL OF SOLID BULK CARGOES IN THE MUNICIPALITY OF TURBO	
	PROJECT DESCRIPTION	Page 90 of 165
	GAT-391-15-CA-AM-PIO-01	Revision:

	Visit of authorities and free talks	
	Start of operations (Load / Unload)	
	C. On-board handling (loading and unloading) -Mobile Crane -Ship cranes	
	B. Transfer on the dock -Terminal tractors (TT) with chassis or trailer -Tanker trucks	
	G. Storage -Yards -Warehouses -Sheds	
	H. Receipt and delivery -lift trucks with lifting capacity 18,16, 10, 8, 6, 5, 3.5 tons -Mobile Crane	
	Terminal input output	

- **Roll-On Roll-Off Ships**

The unloading operation is planned with a group of certified drivers who will transfer the vehicles from the ship's board to the storage site in the onshore terminal, will also receive export vehicles in the onshore terminal and the drivers will have the responsibilities to move it from the storage area to on board the ship. The unloading of all rolling vehicles (cars, tractors, retro-trimmers, etc.) is planned. These ships are designed to transport a wide variety of types of rolling vehicles for import, export and transshipment and even have the possibility of transporting chassis, platforms, trailers with heavy loads.

The operation flowchart of the load-and-unload Roll-on Roll-off (Ro-Ro) operation is presented in the Figure Num. 3.41.

	ENVIRONMENTAL LICENSE MODIFICATION FOR THE CONSTRUCTION AND OPERATION PROJECT OF A PORT TERMINAL OF SOLID BULK CARGOES IN THE MUNICIPALITY OF TURBO	
	PROJECT DESCRIPTION	Page 91 of 165
	GAT-391-15-CA-AM-PIO-01	Revision:

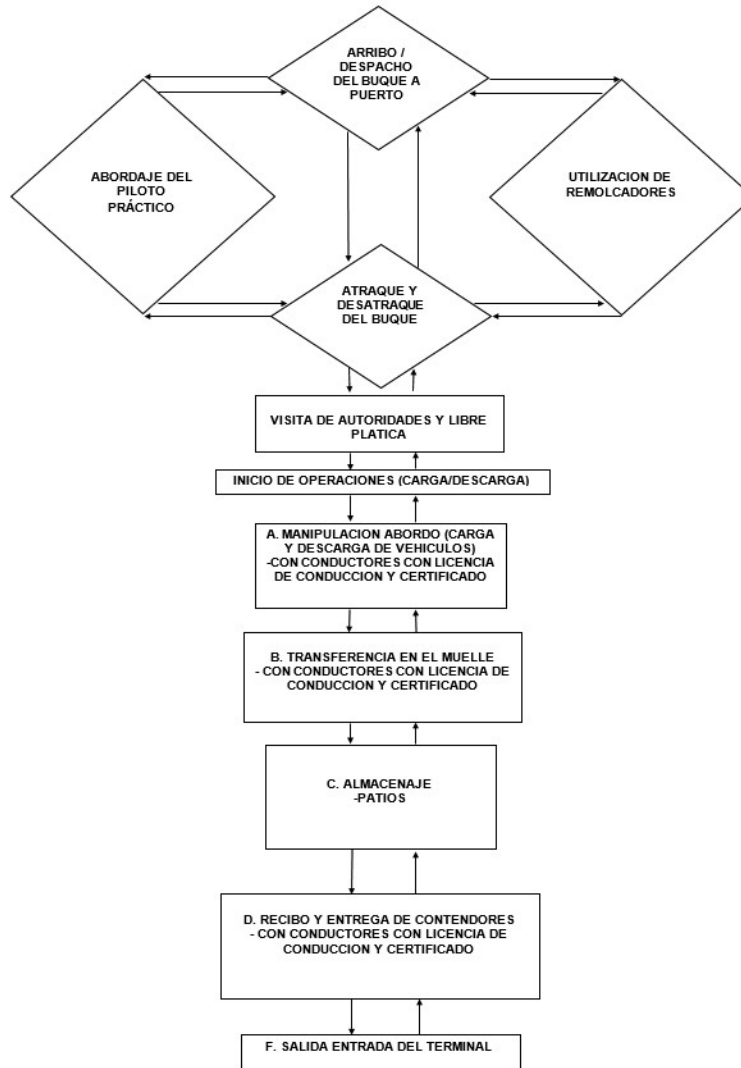



Figure Num. 3.41. Flow chart of Ro-Ro operation.
Source: PIO SAS, October 2015.

Figure Translation		
	Arrival / Dispatch from the vessel to the dock	
Practical pilot arrival		Use of tugboats
	Docking and undocking of the ship	

	ENVIRONMENTAL LICENSE MODIFICATION FOR THE CONSTRUCTION AND OPERATION PROJECT OF A PORT TERMINAL OF SOLID BULK CARGOES IN THE MUNICIPALITY OF TURBO	
	PROJECT DESCRIPTION	Page 92 of 165
	GAT-391-15-CA-AM-PIO-01	Revision:

	Visit of authorities and free talks	
	Start of operations (Load / Unload)	
	D. On-board handling (loading and unloading) -With drivers with a driving license and certificate	
	B. Transfer on the dock -With drivers with a driving license and certificate	
	I. Storage -Yards	
	J. Receipt and delivery -With drivers with a driving license and certificate	
	Terminal input output	



- **Ships with Wood Chips**

By means of a wood chip loader (Ship Loader) the ship will be loaded. The wood chips will arrive in bulk along the side of the ship in vehicles and will be deposited on the slab of the dock by means of front loaders and will move from the slab of the dock to the loader.

- **Operation Ships with liquid cargo.**

Operation of Tankers.

The multipurpose terminal of Puerto Bahía Colombia de Urabá will operate tankers with liquid cargo other than oil and its derivatives, such as vegetable oils, mineral oils, baits, among others. The download will be made with the specialized systems of tankers, the cargo will be made with an external specialized mobile or fixed pumping system, typical of the liquid cargo ship.



	ENVIRONMENTAL LICENSE MODIFICATION FOR THE CONSTRUCTION AND OPERATION PROJECT OF A PORT TERMINAL OF SOLID BULK CARGOES IN THE MUNICIPALITY OF TURBO	 aqua & terra
	PROJECT DESCRIPTION	Page 93 of 165
	GAT-391-15-CA-AM-PIO-01	Revision:

The product that will arrive at the port in tank trucks and will be unloaded to be stored in the tanks of the facility on land, on the other hand, the liquid bulk will arrive at the port in ships, where they will be driven or transported to the respective tanks, by tank trucks or the poliduct (line of pipe that will transport the liquid bulk) and finally dispatched to tank trailer.

Unloading tanker trucks will be carried out in an area called unloading, which is carried out below the tanker, through a system of receiving pumps, the product will be conducted to the storage tanks. From there, the bulk will be pumped and to the maritime dock.

Although these types of liquids are considered as low flash point liquids, it has been taken as a contingency and control measure that in the unloading areas there will be 5 portable fire extinguishers per unloading unit and monitors of water - foam. In addition, in the storage area of tanks, contained in dams, two (2) fire system monitors (SCI) per dike will be available. Finally, and as a last line of contingency, Puerto Bahía Colombia de Urabá will have a team of firefighters, in charge of port security and prevention of a fire contingency.

The flowchart of the operating process for liquid bulks is presented in the Figure Num. 3.42.

	ENVIRONMENTAL LICENSE MODIFICATION FOR THE CONSTRUCTION AND OPERATION PROJECT OF A PORT TERMINAL OF SOLID BULK CARGOES IN THE MUNICIPALITY OF TURBO	
	PROJECT DESCRIPTION	Page 94 of 165
	GAT-391-15-CA-AM-PIO-01	Revision:

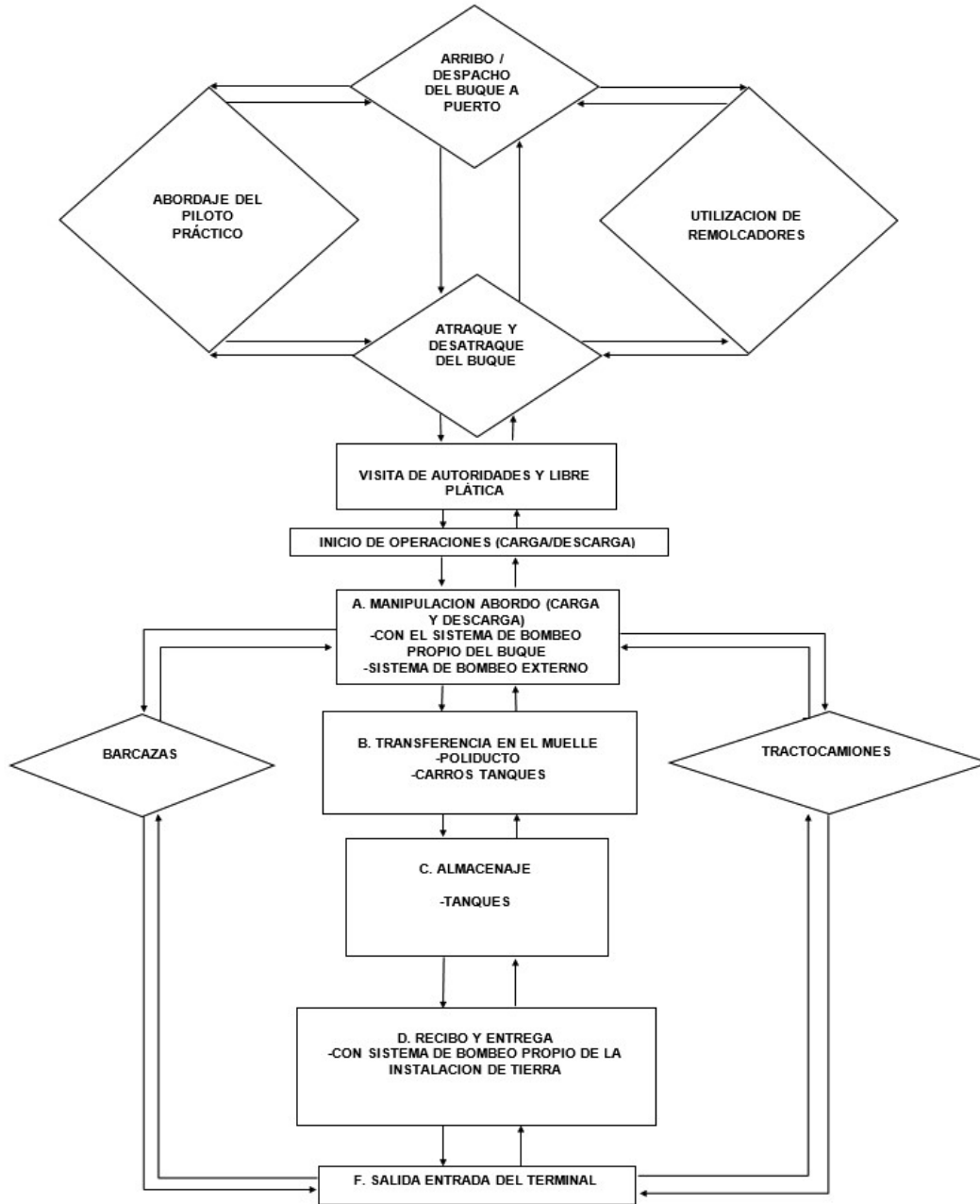



Figure Num. 3.42. Liquid bulk operation flux chart.
Source: PIO SAS, October 2015.



Figure Translation

	ENVIRONMENTAL LICENSE MODIFICATION FOR THE CONSTRUCTION AND OPERATION PROJECT OF A PORT TERMINAL OF SOLID BULK CARGOES IN THE MUNICIPALITY OF TURBO	
	PROJECT DESCRIPTION	Page 95 of 165
	GAT-391-15-CA-AM-PIO-01	Revision:

	Arrival / Dispatch from the vessel to the dock	
Practical pilot arrival		Use of tugboats
	Docking and undocking of the ship	
	Visit of authorities and free talks	
	Start of operations (Load / unload)	
	E. On-board handling (loading and unloading) - With the ship's own pumping system - external pumping system	
Barges	B. Transfer on the dock - Poliduct - Tanker trucks	Tractor trucks
	K. Storage - Tanks	
	L. Receipt and delivery - With the ground installation pump system	
	Terminal input output	

3.2.6.2 Machinery

Next, the main machinery for the loading / unloading operation of the commercial activities of Puerto Bahía Colombia de Urabá.

	ENVIRONMENTAL LICENSE MODIFICATION FOR THE CONSTRUCTION AND OPERATION PROJECT OF A PORT TERMINAL OF SOLID BULK CARGOES IN THE MUNICIPALITY OF TURBO	
	PROJECT DESCRIPTION	Page 96 of 165
	GAT-391-15-CA-AM-PIO-01	Revision: <input type="text"/>





New Post Panamax Gantry Cranes



Liebherr Mobile Crane Model LHM 550



RTG (Rubber Tyred Granty crane)

	<p align="center">ENVIRONMENTAL LICENSE MODIFICATION FOR THE CONSTRUCTION AND OPERATION PROJECT OF A PORT TERMINAL OF SOLID BULK CARGOES IN THE MUNICIPALITY OF TURBO</p>	
	<p align="center">PROJECT DESCRIPTION</p>	<p align="center">Page 97 of 165</p>
	<p align="center">GAT-391-15-CA-AM-PIO-01</p>	<p>Revision: <input type="text"/></p>



Refrigerated storage racks





Reach staker



Side Handler



	ENVIRONMENTAL LICENSE MODIFICATION FOR THE CONSTRUCTION AND OPERATION PROJECT OF A PORT TERMINAL OF SOLID BULK CARGOES IN THE MUNICIPALITY OF TURBO	
	PROJECT DESCRIPTION	Page 98 of 165
	GAT-391-15-CA-AM-PIO-01	Revision:

Shovel for bulk





Bulk hopper

Photo Num. 3.7. Main Machinery of Puerto Bahía Colombia de Urabá.

Source: PIO SAS, October 2015.

3.3 Handling and disposal of leftover materials from excavation and debris

As mentioned in previous paragraphs, the project of Puerto Bahía Colombia de Urabá will not have any excavation material, since all the material coming from the descapote and cleaning will be used in the generation of jars and protection of the banks of The León Riiver. However, in case of debris generation during the construction process, these will be disposed in the dump closest to the project area (see Figure Num. 3.43).

	ENVIRONMENTAL LICENSE MODIFICATION FOR THE CONSTRUCTION AND OPERATION PROJECT OF A PORT TERMINAL OF SOLID BULK CARGOES IN THE MUNICIPALITY OF TURBO	
	PROJECT DESCRIPTION	Page 99 of 165
	GAT-391-15-CA-AM-PIO-01	Revision:

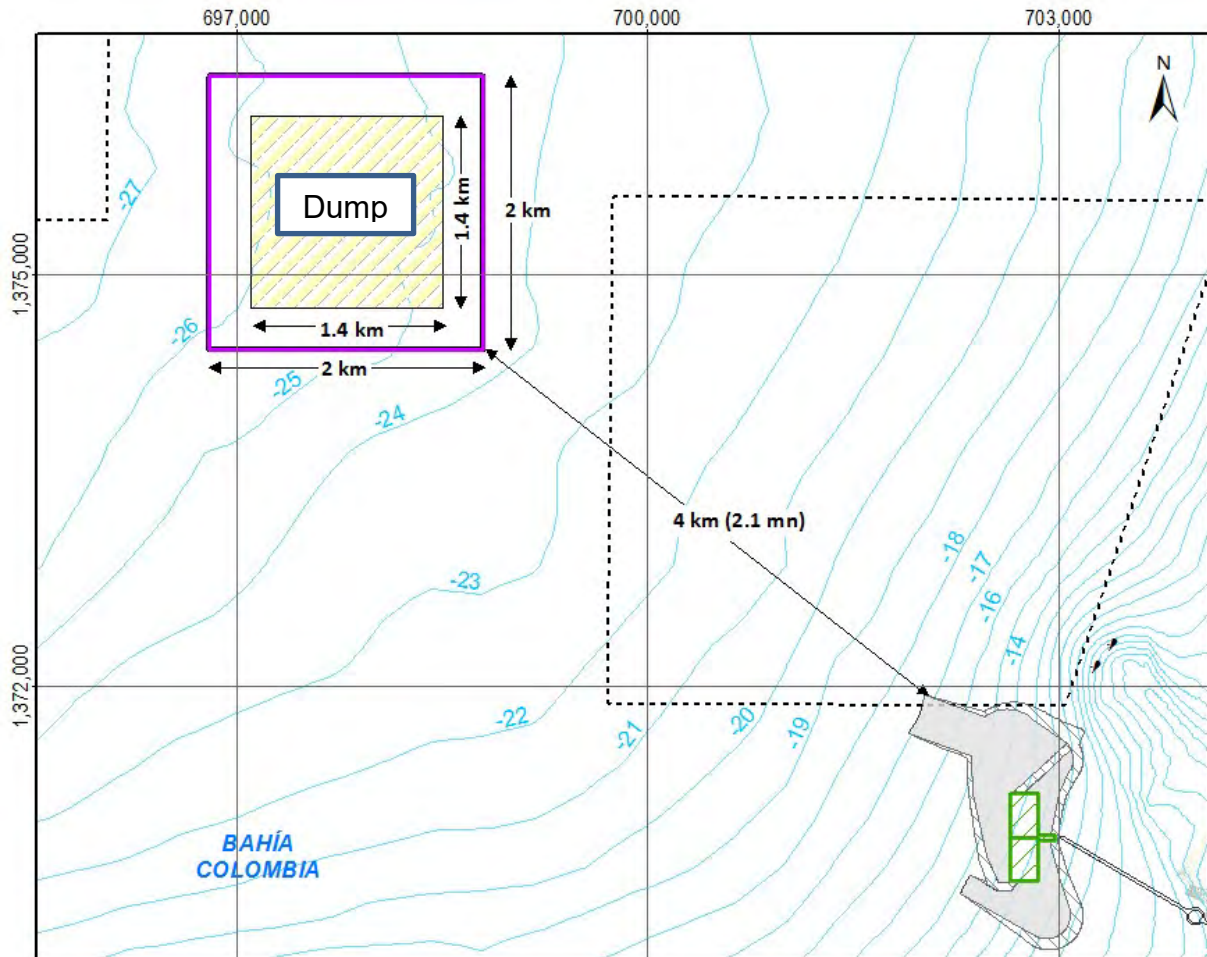



Figure Num. 3.43. Location of dump and dispersion limit.
Source: Aqua & Terra Consultores Asociados SAS.

The coordinates of the area of dredging or unloading of material from dredging have been mentioned in the numeral 3.2.3.1.6.

3.3.1 Handling and disposal of dredged materials

The disposition of the dredging material from the maneuvering areas and access channels will be arranged in the dump area that is sought to be licensed in this modification of the Environmental License. Area located 4.1 km between the dredging and dump polygons. The dimensions of the area destined for the dump are 1400 m by 1400 m, with an area of influence of 2000 m by 2000 m.

3.3.2 Modeling of dredging and dispersion of sediments

	ENVIRONMENTAL LICENSE MODIFICATION FOR THE CONSTRUCTION AND OPERATION PROJECT OF A PORT TERMINAL OF SOLID BULK CARGOES IN THE MUNICIPALITY OF TURBO	
	PROJECT DESCRIPTION	Page 100 of 165
	GAT-391-15-CA-AM-PIO-01	Revision:

The bathymetry used for the location and characterization of the dump area of the materials from the dredging of Puerto Bahía Colombia de Urabá, was obtained from the nautical charts supplied by the General Maritime Directorate and prepared by the Oceanographic and Hydrographic Research Center - CIOH¹⁵, the nautical charts that contain the study area are 412 and 625, which is shown in the Figure Num. 3.44. Additionally, a detailed bathymetry of the sector proposed for the dump (carried out by Batistudios S.A.S, in July 2015) was carried out (see Figure Num. 3.45).

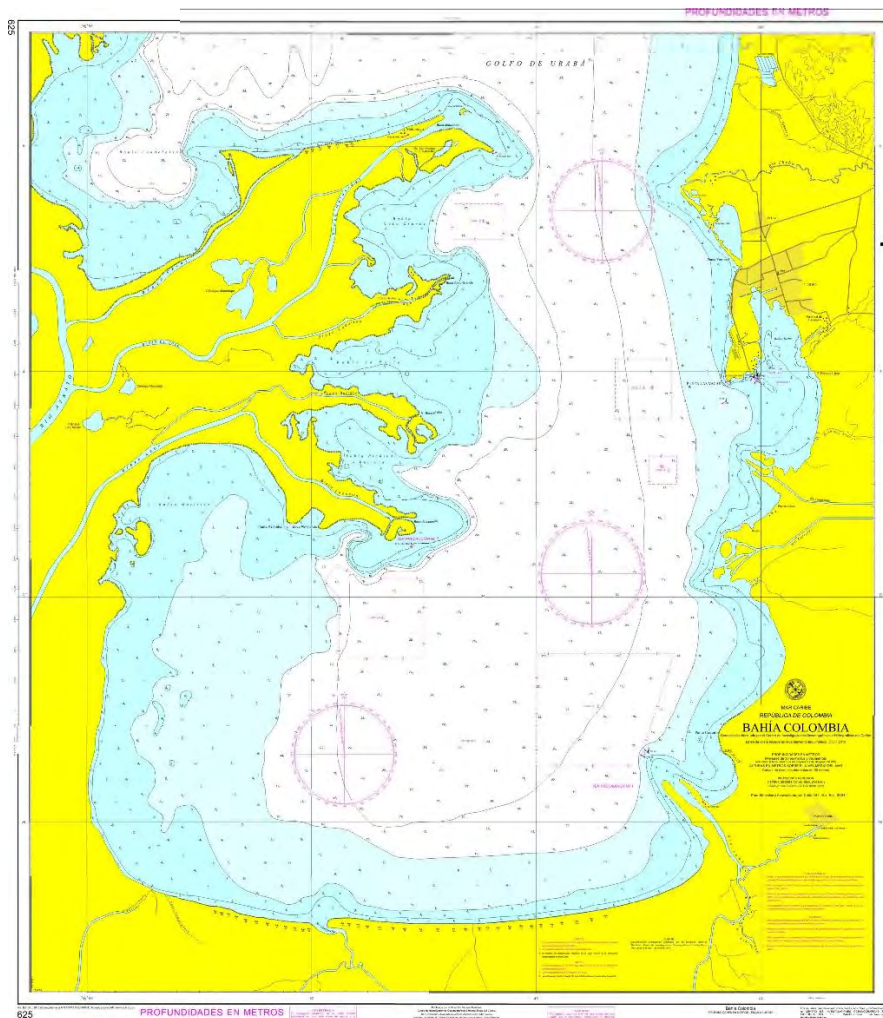

¹⁵ MARITIME DIRECTORATE GENERAL (DIMAR) and CENTER OF OCEANOGRAPHIC AND HYDROGRAPHIC INVESTIGATIONS (CIOH). Cartographic Atlas of the Oceans and Coasts of Colombia. 2nd edition. Publication 3007. Bogotá: 2005. 105 p



	ENVIRONMENTAL LICENSE MODIFICATION FOR THE CONSTRUCTION AND OPERATION PROJECT OF A PORT TERMINAL OF SOLID BULK CARGOES IN THE MUNICIPALITY OF TURBO	
	PROJECT DESCRIPTION	Page 101 of 165
	GAT-391-15-CA-AM-PIO-01	Revision:



Figure Num. 3.44. Nautical chart 625.¹⁶
Source: General Maritime Directorate -DIMAR.



Figure Num. 3.45. Detail bathymetry of the dump area.
Source: Aqua&Terra Consultores Asociados S.A.S, 2015.

With the bathymetries obtained from these two sources of information, we proceeded to interpolate the information to obtain a digital depth model, in order to locate and later model the effects of the material dumping in the study area. The interpolated bathymetry is shown in the Figure Num. 3.46

¹⁶ MARITIME DIRECTORATE GENERAL (DIMAR) and CENTER OF OCEANOGRAPHIC AND HYDROGRAPHIC INVESTIGATIONS (CIOH). Cartographic Atlas of the Oceans and Coasts of Colombia. 2nd edition. Publication 3007. Bogotá: 2005. 105 p.

	ENVIRONMENTAL LICENSE MODIFICATION FOR THE CONSTRUCTION AND OPERATION PROJECT OF A PORT TERMINAL OF SOLID BULK CARGOES IN THE MUNICIPALITY OF TURBO	
	PROJECT DESCRIPTION	Page 102 of 165
	GAT-391-15-CA-AM-PIO-01	Revision:

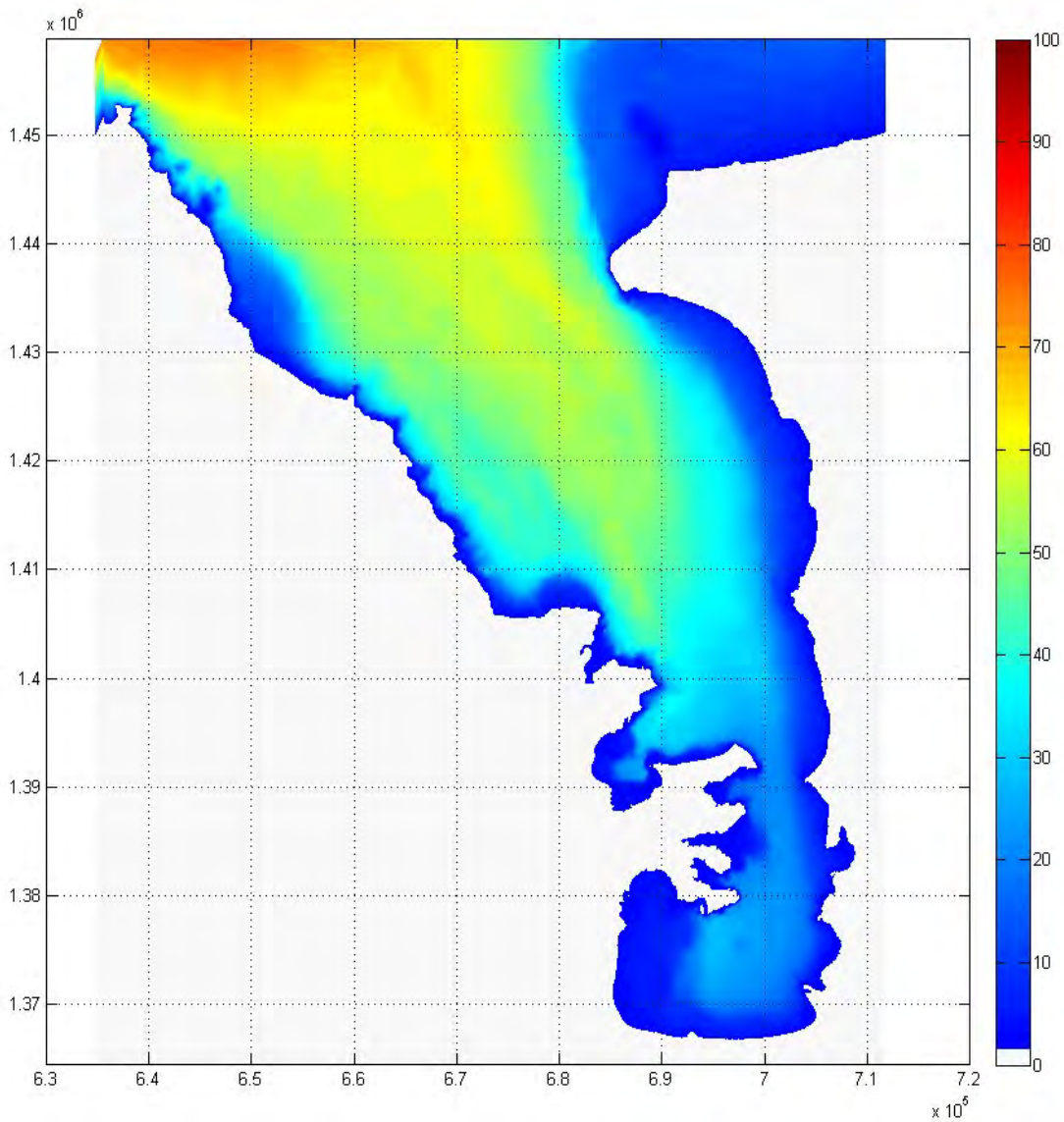



Figure Num. 3.46. Bathymetry of the Golfo de Urabá
Source: Aqua&Terra Consultores Asociados S.A.S, 2015.

	ENVIRONMENTAL LICENSE MODIFICATION FOR THE CONSTRUCTION AND OPERATION PROJECT OF A PORT TERMINAL OF SOLID BULK CARGOES IN THE MUNICIPALITY OF TURBO	
	PROJECT DESCRIPTION	Page 103 of 165
	GAT-391-15-CA-AM-PIO-01	Revision:

Dispersion model of the dredged material

The effects of dredging processes have been extensively studied through laboratory experiments¹⁷. However, the development of mathematical models allows predicting these effects in any situation without the need to resort to physical trials.

Currently, sediment transport models are capable of reproducing the variation of the seafloor due to the effect of dredging operations, analyzing the evolution of suspended solids in the water column.^{18 19 20 21}

In the IH-Dredge methodology, developed by the IH Cantabria^{22 23} and modified by Aqua & Terra Consultores joins the use of the Morphodynamic module of the Delft3D²⁴ model, which allows to simulate the evolution of sediments in the water column, with a set of scripts that allow that the model simulate in real time different dredging techniques, both mechanical and hydraulic.

In Golfo de Urabá, León and Atrato rivers, constitute the main source of sediments, composed mainly of fine silts, which gives rise to the formation of a pen of solids in suspension, of variable extension and concentration depending on the weather conditions.

In this study the modeling of the dispersion of solid material losses due to the dredging of Puerto Bahía Colombia de Urabá is made, considering also the sediments introduced in León and Atrato rivers. This way, it will be possible to know the concentrations of suspended solids that, naturally, get into the rivers, which will facilitate the evaluation of the impact produced by the dispersion of the dredged material on the levels of turbidity.

In the modeling process of dredging, the first step is to obtain the trajectory of it. To do this, the dredged object cells (and how much) are counted by means of an algorithm until reaching the target depth in the study area. Figure Num. 3.47 shows

¹⁷ Vlasbom, W. Design of Dredging Equipment, Delft University of Technology. 2005

¹⁸ Song, Y. T. and Haidvogel, D. A semi-implicit primitive equation ocean circulation model using a generalized topography following coordinate system. 1994 En: J. Comput. Phys..vol. 115, p. 228–244.

¹⁹ Jacobsen, F. and Rasmussen, E. B. MIKE 3 MT: A 3-dimensional mud transport model, Technical rep. DG-12 to the commission of the european communities, Danish Hydraulic Institute, Hørsholm, Denmark. 1997



²⁰ Deltares. Delft3D user's manual, Tech. rep., Deltares, The Netherlands. 1999

²¹ Bai, Y., Wang, Z., and Shen, H. Three-dimensional modelling of sediment transport and the effects of dredging in the Haihe Estuary. En: Estuarine, Coastal and Shelf Science. 2003. vol. 56, p. 175–186.

²² García J., Gómez A.G., Sámano, M.L., García A., Juanes, J.A. Development of the IH-Dredge model. Application to the estimation of environmental risk in dredging processes. 2013. In: XII Spanish Conference on Coastal and Port Engineering.

²³ García J., Sámano M.L., Gómez, A.G., García, A., Juanes, J.A. A 3D model to analyze environmental effects of different dredging operations. Application to the Port of Marin. 2013. En: 8th Symposium on River, Coastal and Estuarine Morphodynamics.

²⁴ Deltares. Op.cit.

	ENVIRONMENTAL LICENSE MODIFICATION FOR THE CONSTRUCTION AND OPERATION PROJECT OF A PORT TERMINAL OF SOLID BULK CARGOES IN THE MUNICIPALITY OF TURBO	
	PROJECT DESCRIPTION	Page 104 of 165
	GAT-391-15-CA-AM-PIO-01	Revision:

the dredging trajectory schematic simulating the IH-Dredge methodology when performing an operation with a cutting suction dredger.

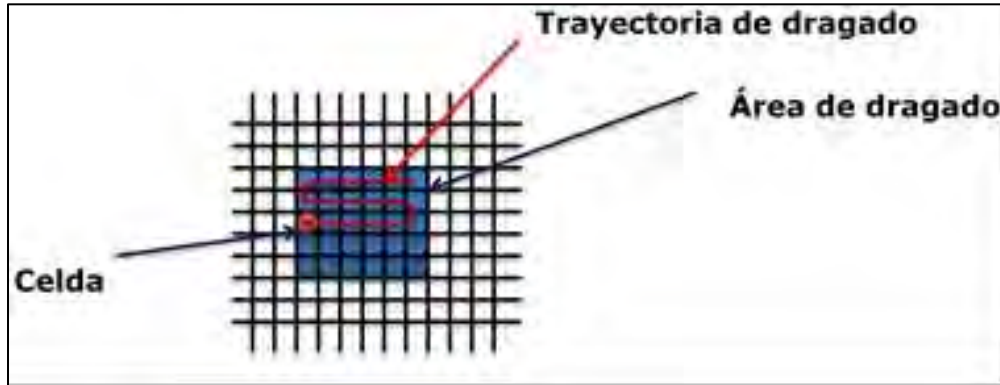



Figure Num. 3.47. Evaluation of the dredging trajectory for the suction dredge
Source: Aqua&Terra Consultores Asociados S.A.S, 2015.

Figure Translation
Left: Cell
Top: Dredging trajectory
Top right: Dredging area

Once the dredging trajectory has been obtained, the methodology shown in the Figure Num. 3.49 to carry out the simulation of the dredging operation Puerto Bahía Colombia de Urabá.

Figure Num. 3.49, It's based in the methodology where the solid flow starts the dredge per second, the dredging trajectory and the target level that is intended to be reached in the study area.

Next, the set of scripts of the IH-Dredge methodology generate the files that will allow Delft3D (as a sediment transport model) to evaluate the continuous dredging with its associated losses. With this methodology, it's achieved that the model keeps dredging each cell until it reaches the target level within the study area, dredging at the rate of the solid flow of the dredge as time passes.

	ENVIRONMENTAL LICENSE MODIFICATION FOR THE CONSTRUCTION AND OPERATION PROJECT OF A PORT TERMINAL OF SOLID BULK CARGOES IN THE MUNICIPALITY OF TURBO	
	PROJECT DESCRIPTION	Page 105 of 165
	GAT-391-15-CA-AM-PIO-01	Revision:

If the barge reaches the overflow level, surface losses begin to be introduced due to the overflow in the cell in which it is being dredged. Once the maximum capacity of the hopper has been reached, it moves to the dump and all the extracted material is unloaded on the surface. With respect to the methodology proposed by IH Cantabria, the modeling of the dispersion in the dump of Puerto Bahía Colombia de Urabá has a modification in the dumping of material. The modification made by Aqua & Terra associated consultants, is based on the fact that the material was downloaded following a trajectory inside the cells that make up the dump, trying to get closer to the real way in which this type of unloading is made and not as proposed by IH-Cantabria, which is to do it in a single point.

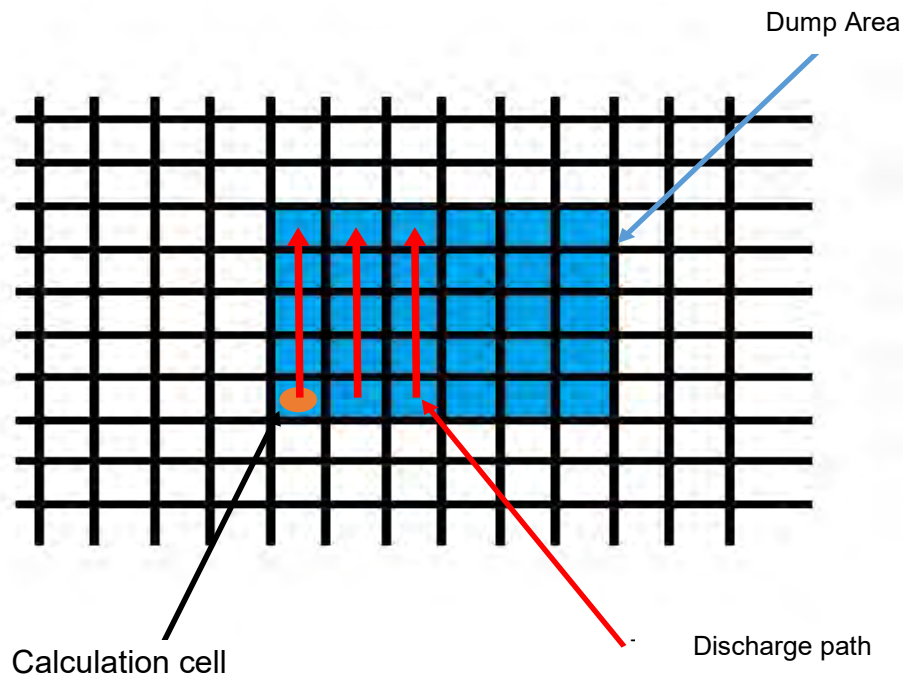

Figure Num. 3.48. Trajectory material dumping in the dump
Source: Aqua&Terra Consultores Asociados S.A.S, 2015.

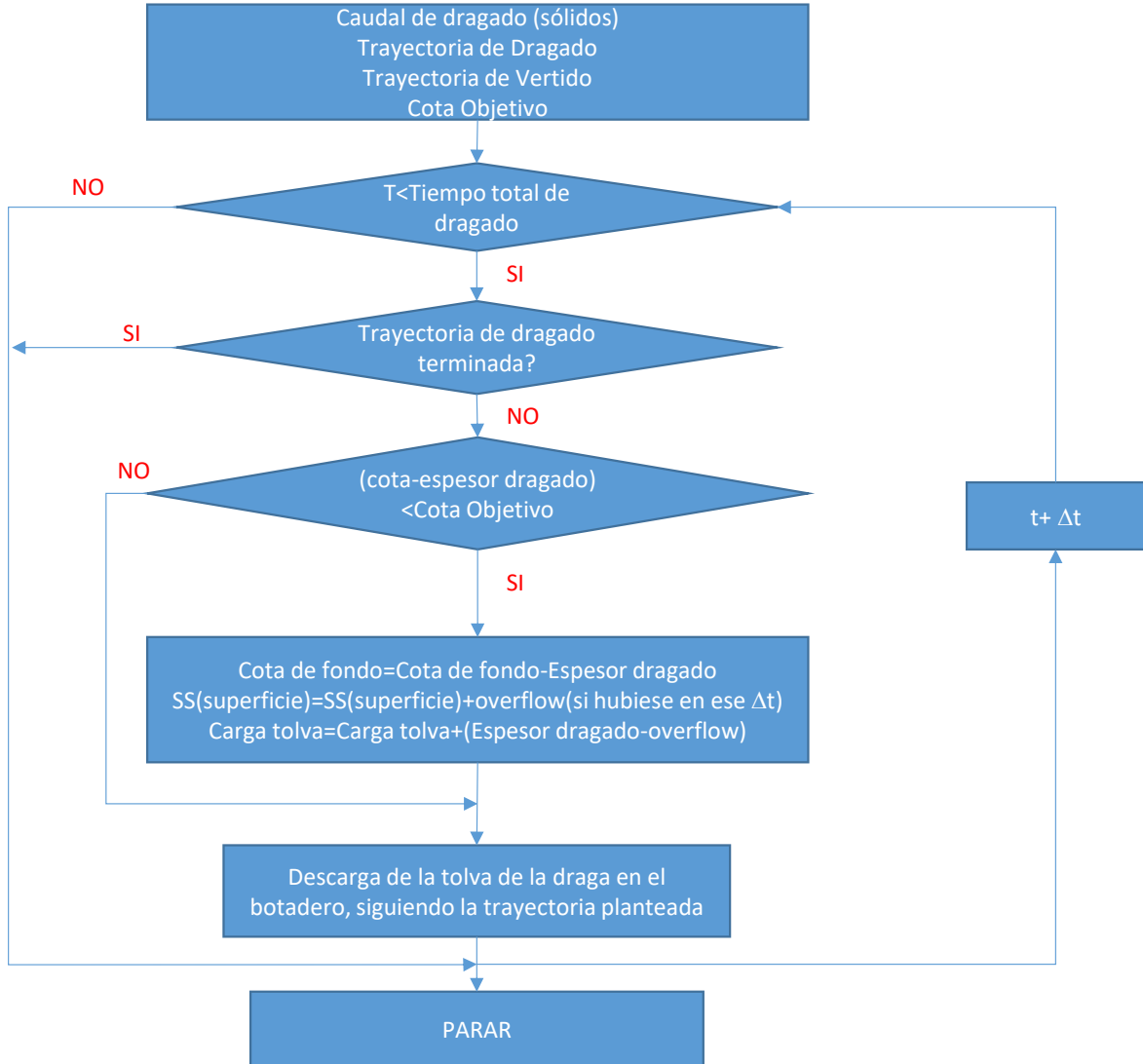



Figure Num. 3.49. Operation diagram of the IH-Dredge methodology (modified by Aqua & Terra Consultores S.A.S) for the simulation of a real-time dredging process with a suction dredger. Source: Aqua&Terra Consultores Asociados S.A.S, 2015.

Translation
dredging flow
dredging trajectory
discharge trajectory
target dimension
T < Total dredging time

	ENVIRONMENTAL LICENSE MODIFICATION FOR THE CONSTRUCTION AND OPERATION PROJECT OF A PORT TERMINAL OF SOLID BULK CARGOES IN THE MUNICIPALITY OF TURBO	
	PROJECT DESCRIPTION	Page 107 of 165
	GAT-391-15-CA-AM-PIO-01	Revision:

Dredging trayjectory finished?
(level-thickness dredging) <target level
bottom level= bottom level-dredging thickness SS(surface)=SS(surface)+overflow (if there was at that Δt) Hopper load=hopper load (dredging thickness - overflow)
discharge the hopper from the dredger in the dump, following the planned path
STOP

Next, the sediment in the water column is modeled with the morphodynamic module of Delft3D, obtaining its dispersion in the area where Puerto Bahía Colombia de Urabá and the dump are located. With these results, we will study the temporal evolution of the concentration of surface solids in a set of points that will be located in the periphery of the dump and in the area of dredging.

Morphodynamic module of the Delft3D model



The Delft3D model includes a module that calculates the sediment transport and the morphological changes derived from it. Through its application, it is possible to calculate the transport of suspended solids, both for cohesive and non-cohesive material, as well as the transport of non-cohesive material per bottom. This module allows to consider different sediment fractions, according to size and density, that do not interact with each other.

The three-dimensional transport of suspended solids is calculated by solving the three-dimensional advection-diffusion equation for suspended solids (see Equation 3.1):

$$\frac{\partial c^{(1)}}{\partial t} + \frac{\partial uc^{(1)}}{\partial x} + \frac{\partial vc^{(1)}}{\partial y} + \frac{\partial (w - w_s^{(1)})c^{(1)}}{\partial z} - \frac{\partial}{\partial x} \left(\varepsilon_{s,x}^{(1)} \frac{\partial c^{(1)}}{\partial x} \right) - \frac{\partial}{\partial y} \left(\varepsilon_{s,y}^{(1)} \frac{\partial c^{(1)}}{\partial y} \right) - \frac{\partial}{\partial z} \left(\varepsilon_{s,z}^{(1)} \frac{\partial c^{(1)}}{\partial z} \right) = 0$$

Equation 3.1 Three-dimensional advection equation - diffusion for suspended solids

Where, $c^{(1)}$ is the mass concentration of the sediment fraction (l) (Kg/m^3), u, v, w are the components of the flow velocity (m/s), $\varepsilon_{s,x}^{(1)}, \varepsilon_{s,y}^{(1)}, \varepsilon_{s,z}^{(1)}$ are the diffusion coefficients

	ENVIRONMENTAL LICENSE MODIFICATION FOR THE CONSTRUCTION AND OPERATION PROJECT OF A PORT TERMINAL OF SOLID BULK CARGOES IN THE MUNICIPALITY OF TURBO	
	PROJECT DESCRIPTION	Page 108 of 165
	GAT-391-15-CA-AM-PIO-01	Revision:

of the sediment fraction (l) (m^2/s) y $w_s^{(l)}$ is the sedimentation rate of the sediment fraction (l) (m/s).

The use of the morphodynamic module, introduces the effect of the sediment fractions to calculate the density of the fluid mixture of sediment and water ρ_{mix} .

This effect on the density of water, obtained as a function of salinity and temperature in the absence of sediments, is calculated with the following relationship when the medium has a certain concentration of them (see Equation 3.2):

$$\rho_{mix}(S, c^{(l)}) = \rho_w(S) + \sum_{l=1}^{l_{sed}} c^{(l)} \left(1 - \frac{\rho_w(S)}{\rho_s^{(l)}} \right)$$

Equation 3.2 Equation of the density of the fluid mixture of sediment and water ρ_{mix}

Where, S is the concentration of salinity (ppt), $\rho_w(S)$ is the specific density of water with a concentration of salinity S (Kg/m^3), $\rho_s^{(l)}$ is the specific density of the sediment fraction (l) (Kg/m^3) y l_{sed} is the number of sediment fractions.



According to the characteristics of the solid material transported, the Delft3D model uses different formulations to model its transport, being the differential characteristic the fact of being cohesive or non-cohesive sediment.

Cohesive sediment

In salt water, cohesive sediments tend to form sediment flocs, with a degree of flocculation depending on the concentration of salinity in the medium. These flocs, much larger than the individual sediment particles, have a higher sedimentation rate. The sedimentation velocity of the cohesive sediment flocs is calculated with the following expression (see Equation 3.3):

$$w_{s,0}^{(l)} = \begin{cases} \frac{w_{s,max}^{(l)}}{2} \left(1 - \cos \left(\frac{\pi S}{S_{max}} \right) \right) + \frac{w_{s,f}^{(l)}}{2} \left(1 + \cos \left(\frac{\pi S}{S_{max}} \right) \right), & si S \leq S_{max} \\ w_{s,max}^{(l)}, & si S < S_{max} \end{cases}$$

Equation 3.3 Equation to calculate the sedimentation velocity of cohesive sediment flocs

	ENVIRONMENTAL LICENSE MODIFICATION FOR THE CONSTRUCTION AND OPERATION PROJECT OF A PORT TERMINAL OF SOLID BULK CARGOES IN THE MUNICIPALITY OF TURBO	
	PROJECT DESCRIPTION	Page 109 of 165
	GAT-391-15-CA-AM-PIO-01	Revision:

Where, $w_{s,0}^{(l)}$ is the sedimentation rate (not attenuated) of the sediment fraction (l), $w_{s,max}^{(l)}$ is the sedimentation rate of the sediment fraction (l) for the maximum salinity concentration, $w_{s,f}^{(l)}$ is the sedimentation rate in fresh water of the sediment fraction (l) y S_{max} is the maximum specified salinity for $w_{s,max}^{(l)}$.

In the evaluation of the dispersion of the cohesive sediment, the diffusion coefficient is equal to the one used by the model to solve the hydrodynamics and does not take into account the increase of the turbulence due to the swell.



The calculation of the erosion and deposition of cohesive sediment, that is to say, the flows of the fractions of cohesive sediment between the water column and the bed, is carried out with the Partheniades-Krone formulations (see Equation 3.4 Partheniades, 1965).

$$E^{(1)} = M^{(1)} S(\tau_{cw}, \tau_{cr,e}^{(1)}) \quad D^{(1)} = w_s^{(1)} c_b^{(1)} S(\tau_{cw}, \tau_{cr,d}^{(1)})$$

$$c_b^{(1)} = c^{(1)} \left(z = \frac{\Delta z_b}{2}, t \right)$$

Equation 3.4 Equations to find the flows of the cohesive sediment fractions between the water column and the bed

Where $E^{(1)}$ is the erosion flow (Kg/m² s), $M^{(1)}$ is the erosion parameter defined by the user (Kg/m² s), $D^{(1)}$ is the flow of deposition (Kg/m² s), $c_b^{(1)}$ is the average concentration for a sediment fraction in the computational layer near the bottom, and $S(\tau_{cw}, \tau_{cr,e}^{(1)})$ y $S(\tau_{cw}, \tau_{cr,d}^{(1)})$, they are functions of erosion and deposition respectively, defined by the following expressions (see Equation 3.5):

	ENVIRONMENTAL LICENSE MODIFICATION FOR THE CONSTRUCTION AND OPERATION PROJECT OF A PORT TERMINAL OF SOLID BULK CARGOES IN THE MUNICIPALITY OF TURBO	
	PROJECT DESCRIPTION	Page 110 of 165
	GAT-391-15-CA-AM-PIO-01	Revision:

$$S(\tau_{cw}, \tau_{cr,e}^{(1)}) = \begin{cases} \left(\frac{\tau_{cw}}{\tau_{cr,e}^{(1)}} - 1 \right) & \tau_{cw} > \tau_{cr,e}^{(1)} \\ 0 & \tau_{cw} \leq \tau_{cr,e}^{(1)} \end{cases}$$

$$S(\tau_{cw}, \tau_{cr,d}^{(1)}) = \begin{cases} \left(1 - \frac{\tau_{cw}}{\tau_{cr,d}^{(1)}} \right) & \tau_{cw} < \tau_{cr,d}^{(1)} \\ 0 & \tau_{cw} \geq \tau_{cr,d}^{(1)} \end{cases}$$

Equation 3.5 Equations to define the functions of erosion (left) and deposition (right)

Where τ_{cw} is the maximum tangential stress in the background due to currents and waves, $\tau_{cr,e}^{(1)}$ is the critical erosion tangential stress that is defined by the user (N/m²) y $\tau_{cr,d}^{(1)}$ is the critical tangential deposition voltage that is defined by the user (N/m²).

The erosion-deposition fluxes in the model, between the water column and the bottom, are calculated in the computational layer closest to the bottom.



Non-cohesive sediment

For the case of non-cohesive sediment, the sedimentation rate for sediment fraction is obtained according to the method of Van Rijn²⁵, depending on the diameter of the sediment in suspension, by means of the expressions (see Equation 3.6):

$$w_{s,0}^{(1)} = \begin{cases} \frac{(s^{(1)} - 1)gD_s^{(1)2}}{18\nu}, & 65 \mu m < D_s \leq 100 \mu m \\ \frac{10\nu}{D_s} \left(\sqrt{1 + \frac{0.01(s^{(1)} - 1)gD_s^{(1)3}}{\nu^2}} - 1 \right), & 100 \mu m < D_s \leq 1000 \mu m \\ 1.1\sqrt{(s^{(1)} - 1)gD_s^{(1)}}, & 1000 \mu m < D_s \end{cases}$$

Equation 3.6 Equation for sedimentation velocity for sediment fraction

²⁵ Van Rijn, L.C. Principles of Sediment Transport in Rivers, Estuaries and Coastal Seas. Aqua Publications, The Netherlands. 1993.

	ENVIRONMENTAL LICENSE MODIFICATION FOR THE CONSTRUCTION AND OPERATION PROJECT OF A PORT TERMINAL OF SOLID BULK CARGOES IN THE MUNICIPALITY OF TURBO	
	PROJECT DESCRIPTION	Page 111 of 165
	GAT-391-15-CA-AM-PIO-01	Revision:

Where $s^{(1)}$ is the relative density of the sediment fraction (l), $D_s^{(1)}$ is the representative diameter of the sediment fraction (l) y ν is the coefficient of kinematic viscosity of water (m²/s).

In the dispersion of non-cohesive sediment, the Delft3D model uses a horizontal diffusion coefficient equal to the one used to obtain the distribution of salinity in the bay (see salinity component). The vertical diffusion coefficient for sediments is obtained by the following expression (see Equation 3.7):

$$\varepsilon_s^{(1)} = \beta^{(1)} \varepsilon_f^{(1)}$$

Equation 3.7 Equation to obtain the vertical diffusion coefficient for the sediments

Where $\varepsilon_s^{(1)}$ is the vertical diffusion coefficient for the sediment fraction (l), $\beta^{(1)}$ is the Van Rijn factor for the sediment fraction and $\varepsilon_f^{(1)}$ is the vertical swirl viscosity coefficient of the turbulence closure model. The Van Rijn factor always takes values between 1 and 1.5 and is calculated as (see Equation 3.8):

$$\beta^{(1)} = 1 + 2 \left(\frac{w_s^{(1)}}{u_{*,c}} \right)^2$$

Equation 3.8 Equation to calculate the Van Rijn factor

Where, $u_{*,c}$ is the tangential tension in the bed due to currents.

For a more detailed description of this model, the reader is advised to consult the manual: "Delft3D-FLOW_User_Manual"²⁶.



Starting data and hypothesis

Next, the starting data and assumptions used in the simulations are indicated.

Characteristics of the dredging process

In relation to the dredging of Puerto Bahía Colombia de Urabá, the following information has been used:

²⁶ Available on internet: < <http://oss.deltares.nl/web/delft3d/manuals>>.

	ENVIRONMENTAL LICENSE MODIFICATION FOR THE CONSTRUCTION AND OPERATION PROJECT OF A PORT TERMINAL OF SOLID BULK CARGOES IN THE MUNICIPALITY OF TURBO	
	PROJECT DESCRIPTION	Page 112 of 165
	GAT-391-15-CA-AM-PIO-01	Revision:

- The dredging flow is 1.1 m³ / s with 30% solids, generating a solid dredging volume of 0.33 m³ /s.
- The volume of the barge vessel is 12,000 m³.
- In the hopper, 30% of the total accumulated volume corresponds to the fine material generated in the dredging process.
- The dump considered for the simulation is the one located at 4.1 km from the dredging area.
- The time it takes the dredger to go to the dump, unload and return to the dredging area was estimated in 1 hour.
- The target level to be reached in the dredging area is 16.7 m.

In turn, for the modeling of the dredging process, the following hypotheses have been adopted:

- Dredging is carried out continuously, that is, continuously until the target level is reached in the entire dredging area.
- The volume from which losses begin to be generated in the hopper (overflow) is 9600 m³ ²⁷. From this volume and, until the hopper is filled, a surface loss due to overflow of fines of 5% of the incoming solid flow is generated.
- The fines generated in the dredging process have been considered as fine silts with a density of 1800 kg / m³, not taking into account the possible flocculation of them. In this way, it is on the side of safety when analyzing the dispersion of fine dredging material.
- The critical tangential stresses of erosion and deposition have been considered equal to 1 N / m² and 0.25 N / m², respectively²⁸.

Solids introduced by León and Atrato rivers

The average concentration of solids, contributed by León and Atrato rivers, has been obtained from the modeling of sediment transport in the Golfo de Urabá, Colombia²⁹. Table Num. 3.17 shows the concentration of suspended solids introduced in the dry, transition and wet seasons.

²⁷ IH Cantabria. INNODRAVAL Project. Phase 2: Development of Predictive Tools for the Estimation of Environmental Effects. INNODRAVAL Project (IPT-310000-2010-17). 2013

²⁸ Wu, Y., Falconer, R.A., Lin, B. Modelling trace metal concentration distributions in estuarine waters. *En: Estuarine, Coastal and Shelf Science*. 2005. vol. 64, p. 699 – 709.

²⁹ Velásquez, L. Modeling of sediment transport in the Golfo of Urabá, Colombia. Degree work to opt for the title of magister in earth sciences. EAFIT 2013.



	ENVIRONMENTAL LICENSE MODIFICATION FOR THE CONSTRUCTION AND OPERATION PROJECT OF A PORT TERMINAL OF SOLID BULK CARGOES IN THE MUNICIPALITY OF TURBO	
	PROJECT DESCRIPTION	Page 113 of 165
	GAT-391-15-CA-AM-PIO-01	Revision:

Table Num. 3.17. Solid flow introduced by León and Atrato rivers to Golfo de Urabá

River or Arm	Liquid flow rate (m ³ / s)	Solid flow (kg / m ³)
Rio León	250	0.12
Leoncito	776	0.1
Matungo	981	0.086
Roto	3200	0.069
Tarena	34	0.087

Source: Velásquez, 2013³⁰

For the realization of the simulations and taking into account the information provided by AQUA & TERRA Consultores Asociados S.A.S, the material introduced by the river León and the Atrato River has been defined as fine silts with a density of 1800 kg / m³.

Tides

To introduce the tidal boundary conditions, the harmonic components provided by the TPXO model have been used, which is a reverse tidal model that assimilates the sea level information derived from the observations of the TOPEX/Poseidon sensor.



Currently, the TPXO model, which is one of the most accurate global tide models, provides four semidiurnal harmonic components (M₂, S₂, N₂, K₂), four diurnal components (K₁, O₁, P₁, Q₁), two long-period components (M_f and M_m) and three of short period (M₄, M_{n4}, M_{s4}), in a mesh with global coverage of 1440 x 721 points with 0.25° of spatial resolution. In this study we have used the most recent database, TPXO7.2.

Figure Num. 3.50 shows the location of the TPXO point closest to the study area and on Figure Num. 3.51 you can see the series of the astronomical tide level obtained with the harmonic components at that point, for the first and second semester of the year.

Table Num. 3.18 Tidal harmonic components, obtained from TPXO

Component	Frequency	Period (hr)	Amplitude (m)	Phase (°)
m ₂	28.984101	12.42	0.0693	151.22
s ₂	30	12	0.0168	12.35
n ₂	28.43973	12.66	0.0255	120.74
k ₂	30.082137	11.97	0.0052	0.04
k ₁	15.041069	23.94	0.0937	239.45

³⁰ Velásquez, L. Modeling of sediment transport in the Golfo of Urabá, Colombia. Degree work to opt for the title of magister in earth sciences. EAFIT 2013

	ENVIRONMENTAL LICENSE MODIFICATION FOR THE CONSTRUCTION AND OPERATION PROJECT OF A PORT TERMINAL OF SOLID BULK CARGOES IN THE MUNICIPALITY OF TURBO		
	PROJECT DESCRIPTION	Page 114 of 165	
	GAT-391-15-CA-AM-PIO-01	Revision:	

Component	Frequency	Period (hr)	Amplitude (m)	Phase (°)
o1	13.943036	25.8	0.0576	240.29
p1	14.958931	24.07	0.029	244.4
q1	13.398661	26.87	0.0082	236.03
mf	1.098033	328	0.0168	356.53
mm	0.544375	661	0.0081	353.33
m4	57.96821	6.2103	0.0019	151.72
ms4	58.984104	6.1033	0.005	340.28
mn4	57.423	6.2393	0.0018	193.14

Source: Aqua&Terra Consultores Asociados S.A.S, 2014

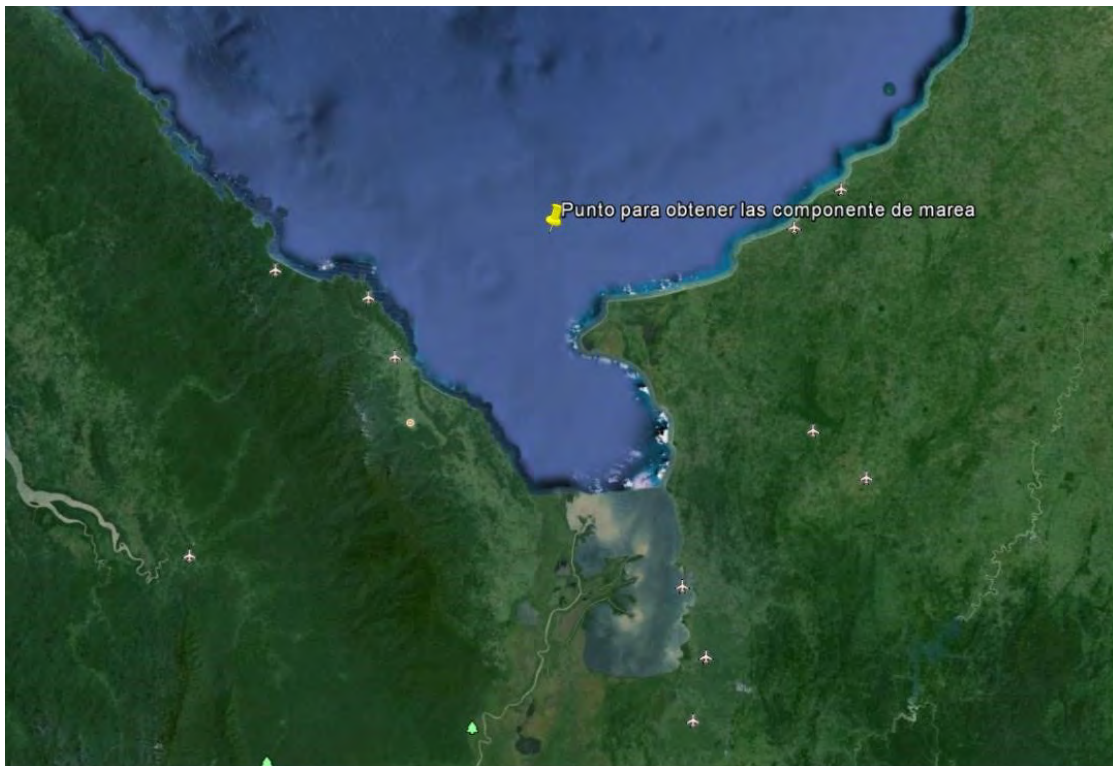



Figure Num. 3.50. Location of the point where the harmonic components of the TPXO were obtained

Source: Aqua&Terra Consultores Asociados S.A.S, 2015.

	ENVIRONMENTAL LICENSE MODIFICATION FOR THE CONSTRUCTION AND OPERATION PROJECT OF A PORT TERMINAL OF SOLID BULK CARGOES IN THE MUNICIPALITY OF TURBO	
	PROJECT DESCRIPTION	Page 115 of 165
	GAT-391-15-CA-AM-PIO-01	Revision:

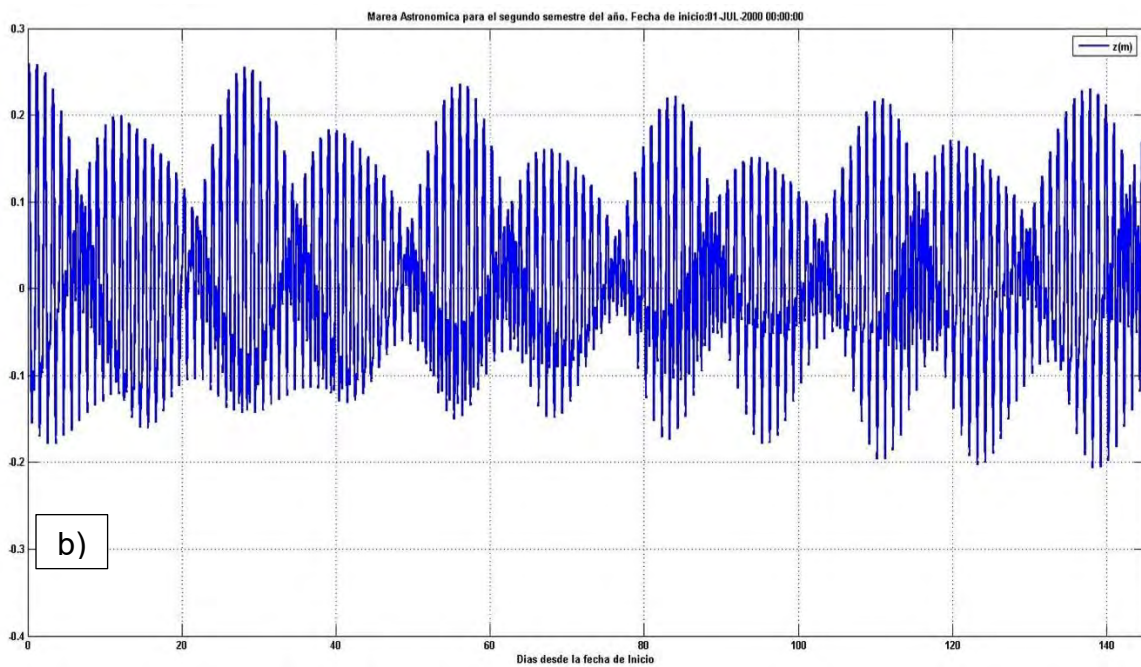
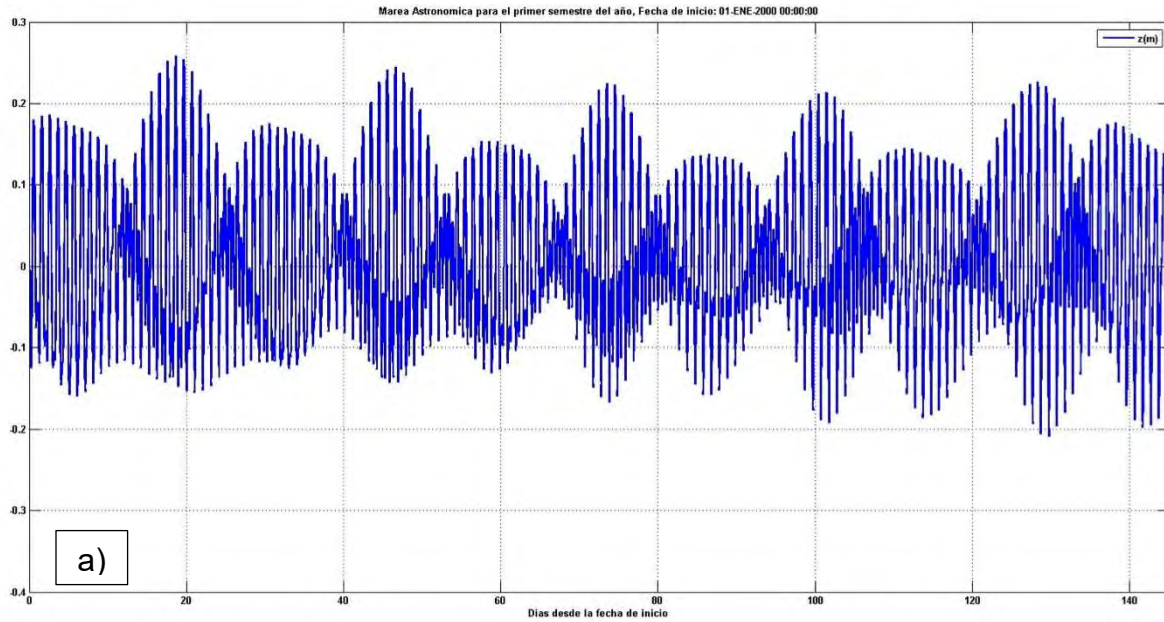



Figure Num. 3.51. Series of astronomical tide for the point to the outskirts of the Golfo de Urabá. a) Series for the first semester of the year and b) series for the second semester of the year.

Source: Aqua&Terra Consultores Asociados S.A.S, 2015.

	ENVIRONMENTAL LICENSE MODIFICATION FOR THE CONSTRUCTION AND OPERATION PROJECT OF A PORT TERMINAL OF SOLID BULK CARGOES IN THE MUNICIPALITY OF TURBO	
	PROJECT DESCRIPTION	Page 116 of 165
	GAT-391-15-CA-AM-PIO-01	Revision:

Winds

Figure Num. 3.52 presents the multi-year average winds in direction and frequency according to the speed in m/s of the Turbo station between January 1949 and May 1984. The figure shows the direction from where, the winds reach the point where the measuring station is located.

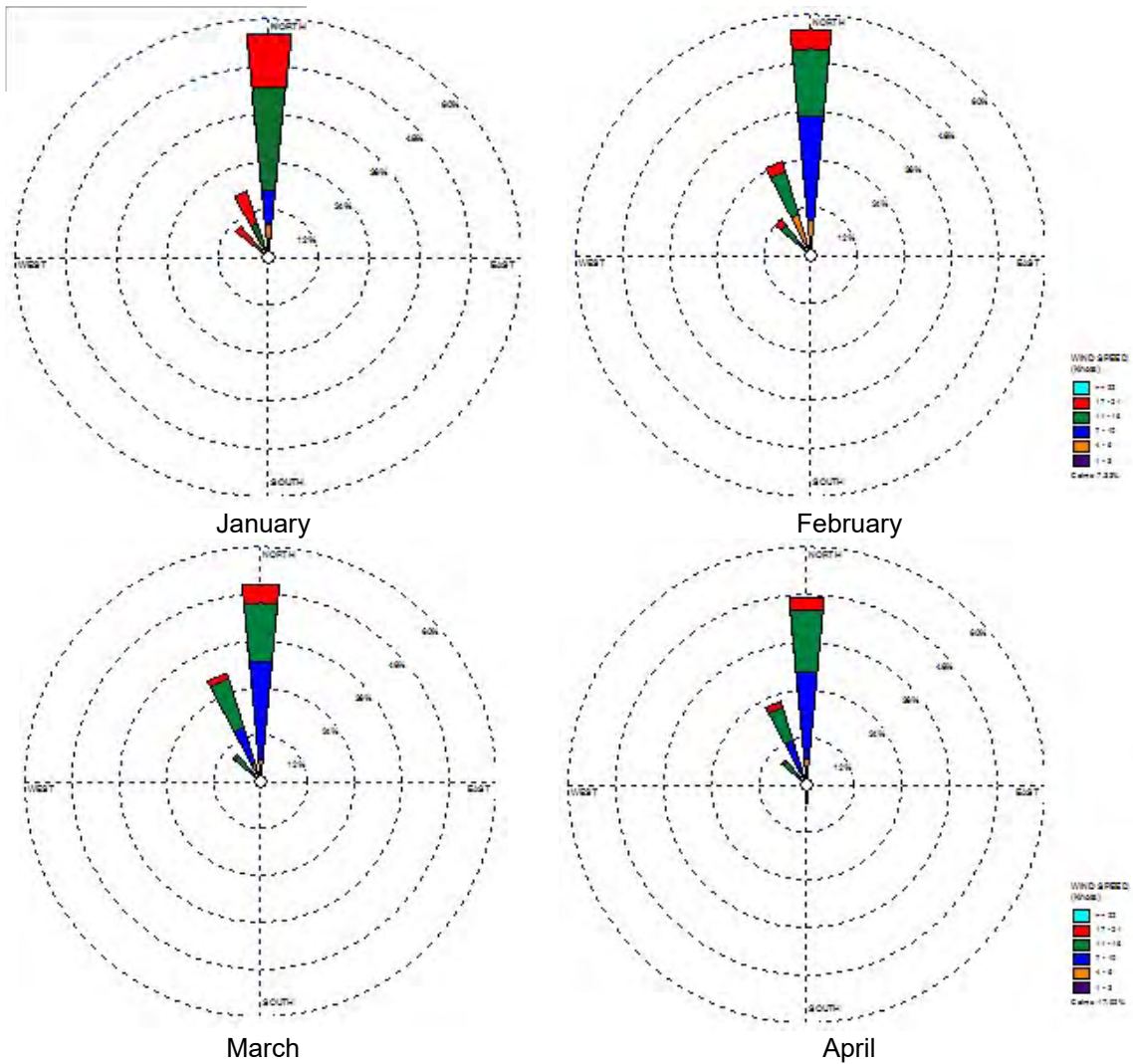



ENVIRONMENTAL LICENSE MODIFICATION FOR THE
CONSTRUCTION AND OPERATION PROJECT OF A PORT
TERMINAL OF SOLID BULK CARGOES IN THE
MUNICIPALITY OF TURBO



PROJECT DESCRIPTION

Page 117 of 165

GAT-391-15-CA-AM-PIO-01

Revision:

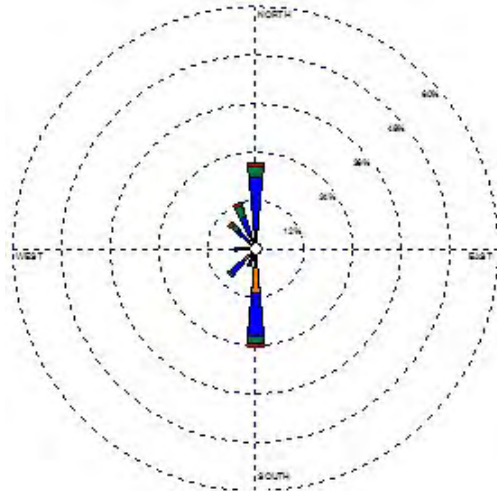

May

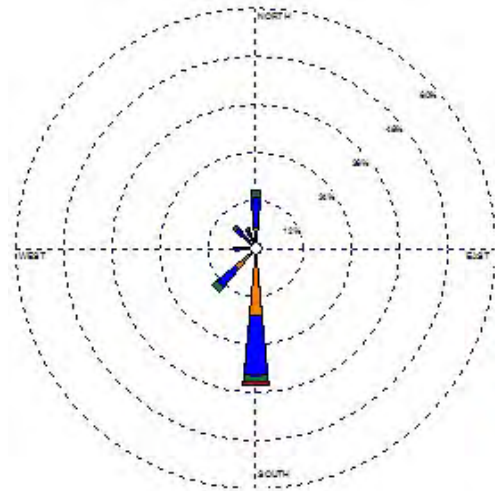

June

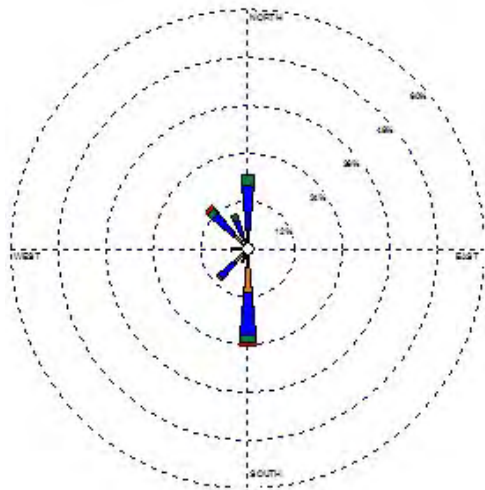

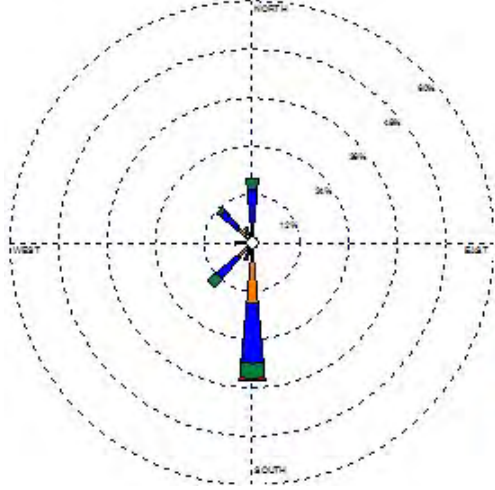

July



August

WIND SPEED
(Knots)
9-10
7-8
5-6
3-4
1-2
Data 18.7%

WIND SPEED
(Knots)
9-10
7-8
5-6
3-4
1-2
Data 18.8%

	ENVIRONMENTAL LICENSE MODIFICATION FOR THE CONSTRUCTION AND OPERATION PROJECT OF A PORT TERMINAL OF SOLID BULK CARGOES IN THE MUNICIPALITY OF TURBO	
	PROJECT DESCRIPTION	Page 118 of 165
	GAT-391-15-CA-AM-PIO-01	Revision:

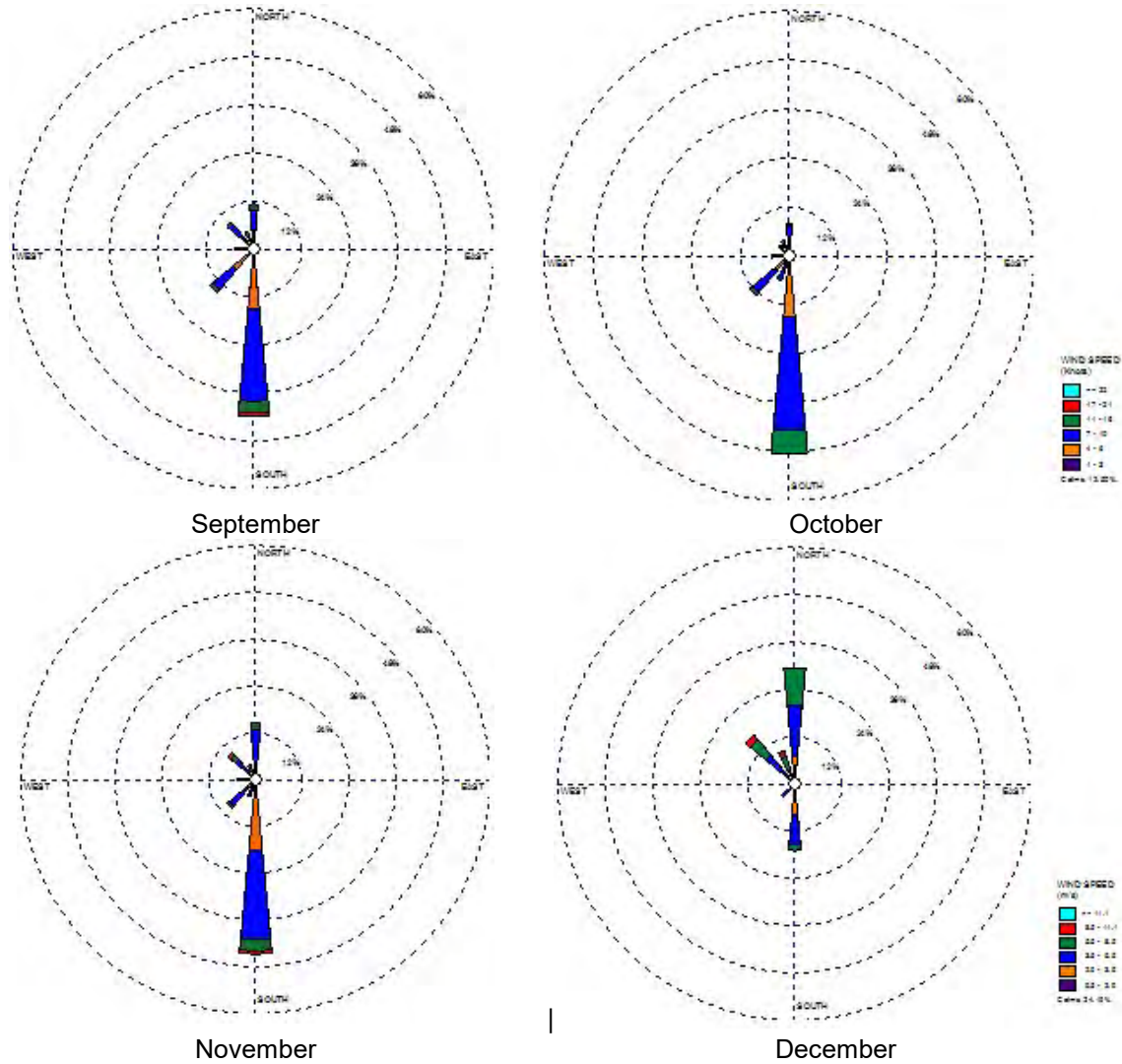



Figure Num. 3.52. Annual Wind season of Turbo station.
Source: Aqua&Terra Consultores Asociados S.A.S, 2015.

From the previous figure it can be seen that for the months of January, February, March and April, the persistent winds are those that come from the north, with magnitudes that can reach 11m / s.

In the month of May you can see a transition of the winds, becoming the winds that come from the south the most persistent, which extend until November. In December the north winds are again more persistent in the area.

Selection of cases for modeling dredging and material dumping

	ENVIRONMENTAL LICENSE MODIFICATION FOR THE CONSTRUCTION AND OPERATION PROJECT OF A PORT TERMINAL OF SOLID BULK CARGOES IN THE MUNICIPALITY OF TURBO	
	PROJECT DESCRIPTION	Page 119 of 165
	GAT-391-15-CA-AM-PIO-01	Revision:

According to the information and existing reports in the study area, we proceeded to select the cases for the modeling of the dredging and the dumping of material. In the Table Num. 3.19 the two modelling cases are shown, because the duration of the dredging was estimated at 120 days, it was decided to carry out the simulation for the two semesters of the year.

The contour data used for modeling are also shown in the following table

Table Num. 3.19 Selection of cases



TIME	YEAR	CONTOUR CONDITIONS				ATMOSPHERE
		Level (m)	River	Flow ⁽¹⁾ (m ³ /s)	Sediment concentration (kg/m ³)	Winds
First Semester	2000	TPXO7.2 (0,25°/15 min)	León	250	0.12	Turbo Station
			Leoncito	776	0.1	
			Matungo	981	0.086	
			Roto	3200	0.069	
			Tarena	34	0.087	
Second Semester	2000		León	250	0.12	
			Leoncito	776	0.1	
			Matungo	981	0.086	
			Roto	3200	0.069	
			Tarena	34	0.087	

Model configuration in Golfo de Urabá

To obtain the hydrodynamics and therefore estimate the dispersion of the sediments in the dredging and in the dumping of material, the three-dimensional model has been applied Delft3D.

The main characteristics of the numerical simulation are the following:

- **Numerical mesh:** a numerical mesh has been constructed for each of the two situations analyzed: first and second semester. The horizontal resolution of the mesh is 200 m in most of the domain and 100 m in the area of interest, and in vertical has 1 level. The meshes cover the extension covered by the bathymetries shown in Figure Num. 3.46.
- **Boundary conditions:** As astronomical boundary conditions the astronomical tide obtained from the TPXO model has been introduced for each of the modeled times.



	ENVIRONMENTAL LICENSE MODIFICATION FOR THE CONSTRUCTION AND OPERATION PROJECT OF A PORT TERMINAL OF SOLID BULK CARGOES IN THE MUNICIPALITY OF TURBO	
	PROJECT DESCRIPTION	Page 120 of 165
	GAT-391-15-CA-AM-PIO-01	Revision:

- Atmospheric forcing: wind time information obtained from the Turbo station has been imposed.
- Base Friction: has been a parameter that has been adjusted to obtain the best adjustment with the levels measured by the tide gauge of the CIOH (Center for Oceanographic and Hydrographic Research of the Caribbean). As a result, a mean value of $45 \text{ m}^{1/2}/\text{s}$ Chezy coefficient was used
- As a value for the horizontal swirl viscosity and the diffusion coefficient, $1.5 \text{ m}^{1/2}/\text{s}$ has been used. These values have been estimated based on cell size and currents typical of the study area. The vertical swirl viscosity coefficient was considered two orders of magnitude smaller than the horizontal³¹.

3.3.2.1 Scattering Halo

To characterize the total suspended solids (SST) of the water column, the Quality Monitoring Network of maritime and coastal waters of Colombia (REDCAM) has been used. In such a way that for the Bay of Colombia there is a series of stations that is presented in Figure Num. 3.42.

³¹ Bloss, S., Lehfeltd, R., Patterson, J.C. (1988). "Modelling turbulent transport in stratified estuary". Journal of Hydraulic Engineering, Vol. 114, N.º 9, pp. 1115 – 1133.

	ENVIRONMENTAL LICENSE MODIFICATION FOR THE CONSTRUCTION AND OPERATION PROJECT OF A PORT TERMINAL OF SOLID BULK CARGOES IN THE MUNICIPALITY OF TURBO	
	PROJECT DESCRIPTION	Page 121 of 165
	GAT-391-15-CA-AM-PIO-01	Revision:

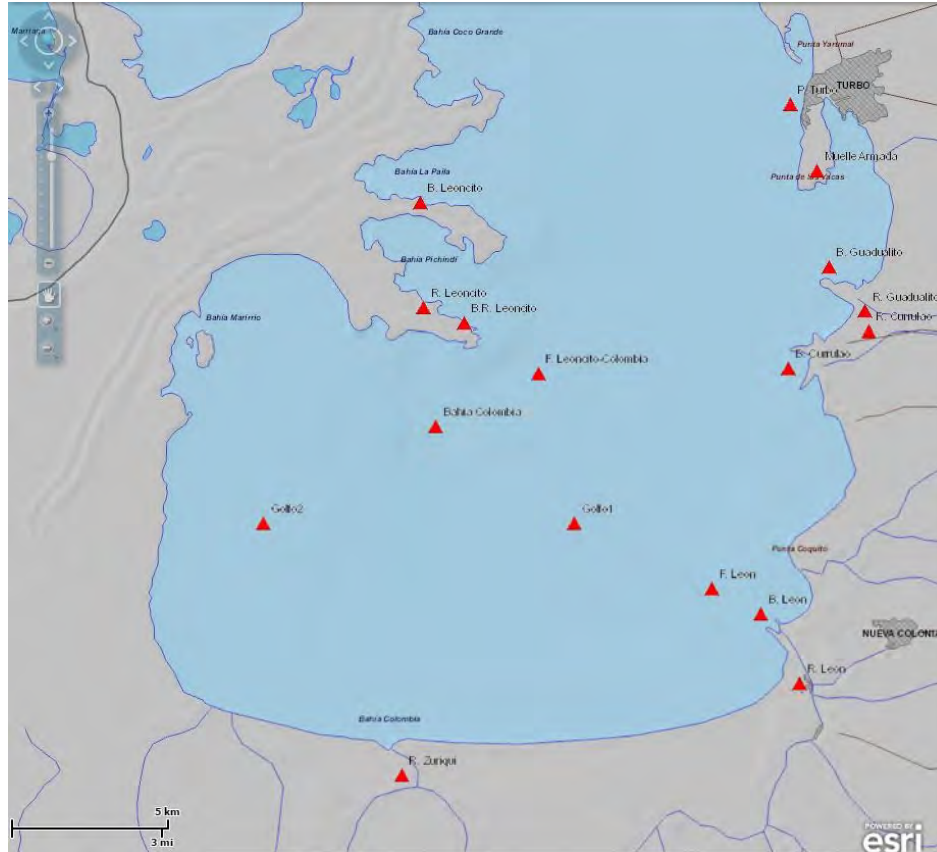

Figure Num. 3.53. Location of REDCAM stations
Source: http://gis.invemar.org.co/redcam_colombia/



To characterize the study area, we have taken as reference the stations Bahía Colombia, Leoncito – Colombia front, Facing The León Riiver. It is clarified that the Golfo 1 and Golfo 2 stations do not have SST information.

Table Num. 3.20. Historical values of Total Suspended Solids in Bahía Colombia (mg/l)

Station Cod.	Station	Average	Maximum
C05003002	(S) (in front of) Km after The León Riiver - DGI015	1641.70	2485.0
C05003021	(S) F. Leoncito - B. Colombia-Fondeadero-DGI030	49.15	84
C05003046	(S) Bahía Colombia	72.00	246

Source: <http://siam.invemar.org.co/siam/redcam/estadisticas/index.jsp#nivel31>

Considering the high variability of this component in the bay, the average values of the three stations have been averaged (see Table Num. 3.20), To determine the dispersion threshold in the bay, this average value is 587 mg/l.

	ENVIRONMENTAL LICENSE MODIFICATION FOR THE CONSTRUCTION AND OPERATION PROJECT OF A PORT TERMINAL OF SOLID BULK CARGOES IN THE MUNICIPALITY OF TURBO	
	PROJECT DESCRIPTION	Page 122 of 165
	GAT-391-15-CA-AM-PIO-01	Revision:

To determine the dispersion halo in the dredging and dump areas, the following criteria have been taken as reference:

- The concentration threshold has been defined by 587 mg/l.
- A dispersion model has been generated of all the phases that contemplate the dredging activity, corresponding to dredging and unloading in the dump, for 2 periods of the year; first and second semester.
- The distribution of cells in the dump is defined as 100 m per 100 m.
- It is defined as maximum concentration, the moment of unloading or dredging of the dredge in the configuration of cells of the dump (Figure Num. 3.54).

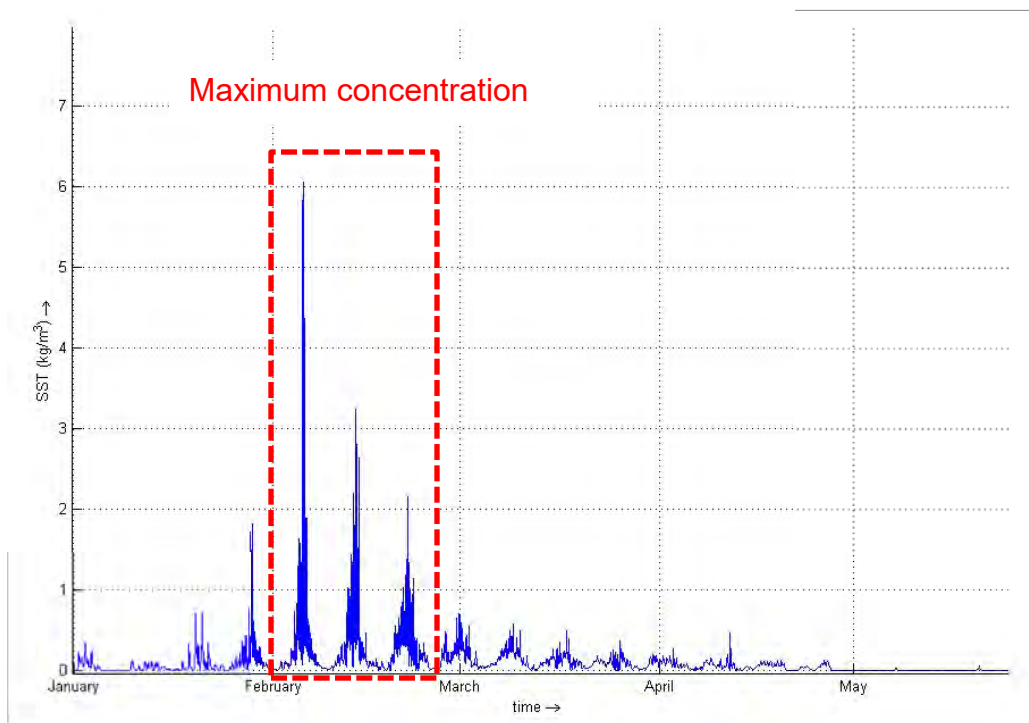



Figure Num. 3.54. Concentration of suspended solids for a discharge cell in the dump
Source: Aqua & Terra Consultores Asociados, 2015

Under the criteria presented above to determine the dispersion limit for this activity (Figure Num. 3.55), See below a sequence of figures for the maximum level of unload on the dump perimeter and thus determine the dispersion halo for the first half modeled.

FIRST SEMESTER

	ENVIRONMENTAL LICENSE MODIFICATION FOR THE CONSTRUCTION AND OPERATION PROJECT OF A PORT TERMINAL OF SOLID BULK CARGOES IN THE MUNICIPALITY OF TURBO	
	PROJECT DESCRIPTION	Page 123 of 165
	GAT-391-15-CA-AM-PIO-01	Revision:

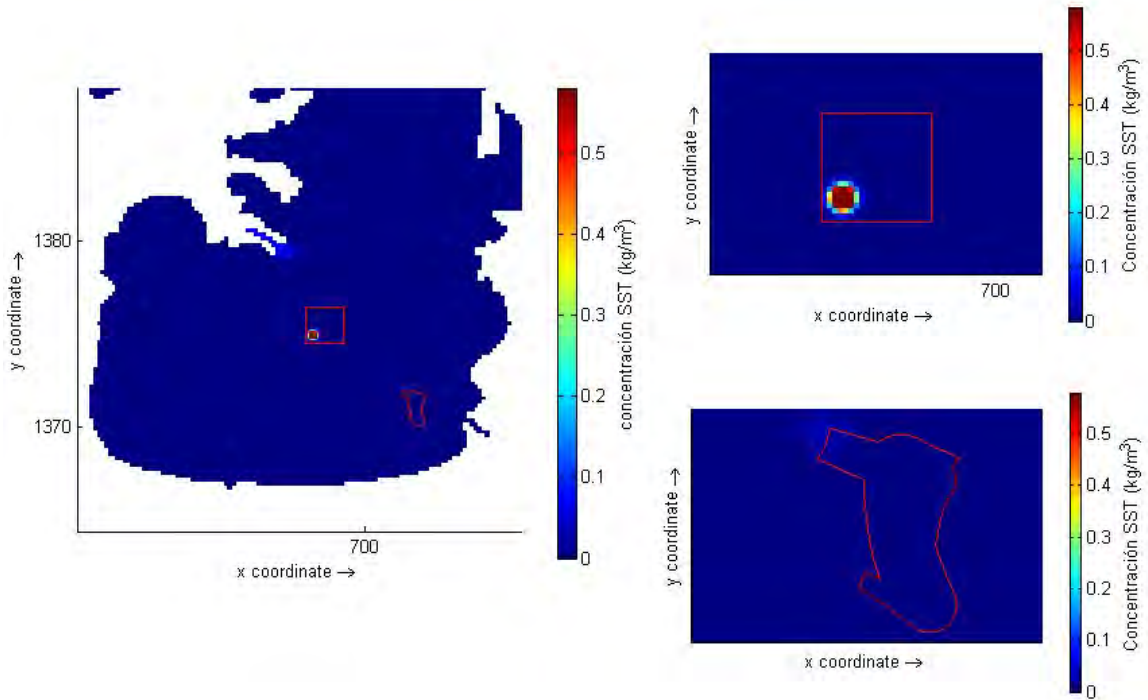

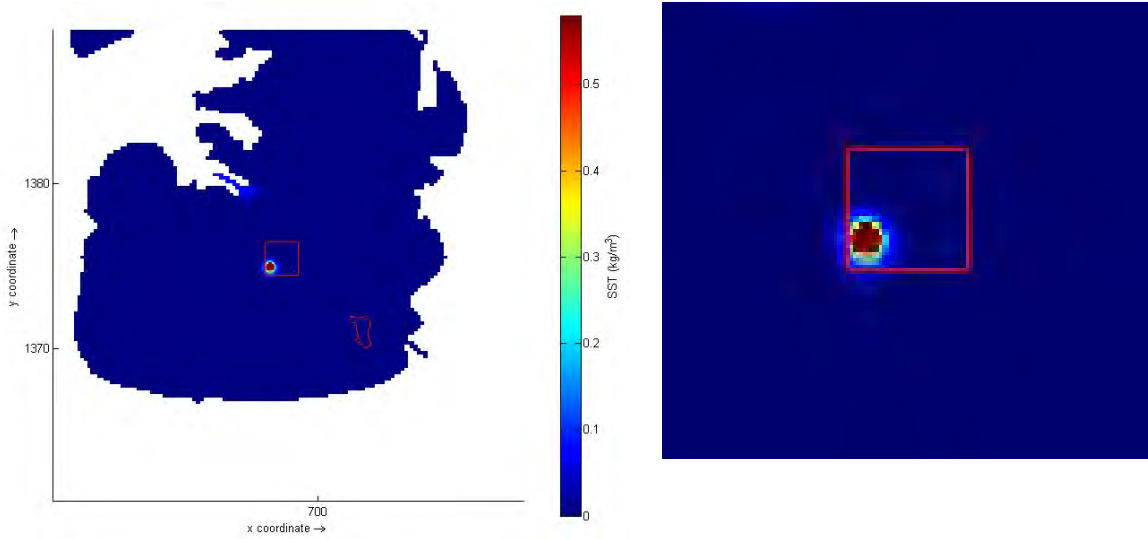
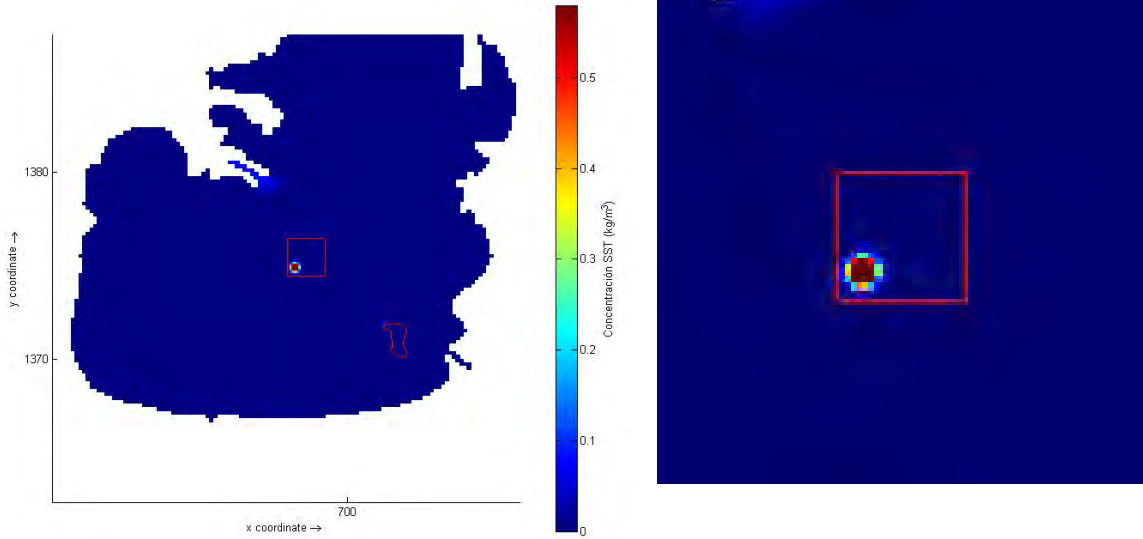

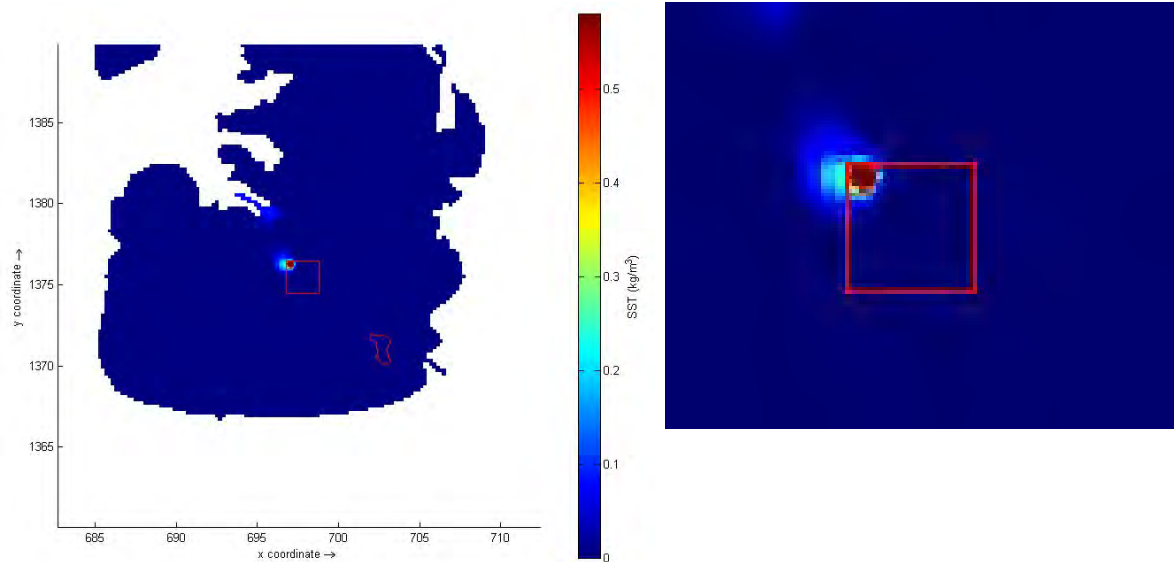
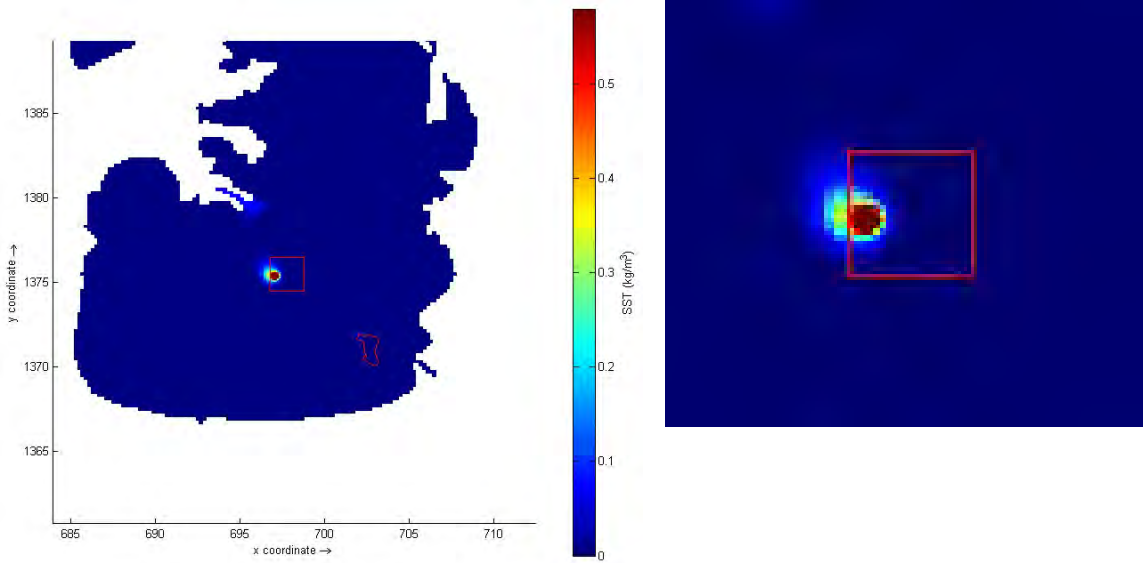



Figure Num. 3.55. Location of dredging area and dump
Source: Aqua & Terra Consultores Asociados, 2015

	ENVIRONMENTAL LICENSE MODIFICATION FOR THE CONSTRUCTION AND OPERATION PROJECT OF A PORT TERMINAL OF SOLID BULK CARGOES IN THE MUNICIPALITY OF TURBO	 aqua & terra
	PROJECT DESCRIPTION	Page 124 of 165
	GAT-391-15-CA-AM-PIO-01	Revision:





	ENVIRONMENTAL LICENSE MODIFICATION FOR THE CONSTRUCTION AND OPERATION PROJECT OF A PORT TERMINAL OF SOLID BULK CARGOES IN THE MUNICIPALITY OF TURBO	
	PROJECT DESCRIPTION	Page 125 of 165
	GAT-391-15-CA-AM-PIO-01	Revision:



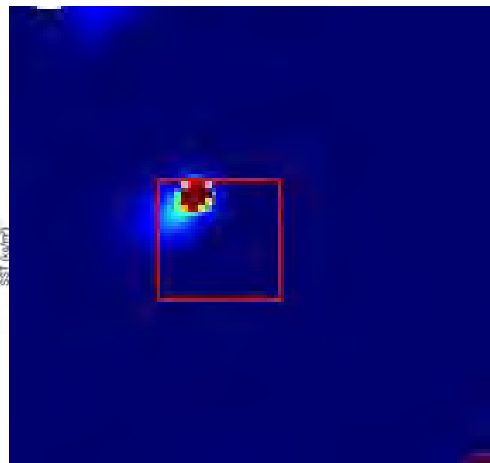
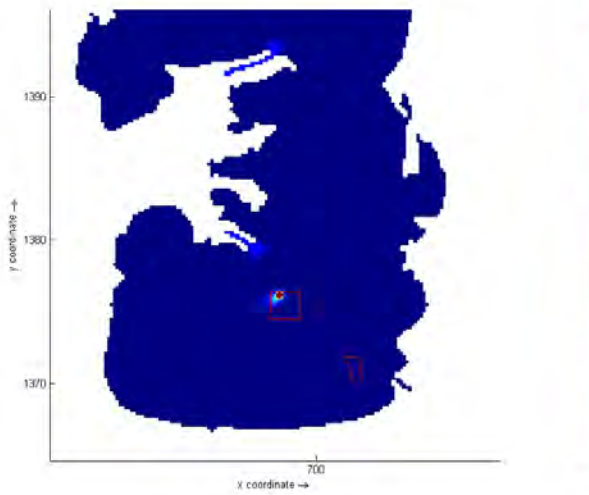
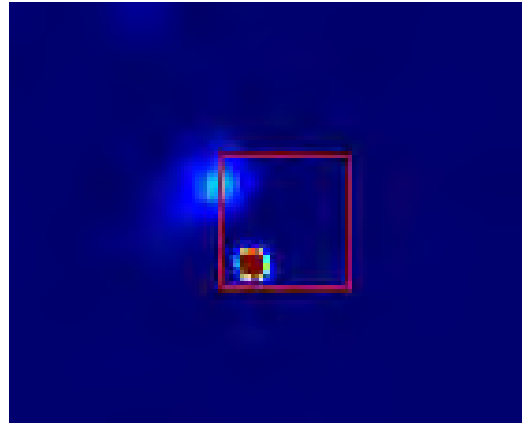
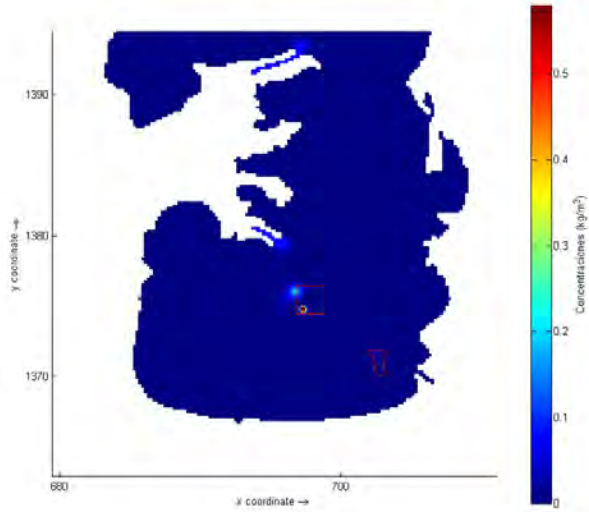

	<p align="center">ENVIRONMENTAL LICENSE MODIFICATION FOR THE CONSTRUCTION AND OPERATION PROJECT OF A PORT TERMINAL OF SOLID BULK CARGOES IN THE MUNICIPALITY OF TURBO</p>	
	<p align="center">PROJECT DESCRIPTION</p>	<p align="center">Page 126 of 165</p>
	<p align="center">GAT-391-15-CA-AM-PIO-01</p>	<p>Revision: <input type="text"/></p>



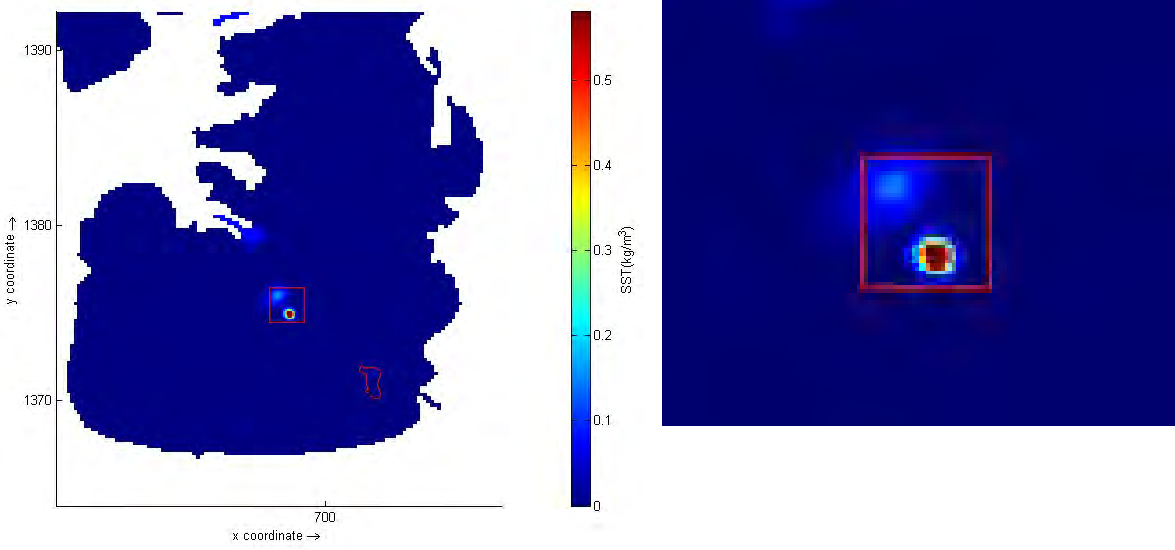
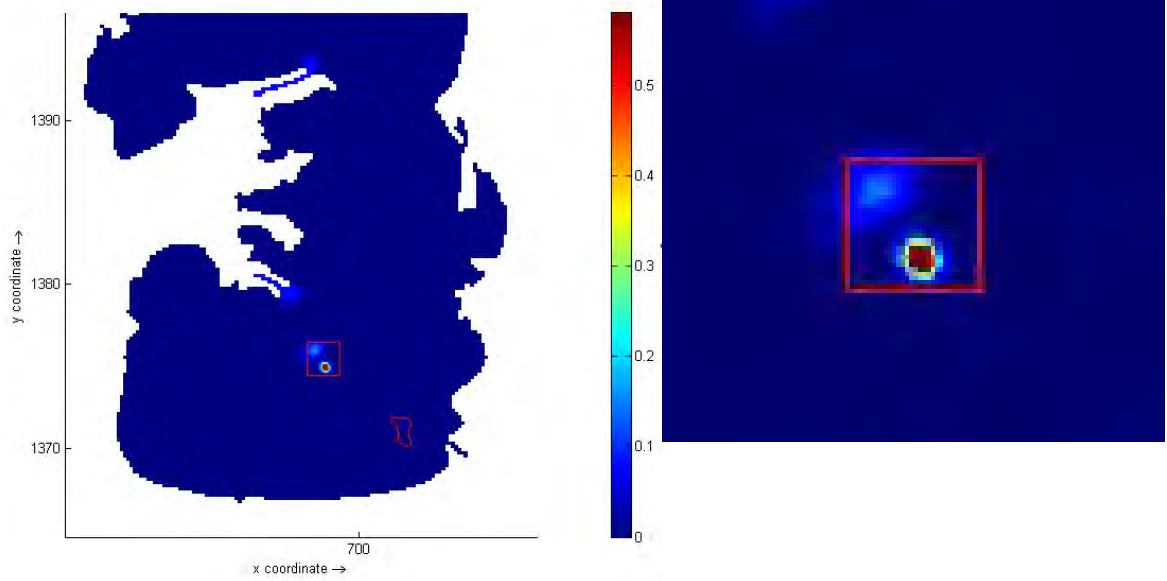

	ENVIRONMENTAL LICENSE MODIFICATION FOR THE CONSTRUCTION AND OPERATION PROJECT OF A PORT TERMINAL OF SOLID BULK CARGOES IN THE MUNICIPALITY OF TURBO	
	PROJECT DESCRIPTION	Page 127 of 165
	GAT-391-15-CA-AM-PIO-01	Revision:



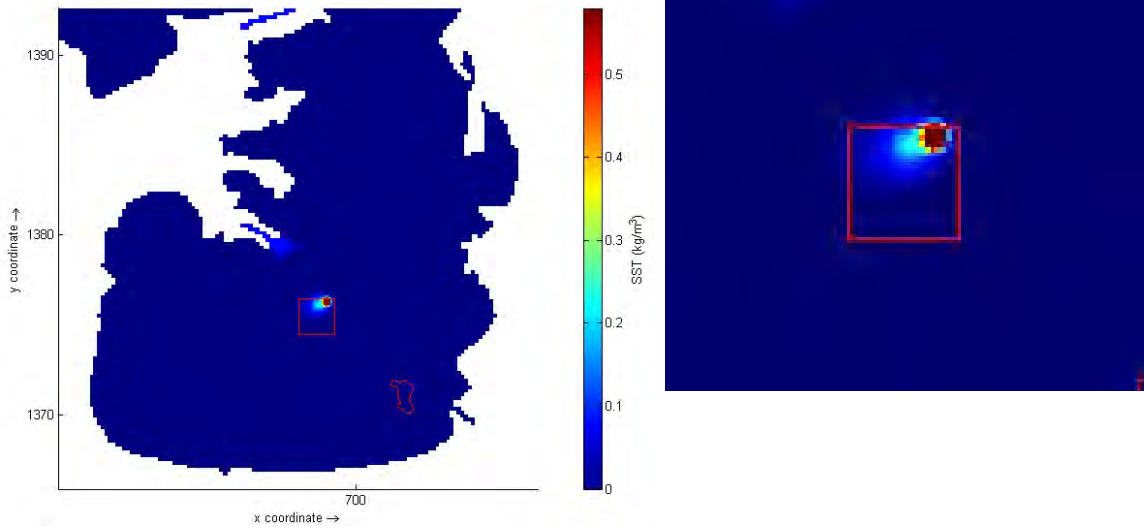
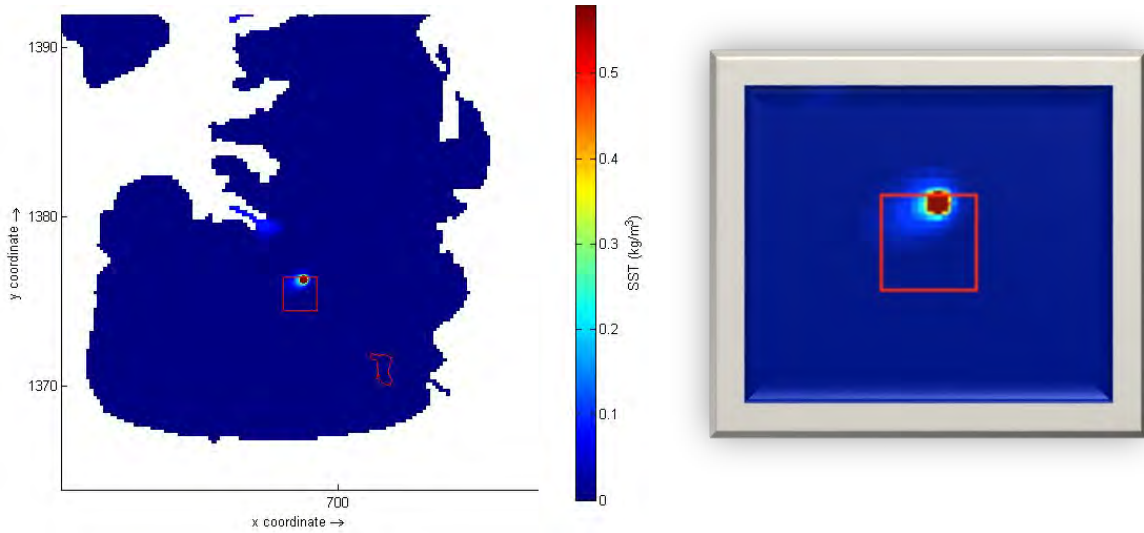

	ENVIRONMENTAL LICENSE MODIFICATION FOR THE CONSTRUCTION AND OPERATION PROJECT OF A PORT TERMINAL OF SOLID BULK CARGOES IN THE MUNICIPALITY OF TURBO	
	PROJECT DESCRIPTION	Page 128 of 165
	GAT-391-15-CA-AM-PIO-01	Revision:

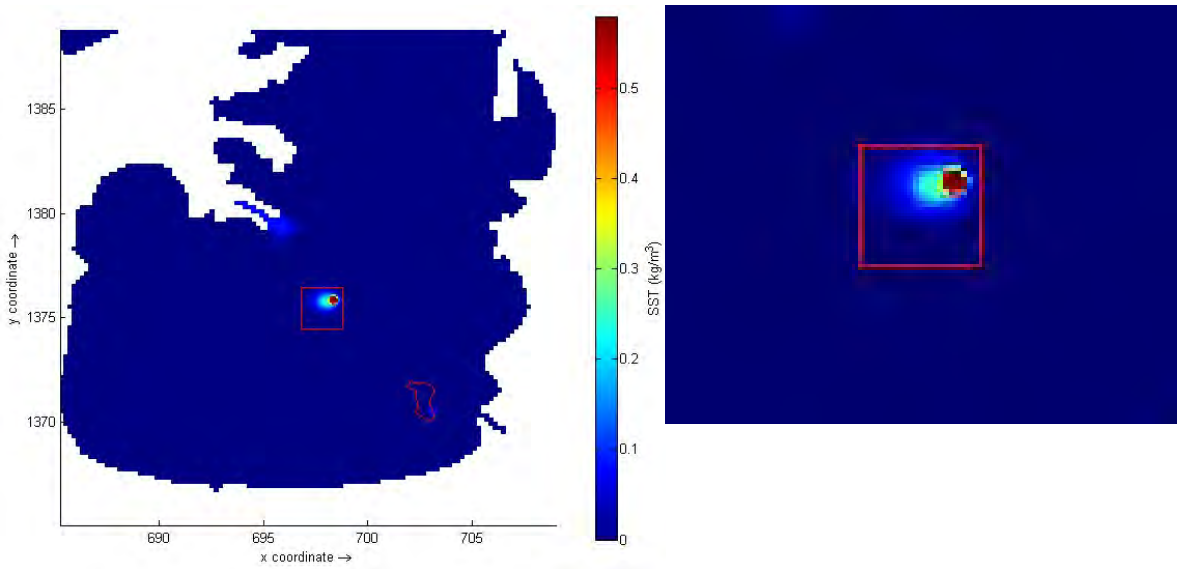
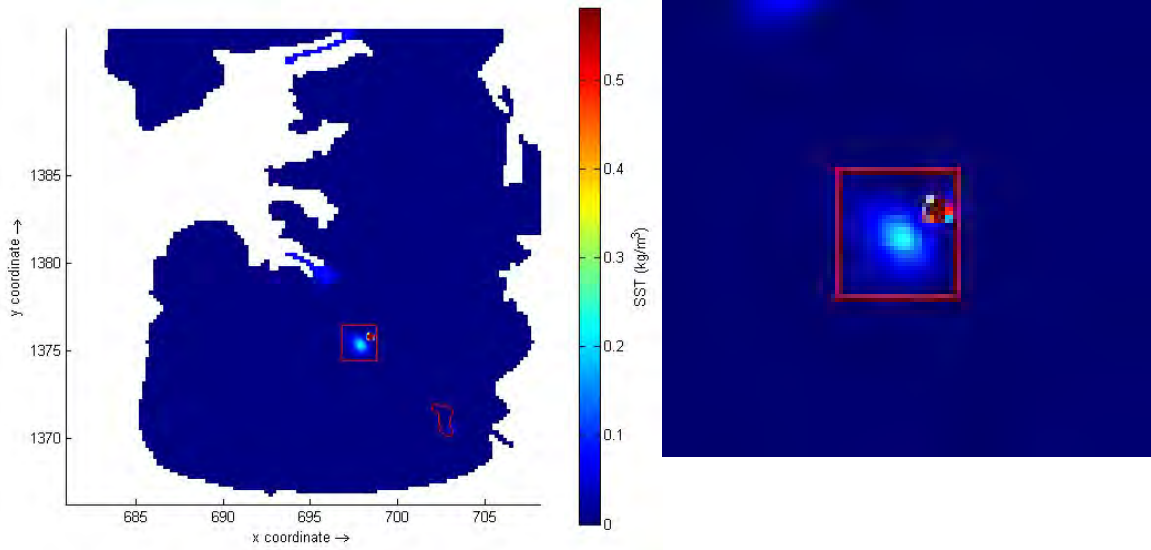

	<p align="center">ENVIRONMENTAL LICENSE MODIFICATION FOR THE CONSTRUCTION AND OPERATION PROJECT OF A PORT TERMINAL OF SOLID BULK CARGOES IN THE MUNICIPALITY OF TURBO</p>	
	<p align="center">PROJECT DESCRIPTION</p>	<p align="right">Page 129 of 165</p>
	<p align="center">GAT-391-15-CA-AM-PIO-01</p>	<p>Revision: <input type="text"/></p>



	ENVIRONMENTAL LICENSE MODIFICATION FOR THE CONSTRUCTION AND OPERATION PROJECT OF A PORT TERMINAL OF SOLID BULK CARGOES IN THE MUNICIPALITY OF TURBO	
	PROJECT DESCRIPTION	Page 130 of 165
	GAT-391-15-CA-AM-PIO-01	Revision:

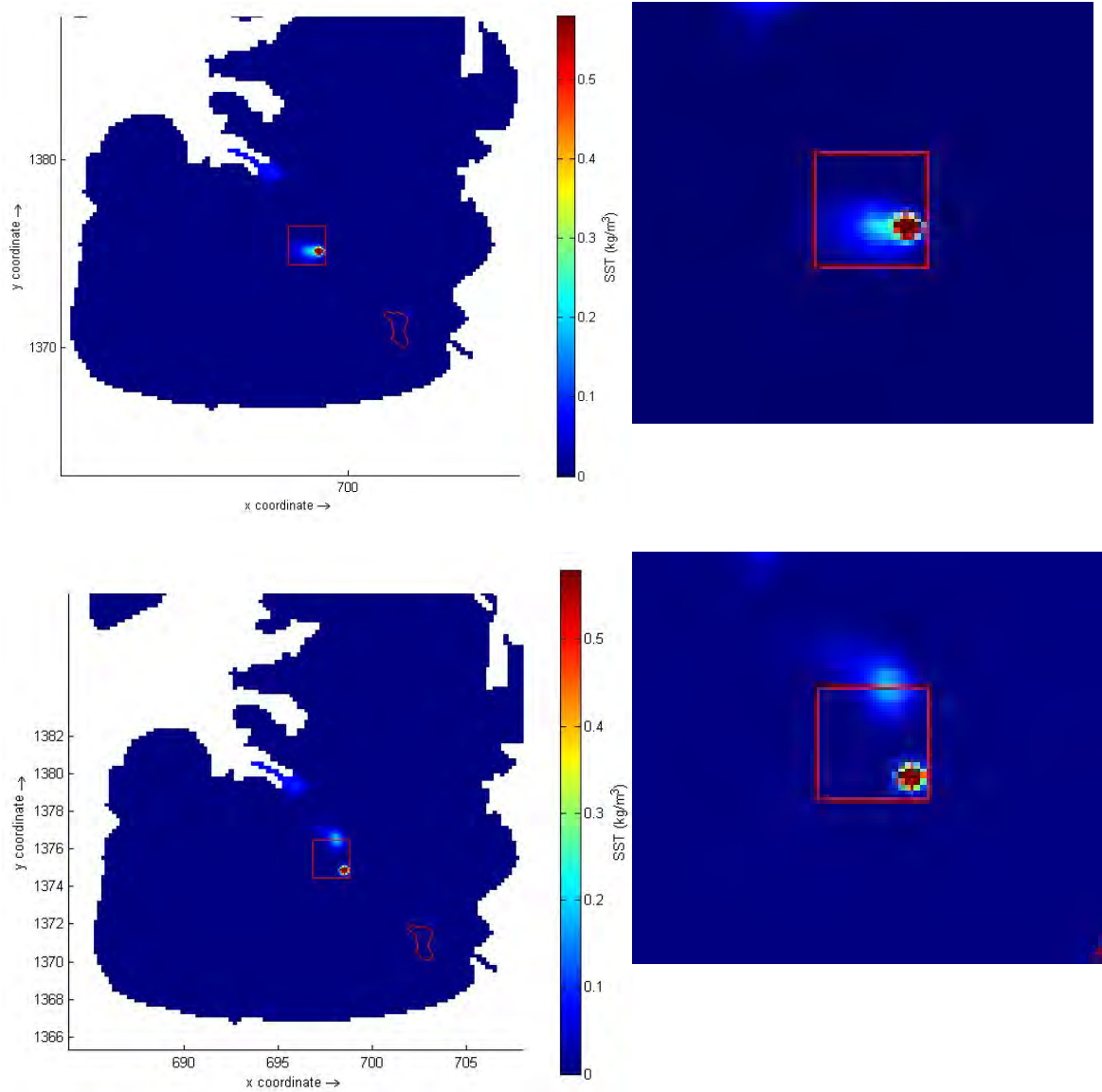

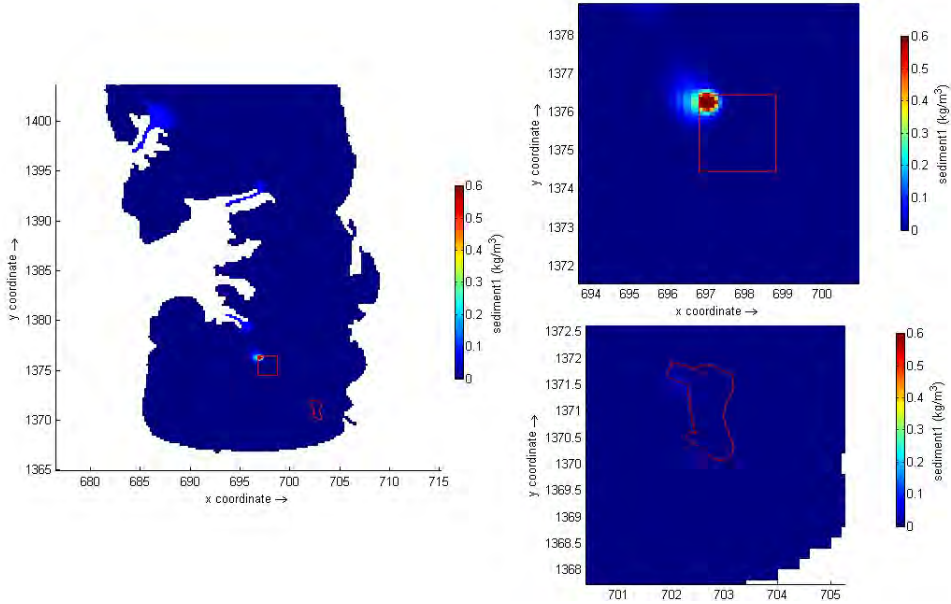

Figure Num. 3.56. Sequence of greater dispersion on the perimeter of the dump.
Source: Aqua & Terra Consultores Asociados, 2015

As evidenced by the disposal sequence of the dredged material in the dump, the dispersion does not exceed the limit of the area of influence of 2000 m by 2000 m, considering as a starting point a dump area of 1400 m by 1400 m internally in this area. It is important to note that the dispersion of the poured material dissipates in the water column in approximately 4 hours. To have a better approximation of the dispersion that the material has, then a series of figures is presented every hour minutes, which allows us to show this phenomenon.

	ENVIRONMENTAL LICENSE MODIFICATION FOR THE CONSTRUCTION AND OPERATION PROJECT OF A PORT TERMINAL OF SOLID BULK CARGOES IN THE MUNICIPALITY OF TURBO	
	PROJECT DESCRIPTION	Page 131 of 165
	GAT-391-15-CA-AM-PIO-01	Revision:





a. 08/Jan 13:30

study area area

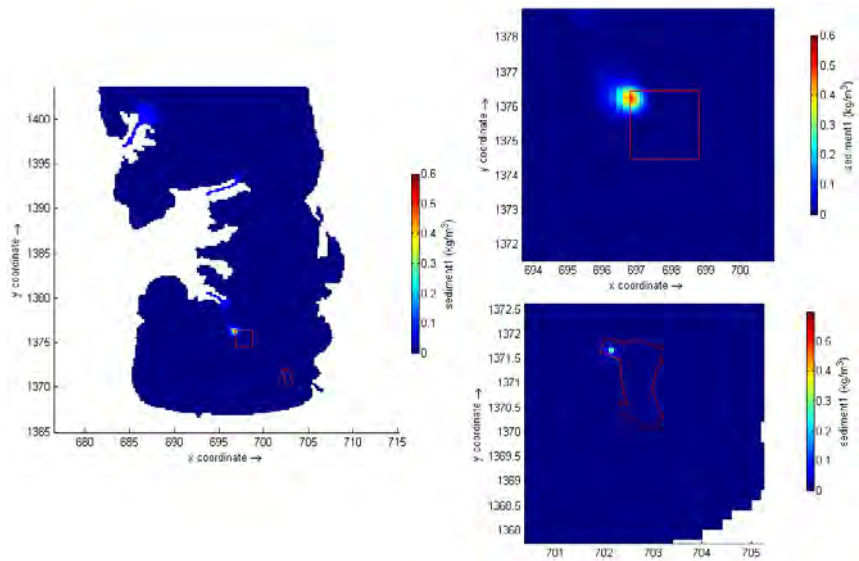
b. 08/Jan 16:30



c. 08/Jan 17:30

	ENVIRONMENTAL LICENSE MODIFICATION FOR THE CONSTRUCTION AND OPERATION PROJECT OF A PORT TERMINAL OF SOLID BULK CARGOES IN THE MUNICIPALITY OF TURBO	
	PROJECT DESCRIPTION	Page 132 of 165
	GAT-391-15-CA-AM-PIO-01	Revision:

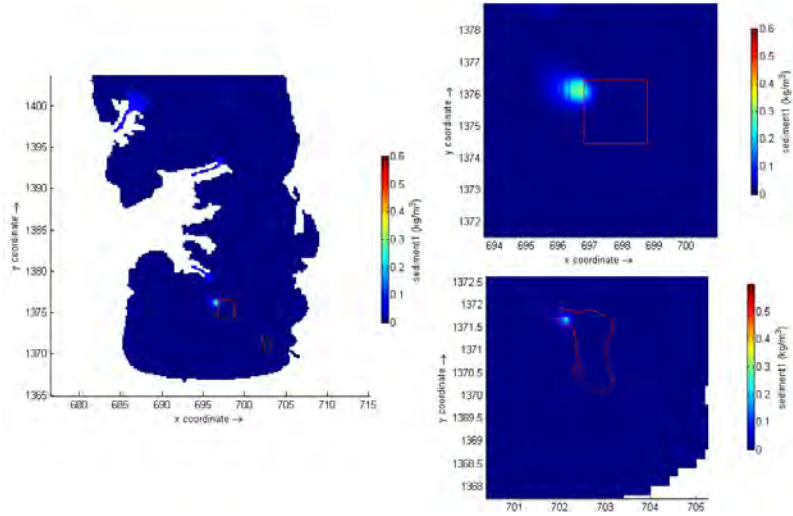

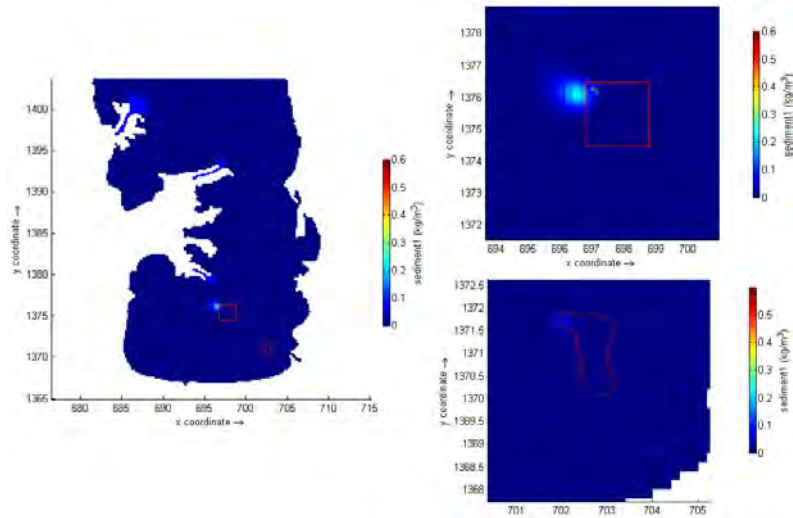

d. 08/Jan 18:30



e. 08/Jan 19:30

Figure Num. 3.57. Dispersion of total suspended solids for a discharge
Source: Aqua & Terra Consultores Asociados, 2015

To have a better perception of what was described above, this document has attached a series of videos where for the first and second semester modeled. This model makes it possible to demonstrate, simultaneously, the dredging and disposal process in the dump.

	ENVIRONMENTAL LICENSE MODIFICATION FOR THE CONSTRUCTION AND OPERATION PROJECT OF A PORT TERMINAL OF SOLID BULK CARGOES IN THE MUNICIPALITY OF TURBO	
	PROJECT DESCRIPTION	Page 133 of 165
	GAT-391-15-CA-AM-PIO-01	Revision:

In addition, to validate the maximum dispersion or dispersion halo, the first unloading of the model is presented on the south western vertex of the dump (N 1,374,755.75 m, E 697,097.53 m).

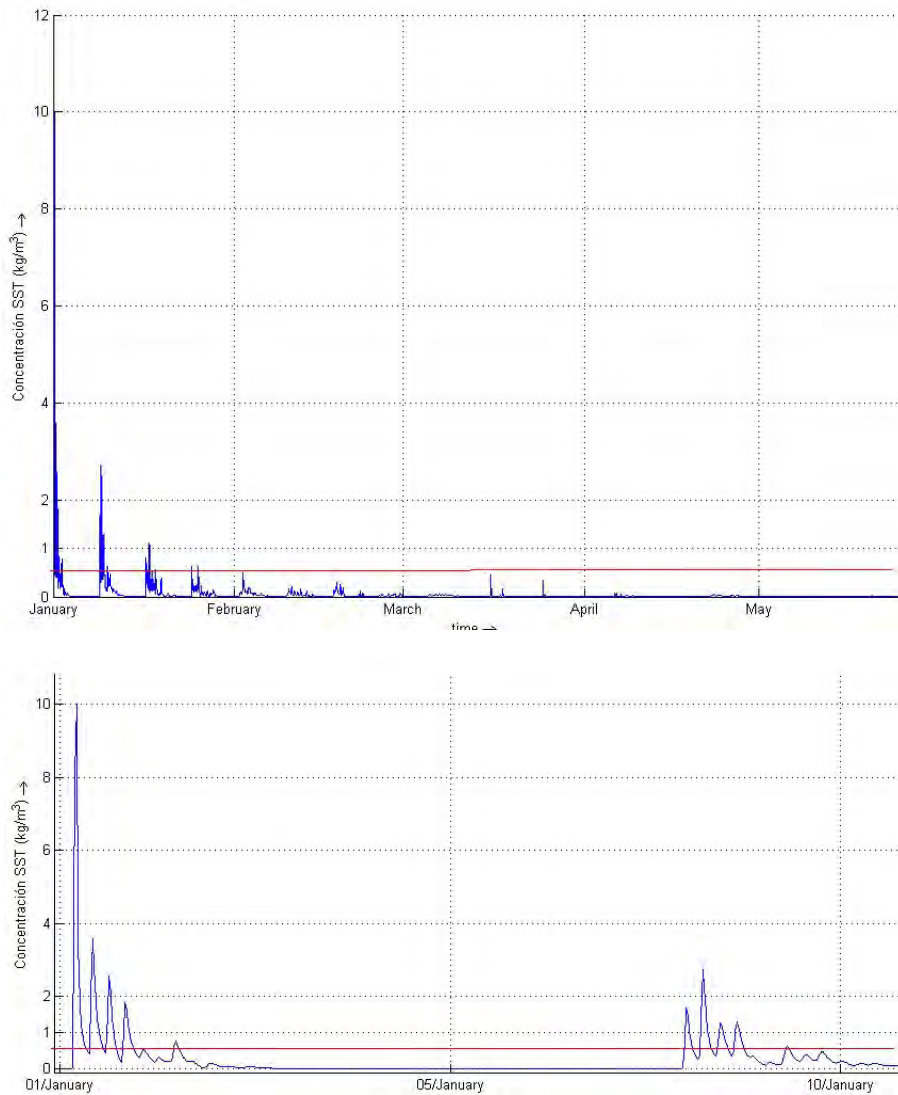



Figure Num. 3.58. SST Concentration of the first semester discharge (N 1,374,755.75 m; E 697,097.53 m).

Source: Aqua & Terra Consultores Asociados



	ENVIRONMENTAL LICENSE MODIFICATION FOR THE CONSTRUCTION AND OPERATION PROJECT OF A PORT TERMINAL OF SOLID BULK CARGOES IN THE MUNICIPALITY OF TURBO	
	PROJECT DESCRIPTION	Page 134 of 165
	GAT-391-15-CA-AM-PIO-01	Revision:

This figure allows us to distinguish several processes among which are: dissipation of the sediment plume at the time of the unloading (where the highest peaks occur) and dispersion by unloadings in neighboring cells (neighboring peaks in the data series). In this way it is evident that once the unloading is made 300 meters to the north (3 cells), according to the dredging route. This confirms again that the dispersion halo or wave dissipation pen for the defined threshold is 300 m from the edge of the dump.

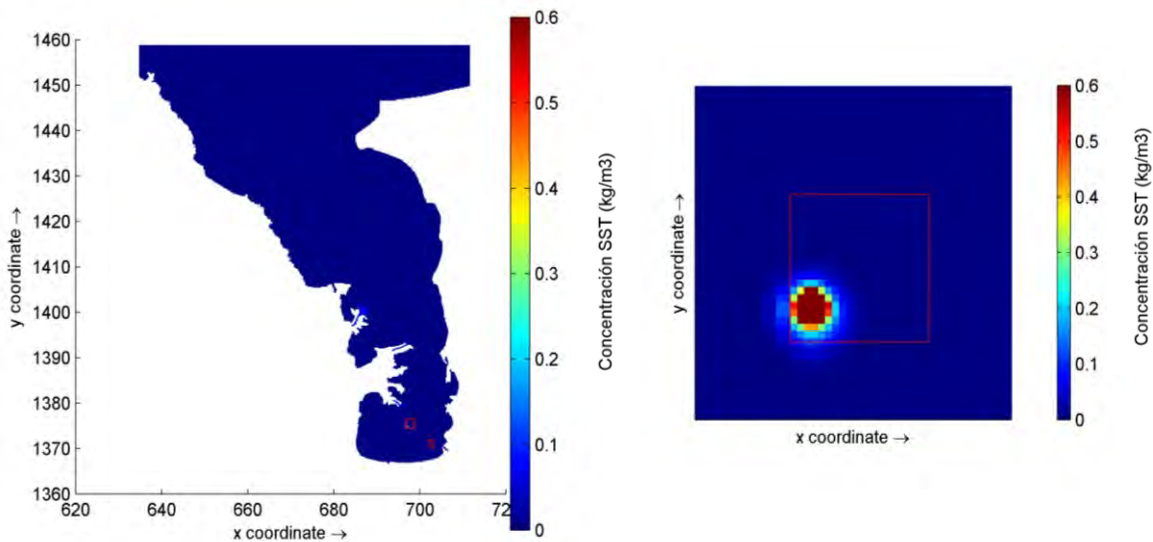

SECOND SEMESTER

A similar procedure was carried out to estimate the dispersion of the sediments during the second half of the year.

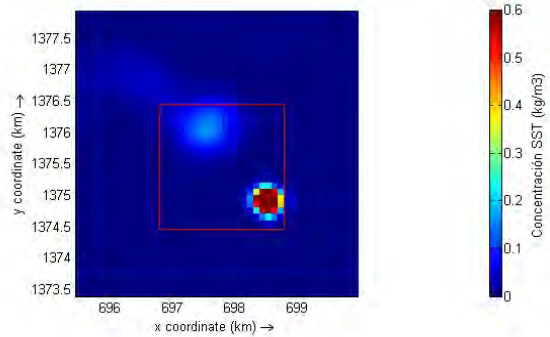
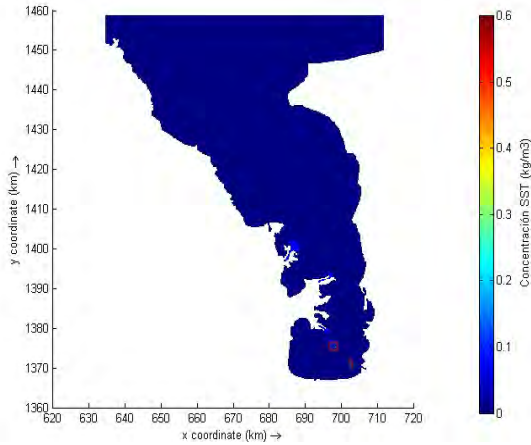
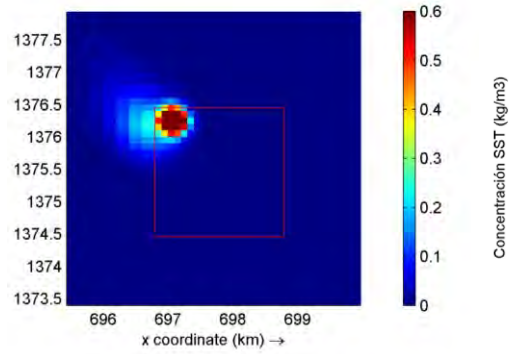
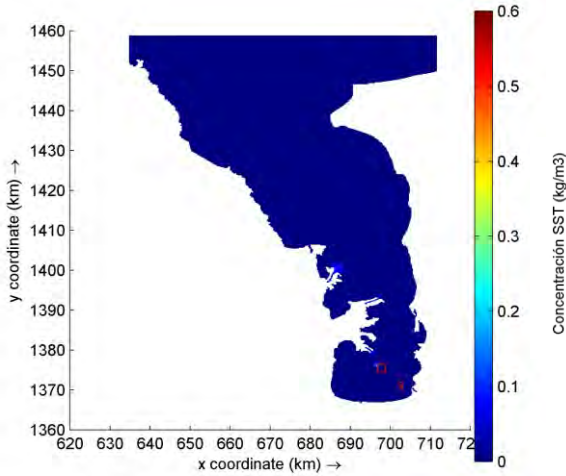

	ENVIRONMENTAL LICENSE MODIFICATION FOR THE CONSTRUCTION AND OPERATION PROJECT OF A PORT TERMINAL OF SOLID BULK CARGOES IN THE MUNICIPALITY OF TURBO	 aqua & terra
	PROJECT DESCRIPTION	Page 135 of 165
	GAT-391-15-CA-AM-PIO-01	Revision:



	ENVIRONMENTAL LICENSE MODIFICATION FOR THE CONSTRUCTION AND OPERATION PROJECT OF A PORT TERMINAL OF SOLID BULK CARGOES IN THE MUNICIPALITY OF TURBO	
	PROJECT DESCRIPTION	Page 136 of 165
	GAT-391-15-CA-AM-PIO-01	Revision:

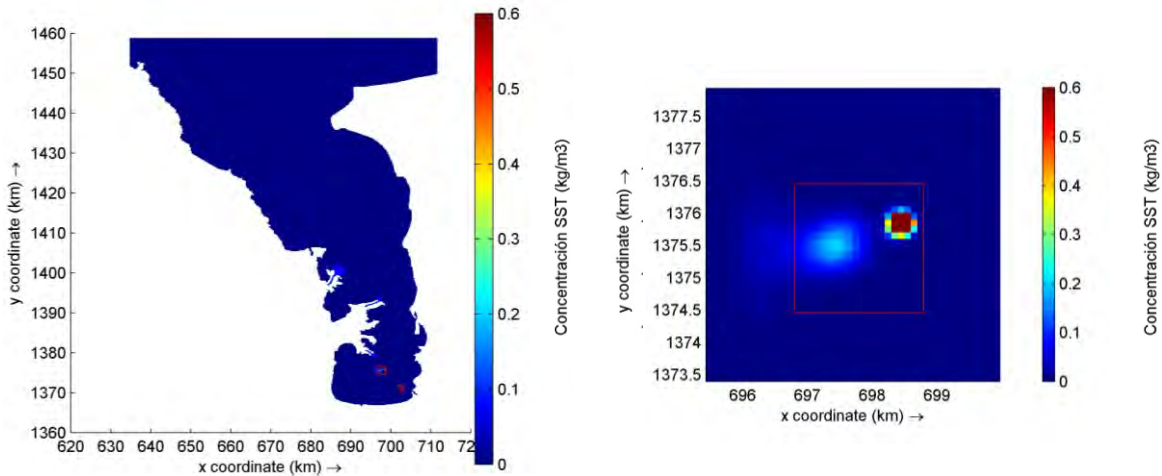



Figure Num. 3.59. Sequence of greater dispersion on the perimeter of the dump, for the second semester of the year.

Source: Aqua & Terra Consultores Asociados

From the previous figure it can be seen how is the dispersion of the sediments in the dump, which shows spatially the concentration of suspended solids in the water column. It can be seen that for the points that are located in the corners of the dump, the dispersion of the sediments does not reach to surpass the area destined for the dumping of dredged material. This confirms once again that the dispersion halo or dispersion plume does not exceed the limit of 2000 m per 2000 m, for the conditions modeled for both the first and second semester.

CONCLUSIONS AND RECOMMENDATIONS

- The dispersion halo in the dump and dredging area does not exceed 300 m in diameter.
- Taking into consideration a dump area of 1400 X 1400 m, the area of influence does not exceed at any time the 2000 X 2000 polygon defined as the maximum area of influence.
- The dispersion of suspended solids (SST) once the material from the dredging is poured, takes approximately 4 hours in the water column to recover its natural condition.
- According to the hydrodynamics of the area, the plume has a tendency to the western side of the dump. For this reason, it is recommended that the spill be developed from the east to the west.

	ENVIRONMENTAL LICENSE MODIFICATION FOR THE CONSTRUCTION AND OPERATION PROJECT OF A PORT TERMINAL OF SOLID BULK CARGOES IN THE MUNICIPALITY OF TURBO	
	PROJECT DESCRIPTION	Page 137 of 165
	GAT-391-15-CA-AM-PIO-01	Revision:

3.3.3 Modeling of heavy metal unloadings according to the type of dredging

Initially, the quality of deep sea sediments has been characterized to determine the impact they have on the dredging activity and disposal of the material in the dump.

3.3.3.1 Quality of deep sea sediments

In order to know the characteristics of the deep sea sediment in the areas where the deepening dredging activities will be carried out, samples from three (3) drilling were made in Bahía Colombia, located in the Golfo de Urabá, denominated PF8, PF9 and PF10, taking into account that the genesis of these sediments and their formation are mainly due to the same sedimentary dynamics in the whole area, coming from León and Atrato rivers, so it can be affirmed and expected to be very uniform throughout and width of the project area.



The plane coordinates and the location of the drilling points for the sediment analysis are presented in Table Num. 3.21 and Figure Num. 3.60, respectively.

Table Num. 3.21. Coordinates of the perforations

Perforation	Coordinates	
	Magna Sirgas Bogotá origin	
	East	North
PF-8	703.242,56	1.370.757,58
PF-9	702.766,57	1.370.550,31
PF-10	702.771,47	1.371.303,17

Source: EDIFICA COLOMBIA LDTA, PIO S.A.S, 2015³²

³² EDIFICA COLOMBIA LDTA, PIO S.A.S, PUERTO ANTIOQUIA. Geotechnical study for conceptual engineering. Puerto Antioquia Port Terminal. Bogotá D.C, 2015

	ENVIRONMENTAL LICENSE MODIFICATION FOR THE CONSTRUCTION AND OPERATION PROJECT OF A PORT TERMINAL OF SOLID BULK CARGOES IN THE MUNICIPALITY OF TURBO	
	PROJECT DESCRIPTION	Page 138 of 165
	GAT-391-15-CA-AM-PIO-01	Revision:

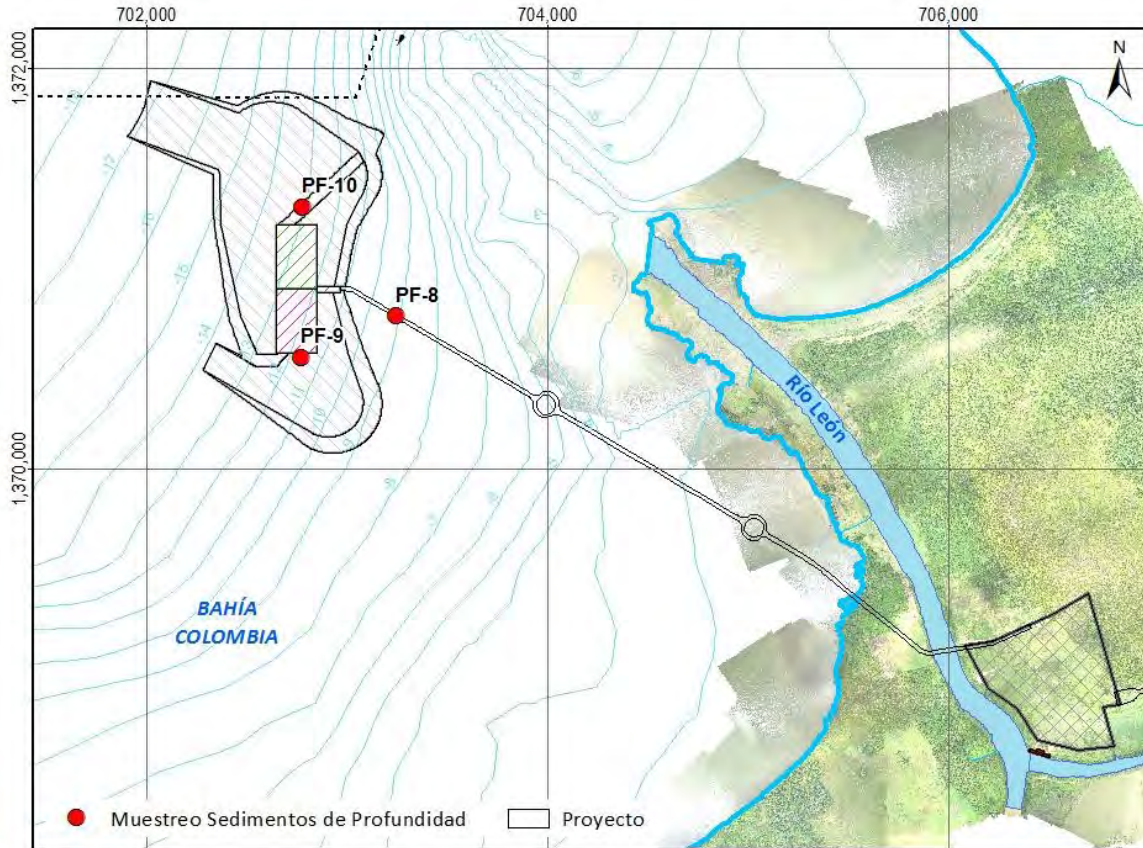



Figure Num. 3.60 Location of perforations
Source: Aqua & Terra Consultores Asociados S.A.S. (2015)

Red: Depth sediment sample

White: Project

Drilling PF-08 is located in the area of the viaduct and it will not be necessary to carry out dredging at this point. The other two points (PF-09 and PF-10) correspond to the areas where deepening dredging would be carried out to adapt the maneuvering

	ENVIRONMENTAL LICENSE MODIFICATION FOR THE CONSTRUCTION AND OPERATION PROJECT OF A PORT TERMINAL OF SOLID BULK CARGOES IN THE MUNICIPALITY OF TURBO	
	PROJECT DESCRIPTION	Page 139 of 165
	GAT-391-15-CA-AM-PIO-01	Revision:

areas of the vessels and deep draft vessels that will reach the maritime terminal at the operation stage.³³

Samples were taken on March 25, 2015 by drilling with Shelby tube. These implements were also used for storage and transportation until delivery to the laboratories on August 14, 2015.

Four (4) samples were taken from each perforation at different depths, so that from the analyzes the different environmental aspects associated with the dredging activity could be inferred and, in turn, anticipate the possible effects on the water column of the deposition of dredged material in the area assigned as a dump and, thus, propose management measures for the environmental impacts that may arise.

3.3.3.2 Results obtained from depth sediment sampling

Table Num. 3.22 shows the results obtained from the analyzes carried out by each laboratory.

³³ ALVAREZ-GUERRA, M., VIGURI, J. R., CASADO-MARTÍNEZ, M. C., & DELVALLS, T. Á. (2007). Sediment Quality Assessment and Dredged Material Management in Spain: Part I, Application of Sediment Quality Guidelines in the Bay of Santander. *Integrated Environmental Assessment and Management*, 3(4), 529. http://doi.org/10.1897/IEAM_2006-055.1



	ENVIRONMENTAL LICENSE MODIFICATION FOR THE CONSTRUCTION AND OPERATION PROJECT OF A PORT TERMINAL OF SOLID BULK CARGOES IN THE MUNICIPALITY OF TURBO												
	DESCRIPCIÓN DEL PROYECTO											Page 140 of 165	
	GAT-391-15-CA-AM-PIO-01											Revision:	

Table Num. 3.22. Results of analysis of the physico-chemical quality of deep sea sediments

Parámetro	PF-8				PF-9				PF-10				CEDEX (España)	
	M1 9,0 - 9,6 m	M2 12,0 - 12,6 m	M3 18,0-18,6 m	M4 20,5- 21,1 m	M1 12,0-12,6 m	M2 15,0-15,6 m	M3 18,0-18,6 m	M4 21,0-21,6 m	M1 13,0-13,6 m	M2 15,75-16,35 m	M3 18,5-19,1 m	M4 21,25-21,50 m	AL1	AL2
Físicos														
Temperatura (°C)	23,4	24,3	24,1	24,2	24	23,7	23,6	24,6	24,1	23,9	24	24,1	-	-
Potencial de Hidrogeno - pH	8,13	8,15	8,34	8,49	7,92	8,34	8,36	6,56	6,28	8,16	8,28	8,35	-	-
Químicos														
Grasas y aceites (mg/kg)	525	386	510	514	546	925	891	676	533	1064	432	<200	-	-
Arsénico (mg/kg)	4,6	4,4	5	4,6	4,6	5	5,6	6	4,2	4,8	3	4,6	80,00	200,00
Bario (mg/kg)	24,3	25,1	<23,0	<23,0	59,8	<23,0	24,8	52,2	73,1	<23,0	<23,0	<23,0	-	-
Cadmio (mg/kg)	<7,72	<7,72	<7,72	<7,72	<7,72	<7,72	<7,72	<7,72	<7,72	<7,72	<7,72	<7,72	1,00	5,00
Zinc (mg/kg)	36	32	32	32	38	42	30	32	32	30	32	34	500,00	3000,00
Cromo (mg/kg)	56	52	66	60	58	66	144	56	48	64	50	60	200,00	1000,00
Cromo hexavalente (mg/kg)	<0,25	<0,25	<0,25	<0,25	<0,25	<0,25	<0,25	<0,25	<0,25	<0,25	<0,25	<0,25	-	-
Cobre (mg/kg)	63,7	73,8	68,1	59,3	61,4	59,5	66,1	46,1	<27,5	66,9	62,3	31,3	100,00	400,00
Mercurio (mg/kg)	2	<1,8	1,8	<1,8	3,2	<1,8	2,2	<1,8	<1,8	2	<1,8	<1,8	0,60	3,00
Níquel (mg/kg)	56	60	66	64	60	66	70	56	54	64	46	66	100,00	400,00
Plomo (mg/kg)	24	20	28	24	20	36	32	32	<20	32	22	26	120,00	600,00
Selenio (mg/kg)	0,15	0,161	0,147	0,132	0,152	0,136	0,142	0,155	0,153	0,133	0,136	0,141	-	-
Hidrocarburos Totales %	<0,00625	<0,00625	<0,00625	<0,00625	<0,00625	<0,00625	<0,00625	<0,00625	<0,00625	<0,00625	<0,00625	<0,00625	-	-
Fenoles (mg/kg)	<0,35	<0,35	<0,35	<0,35	<0,35	<0,35	<0,35	<0,35	<0,35	<0,35	<0,35	<0,35	-	-
HAPs (mg/kg)	<0,03	<0,03	<0,03	<0,03	<0,03	<0,03	<0,03	<0,03	<0,03	<0,03	<0,03	<0,03	-	-
Carbono Orgánico Total (mg/kg)	22545	35121	31069	28832	19713	24001	24046	24341	15676	23469	15789	22612	-	-
Fósforo Total (mg/kg)	<1,50	<1,50	3,51	1,68	2,16	5,81	7,95	1,68	2	5,02	6,6	8,79	-	-
Nitrógeno Total (mg/kg)	1543,13	1480,86	1789	2840,62	1623,97	1309,67	1965,04	1366	1497,27	1390,47	2717,91	4385,62	-	-
Sulfuro Ácido Volátil (SAV) (%P/P)			9,26		7,52	2,15			6,90	1,00			-	-

Source: Aqua & Terra Consultores Asociados S.A.S. (2015)

DESCRIPCIÓN DEL PROYECTO
CAP 3 TDENG-CAT-REV-DAV-OK
[[Medellin], 2015



ENVIRONMENTAL LICENSE MODIFICATION FOR THE CONSTRUCTION AND OPERATION
PROJECT OF A PORT TERMINAL OF SOLID BULK CARGOES IN THE MUNICIPALITY OF
TURBO



DESCRIPCIÓN DEL PROYECTO



Page 141 of 165

GAT-391-15-CA-AM-PIO-01

Revision:

Figure Translation	
Parameter	
Physical	Temperature (°C)
	Hydrogen Potential - pH
Chemical	Fats and oils (mg / kg)
	Arsenic (mg / kg)
	Barium (mg/kg)
	Cadmium (mg/kg)
	Zinc (mg/kg)
	Chrome (mg/kg)
	Hexavalent chromium (mg / kg)
	Copper (mg/kg)
	Mercury (mg/kg)
	Nickel (mg/kg)
	Silver (mg/kg)
	Lead (mg/kg)
	Selenium (mg/kg)
	Total Hydrocarbons%
	Phenols (mg/kg)
	HAP's (mg/kg)
	Total Organic Carbon (mg / kg)
Total phosphorus (mg / kg)	
Total Nitrogen (mg / kg)	
Volatile Acid Sulphide (SAV) (% P / P)	

DESCRIPCIÓN DEL PROYECTO
CAP 3 TDENG-CAT-REV-DAV-OK
[[Medellin], 2015

	ENVIRONMENTAL LICENSE MODIFICATION FOR THE CONSTRUCTION AND OPERATION PROJECT OF A PORT TERMINAL OF SOLID BULK CARGOES IN THE MUNICIPALITY OF TURBO		
	DESCRIPCIÓN DEL PROYECTO	Page 142 of 165	
	GAT-391-15-CA-AM-PIO-01	Revision:	B

3.3.3.3 Analysis and comparison with the regulations

Visual characteristics of the samples

The visual characteristics of the samples varied according to the depth at which they were taken. In general terms we can say:

- Samples from the layer closest to the surface of the seabed (9.0-9.6 m) were made of silty clay with high humidity and plasticity, in addition to having a soft consistency.
- In the samples taken in the following depth (12.0-12.6 m) there was greenish gray clay with some silt, high humidity and soft consistency.
- The analysis of sediments of the posterior layer in depth (18.0-18.6 m), allowed to observe a layer of gray clay with some silt, high plasticity and high humidity.
- Finally, the samples of the deepest layer (20.5-21.1 m) could be described as gray-green clay with high plasticity and humidity.

This predominance of clay and muddy beds is related to a large extent by the contributions of sediments from the main rivers of the area, within which there are some branches of Atrato and León rivers.³⁴



Comparison with regulations

Colombia does not have regulations regarding the characteristics of marine sediments produced by dredged material. For this reason, were used as guide values for the comparison with the results of the physicochemical analyzes, those established by the Center for Studies and Experimentation of Public Works (CEDEX) of Spain³⁵.

This document establishes action levels according to the determined concentration for each parameter evaluated. From these levels, the sediments are classified into four categories.

³⁴ CHEVILLOT, P., MOLINA, A., GIRALDO, L., & MOLINA, C. (1993). Geological and hydrological study of the Golfo de Urabá. Scientific Bulletin CIOH, (14), 79-89.

³⁵ MINISTRY OF PUBLIC WORKS, TRANSPORTATION AND ENVIRONMENT. (1994). Recommendations for the management of dredged material in Spanish ports. Madrid Spain.

	ENVIRONMENTAL LICENSE MODIFICATION FOR THE CONSTRUCTION AND OPERATION PROJECT OF A PORT TERMINAL OF SOLID BULK CARGOES IN THE MUNICIPALITY OF TURBO		
	DESCRIPCIÓN DEL PROYECTO	Page 143 of 165	
	GAT-391-15-CA-AM-PIO-01	Revision:	B

The comparison with the Spanish regulations is made for each point independently, indicating the corresponding category for those parameters that have reference values. It is important to clarify that some of the evaluated parameters do not have international reference values, for this reason it is not possible to classify them according to a norm, instead, the related researches published in internationally recognized scientific journals will be used as references.



Table Num. 3.23 shows the threshold values associated with each action level for each analyzed parameter.

Table Num. 3.23. Values associated with Action Levels 1 and 2 in the Spanish standard

Parameter		CEDEX (Spain) ³⁶	
		AL1 (mg/kg)	AL2 (mg/kg)
Physical	Temperature	-	-
	Hydrogen Potential – pH	-	-
Chemical	Fats and oils	-	-
	Arsenic	80,00	200,00
	Barium	-	-
	Cadmium	1,00	5,00
	Zinc	500,00	3000,00
	Chrome	200,00	1000,00
	Hexavalent chromium	-	-
	Copper	100,00	400,00
	Mercury	0,60	3,00
	Nickel	100,00	400,00
	Silver	-	-
	Lead	120,00	600,00
	Selenium	-	-
	Total Hydrocarbons	-	-
	Phenols	-	-
	HAP's	-	-
	Total organic carbon	-	-
Volatile Acid Sulphide	-	-	
Total phosphorus	-	-	
Total Nitrogen	-	-	

Source: Aqua & Terra Consultores Asociados S.A.S. (2015)

³⁶ Ibid.
DESCRIPCIÓN DEL PROYECTO
CAP 3 TDENG-CAT-REV-DAV-OK
[[Medellín], 2015

	ENVIRONMENTAL LICENSE MODIFICATION FOR THE CONSTRUCTION AND OPERATION PROJECT OF A PORT TERMINAL OF SOLID BULK CARGOES IN THE MUNICIPALITY OF TURBO	
	DESCRIPCIÓN DEL PROYECTO	Page 144 of 165
	GAT-391-15-CA-AM-PIO-01	Revision: B

According to the classification made by CEDEX³⁷ the following is established:

AL1 and AL2: They are the action levels 1 and 2, which correspond to the limit values used for the classification of the degree of contamination of the dredged material according to the following categories:

- *Category I:* When the value is less than AL1. This category includes dredged material from port funds whose chemical and/or biochemical effects on maritime ecosystems are insignificant.
- *Category II:* When the value obtained is between AL1 and AL2. In this case there is a moderate concentration of pollutants and unloadings of material dredged to the sea should be made regarding special considerations related to site selection, impact assessment and environmental monitoring programs in the area.
- *Category III:* When the value of AL2 is exceeded. Dredged materials with a high concentration of contaminants belong to this category, therefore they must be isolated from marine waters or subjected to special treatments prior to disposal in the dumping area.³⁸

Within category III we find two subgroups:

- The category IIIa. Within this category are materials whose concentration of contaminants exceeds the action level 02 but are below eight (08) times the value of AL2. Corresponds to materials that require soft insulation management techniques such as underwater confinement and unload into aquatic or terrestrial enclosure.³⁹
- Category IIIb are those materials whose concentration of contaminants is greater than eight (08) times the value of AL2. They require hard treatment and storage techniques, such as pouring into enclosures with specific characteristics (impermeable walls, leachate control devices, among others) for the storage of these, the "on line" treatment before making unloadings into the sea and Solidification or inertization for land disposal.

For a better visualization of the comparisons between the results and the Spanish standard, a color will be assigned to each category, as shown in Table Num. 3.24.

³⁷ Ibid.

³⁸ Ibid.

³⁹ Ibid.



	ENVIRONMENTAL LICENSE MODIFICATION FOR THE CONSTRUCTION AND OPERATION PROJECT OF A PORT TERMINAL OF SOLID BULK CARGOES IN THE MUNICIPALITY OF TURBO		
	DESCRIPCIÓN DEL PROYECTO	Page 145 of 165	
	GAT-391-15-CA-AM-PIO-01	Revision:	B

Table Num. 3.24. CEDEX category for dredged material based on the concentration of pollutants

Category I	
Category II	
Category IIIa	
Category IIIb	

Source: Aqua & Terra Consultores Asociados S.A.S. (2015)

Based on the information above, we proceed to perform the analysis of the results obtained in each drilling. Next, the concentrations corresponding to the different samples of each point are presented.



3.3.3.3.1 PF8 Perforation

Table Num. 3.25 shows the results of all the samples taken in the PF8 drilling compared with the standard CEDEX standard⁴⁰ and it is classified by color and category according to Table Num. 3.24.

Table Num. 3.25. Comparison of results in PF8 with the Spanish norm and classification of the results

Parameter		PF-8				CEDEX (Spain)		Classification of the result with the CEDEX Category
		M1 9,0 - 9,6 m	M2 12,0 - 12,6 m	M3 18,0 - 18,6 m	M4 20,5- 21,1 m	AL1	AL2	
Physical	Temperature (°C)	23,4	24,3	24,1	24,2	-	-	N/A
	Hydrogen Potential - pH	8,13	8,15	8,34	8,49	-	-	N/A
Chemical	Fats and oils (mg / kg)	525	386	510	514	-	-	N/A
	Arsenic (mg / kg)	4,6	4,4	5	4,6	80,00	200,00	I
	Barium (mg/kg)	24,3	25,1	<23.0	<23.0	-	-	N/A
	Cadmium (mg/kg)	<7.72	<7.72	<7.72	<7.72	1,00	5,00	N/A
	Zinc (mg/kg)	36	32	32	32	500,00	3000,00	I
	Chrome (mg/kg)	56	52	66	60	200,00	1000,00	I
	Hexavalent chromium (mg / kg)	<0.25	<0.25	<0.25	<0.25	-	-	N/A
Copper (mg/kg)	63,7	73,8	68,1	59,3	100,00	400,00	I	

⁴⁰ MINISTRY OF PUBLIC WORKS, TRANSPORTATION AND ENVIRONMENT. (1994). Recommendations for the management of dredged material in Spanish ports. Madrid Spain.

	ENVIRONMENTAL LICENSE MODIFICATION FOR THE CONSTRUCTION AND OPERATION PROJECT OF A PORT TERMINAL OF SOLID BULK CARGOES IN THE MUNICIPALITY OF TURBO		
	DESCRIPCIÓN DEL PROYECTO	Page 146 of 165	
	GAT-391-15-CA-AM-PIO-01	Revision:	B

Parameter	PF-8				CEDEX (Spain)		Classification of the result with the CEDEX Category
	M1 9,0 - 9,6 m	M2 12,0 - 12,6 m	M3 18,0 - 18,6 m	M4 20,5- 21,1 m	AL1	AL2	
Mercury (mg/kg)	2	<1.8	1,8	<1.8	0,60	3,00	II
Nickel (mg/kg)	56	60	66	64	100,00	400,00	I
Silver (mg/kg)	<18	<18	<18	<18	-	-	N/A
Lead (mg/kg)	24	20	28	24	120,00	600,00	I
Selenium (mg/kg)	0,15	0,161	0,147	0,132	-	-	N/A
Total Hydrocarbons%	<0.00625	<0.00625	<0.00625	<0.00625	-	-	N/A
Phenols (mg/kg)	<0.35	<0.35	<0.35	<0.35	-	-	N/A
HAP's (mg/kg)	<0.03	<0.03	<0.03	<0.03	-	-	N/A
Total Organic Carbon (mg / kg)	22545	35121	31069	28832	-	-	N/A
Total phosphorus (mg / kg)	<1.50	<1.50	3,51	1,68	-	-	N/A
Total Nitrogen (mg / kg)	1543,13	1480,86	1789	2840,62	-	-	N/A
Volatile Acid Sulphide (SAV) (% P / P)			9.26				N/A



Source: Aqua & Terra Consultores Asociados S.A.S. (2015)

Arsenic, zinc, chromium, copper, nickel and lead were located well below the limit that defines Action Level 1. On the other hand, mercury concentrations were recorded in the range of 0.6 - 3.0 mg / kg for M1 and M3 samples.

According to the results presented in Table Num. 3.25., the dredging material from the depths of 9,0-9,6 m y 18,0-18,6 m, it belongs to category II since the mercury reaches a moderate concentration. For the other pollutants, the concentrations do not reach risk levels for the aquatic ecosystem.

The result of the sample M1 (9.0 - 9.6 m) is of particular interest for the present study, because it is located at a depth to which dredging will be carried out. While the sample M3 (18.0-18.6 m) is part of the characterization of the area of influence only because the dredging will not reach that depth at this point.

Additionally, it should be noted that samples M2 (12.0-12.6m) and M4 (20.5-21.1m) had mercury concentrations below the limit of detection of the analytical technique used by the laboratory, for this reason it was possible to define the classification of the samples according to the CEDEX categories.



	ENVIRONMENTAL LICENSE MODIFICATION FOR THE CONSTRUCTION AND OPERATION PROJECT OF A PORT TERMINAL OF SOLID BULK CARGOES IN THE MUNICIPALITY OF TURBO		
	DESCRIPCIÓN DEL PROYECTO	Page 147 of 165	
	GAT-391-15-CA-AM-PIO-01	Revision:	B

3.3.3.3.2 PF9 Perforation

In the Table Num. 3.26 the results of all the samples taken at different depths in the PF9 drilling are compared with the CEDEX standard.

Table Num. 3.26. Comparison of results in PF9 with the Spanish norm and classification of the result.

Parameter	PF-9				CEDEX (Spain)		Classification of the result with the CEDEX Category	
	M1 12,0- 12,6 m	M2 15,0- 15,6 m	M3 18,0- 18,6 m	M4 21,0- 21,6 m	AL1	AL2		
Physical	Temperature (°C)	24	23,7	23,6	24,6	-	-	N/A
	Hydrogen Potential - pH	7,92	8,34	8,36	6,56	-	-	N/A
Chemical	Fats and oils (mg / kg)	546	925	891	676	-	-	N/A
	Arsenic (mg / kg)	4,6	5	5,6	6	80,00	200,00	I
	Barium (mg/kg)	59,8	<23.0	24,8	52,2	-	-	N/A
	Cadmium (mg/kg)	<7.72	<7.72	<7.72	<7.72	1,00	5,00	N/A
	Zinc (mg/kg)	38	42	30	32	500,0 0	3000,0 0	I
	Chrome (mg/kg)	58	66	144	56	200,0 0	1000,0 0	I
	Hexavalent chromium (mg / kg)	<0.25	<0.25	<0.25	<0.25	-	-	N/A
	Copper (mg/kg)	61,4	59,5	66,1	46,1	100,0 0	400,00	I
	Mercury (mg/kg)	3,2	<1.8	2,2	<1.8	0,60	3,00	IIIa
	Nickel (mg/kg)	60	66	70	56	100,0 0	400,00	I
	Silver (mg/kg)	<18	<18	<18	<18	-	-	N/A
	Lead (mg/kg)	20	36	32	32	120,0 0	600,00	I
	Selenium (mg/kg)	0,152	0,136	0,142	0,155	-	-	N/A
	Total Hydrocarbons%	<0.0062 5	<0.0062 5	<0.0062 5	<0.0062 5	-	-	N/A
	Phenols (mg/kg)	<0.35	<0.35	<0.35	<0.35	-	-	N/A
	HAP's (mg/kg)	<0.03	<0.03	<0.03	<0.03	-	-	N/A
Total Organic Carbon (mg / kg)	19713	24001	24046	24341	-	-	N/A	
Total phosphorus (mg / kg)	2,16	5,81	7,95	1,68	-	-	N/A	

	ENVIRONMENTAL LICENSE MODIFICATION FOR THE CONSTRUCTION AND OPERATION PROJECT OF A PORT TERMINAL OF SOLID BULK CARGOES IN THE MUNICIPALITY OF TURBO	
	DESCRIPCIÓN DEL PROYECTO	Page 148 of 165
	GAT-391-15-CA-AM-PIO-01	Revision: B

Parameter	PF-9				CEDEX (Spain)		Classification of the result with the CEDEX Category
	M1 12,0- 12,6 m	M2 15,0- 15,6 m	M3 18,0- 18,6 m	M4 21,0- 21,6 m	AL1	AL2	
Total Nitrogen (mg / kg)	1623,97	1309,67	1965,04	1366	-	-	N/A
Volatile Acid Sulphide (SAV) (% P / P)	7.52	2.15					

Source: Aqua & Terra Consultores Asociados S.A.S. (2015)

As in point PF8, arsenic, zinc, chromium, copper, nickel and lead were located well below the limit defined by Action Level 1. On the other hand, mercury concentrations of sample M1 (depth between 12.0-12.6 m) exceeded by 6% the level of action 02 since the norm establishes a limit of 3 mg / kg and in the sample 3.2 mg / kg was found, being very close to the threshold, and it can be observed in the sample of the following depth M2, that the concentration of mercury is lower than 1.8 mg/kg of Hg, establishing us in Action Level 02, so we can think that it is not an area with a high degree of mercury concentrations since it only exceeds the action level 02 in a very low percentage; close to the margin of error of the same test.

On the other hand, at a greater depth in the M3 sample (depth between 18.0-18.6 m) they were in the range between 0.6-3.0 mg/kg Hg, thus confirming the previously analyzed.

Therefore, according to the results presented in the Table Num. 3.26, the material to be dredged from sample M1 (depth between 12 - 12.6 m) belongs to category IIIa and the material from samples M2 and M3 (depth between 15 -15.6 and 18 - 18.6 m respectively) belong to Category II; said material will not be dredged. Regarding other pollutants, the concentrations do not reach risk levels for the aquatic ecosystem.

On the other hand, it is important to clarify that samples M2 (depth between 15.0-15.6m) and M4 (depth between 21.0-21.6m) presented mercury concentrations below the limit of detection of the analytical technique used by the laboratory, for this reason it is not possible to define the classification of the samples according to the CEDEX categories.

3.3.3.3.3 PF10 Perforation

Table Num. 3.27 shows the results of all the samples taken for different depths in the PF10 drilling compared with the CEDEX standard

DESCRIPCIÓN DEL PROYECTO
CAP 3 TDENG-CAT-REV-DAV-OK
[[Medellín], 2015





	ENVIRONMENTAL LICENSE MODIFICATION FOR THE CONSTRUCTION AND OPERATION PROJECT OF A PORT TERMINAL OF SOLID BULK CARGOES IN THE MUNICIPALITY OF TURBO		
	DESCRIPCIÓN DEL PROYECTO	Page 149 of 165	
	GAT-391-15-CA-AM-PIO-01	Revision:	B

Table Num. 3.27. Comparison of results in PF10 with the Spanish norm and classification of the result.

Parameter	PF-10				CEDEX (Spain)		Classification of the result with the CEDEX Category	
	M1 13,0-13,6 m	M2 15,75- 16,35 m	M3 18,5-19,1 m	M4 21,25- 21,50 m	AL1	AL2		
Physical	Temperature (°C)	24,1	23,9	24	24,1	-	-	N/A
	Hydrogen Potential - pH	6,28	8,16	8,28	8,35	-	-	N/A
Chemical	Fats and oils (mg / kg)	533	1064	432	<200	-	-	N/A
	Arsenic (mg / kg)	4,2	4,8	3	4,6	80,00	200,00	I
	Barium (mg/kg)	73,1	<23.0	<23.0	<23.0	-	-	N/A
	Cadmium (mg/kg)	<7.72	<7.72	<7.72	<7.72	1,00	5,00	N/A
	Zinc (mg/kg)	32	30	32	34	500,00	3000,00	I
	Chrome (mg/kg)	48	64	50	60	200,00	1000,00	I
	Hexavalent chromium (mg / kg)	<0.25	<0.25	<0.25	<0.25	-	-	N/A
	Copper (mg/kg)	<27.5	66,9	62,3	31,3	100,00	400,00	I
	Mercury (mg/kg)	<1.8	2	<1.8	<1.8	0,60	3,00	II
	Nickel (mg/kg)	54	64	46	66	100,00	400,00	I
	Silver (mg/kg)	<18	<18	<18	<18	-	-	N/A
	Lead (mg/kg)	<20	32	22	26	120,00	600,00	I
	Selenium (mg/kg)	0,153	0,133	0,136	0,141	-	-	N/A
	Total Hydrocarbons%	<0.00625	<0.00625	<0.00625	<0.00625	-	-	N/A
	Phenols (mg/kg)	<0.35	<0.35	<0.35	<0.35	-	-	N/A
	HAP's (mg/kg)	<0.03	<0.03	<0.03	<0.03	-	-	N/A
	Total Organic Carbon (mg / kg)	15676	23469	15789	22612	-	-	N/A
	Total phosphorus (mg / kg)	2	5,02	6,6	8,79	-	-	N/A
Total Nitrogen (mg / kg)	1497,27	1390,47	2717,91	4385,62	-	-	N/A	
Volatile Acid Sulphide (SAV) (% P / P)	6,9	1,00						

Source: Aqua & Terra Consultores Asociados S.A.S. (2015)

In drilling PF10 the trend of the previous points is maintained, where most of the parameters comply with what is established by the Spanish standard: arsenic, zinc, chromium, copper, nickel and lead, were located well below the limit that defines the

	ENVIRONMENTAL LICENSE MODIFICATION FOR THE CONSTRUCTION AND OPERATION PROJECT OF A PORT TERMINAL OF SOLID BULK CARGOES IN THE MUNICIPALITY OF TURBO		
	DESCRIPCIÓN DEL PROYECTO	Page 150 of 165	
	GAT-391-15-CA-AM-PIO-01	Revision:	B

Action level 1. On the other hand, the mercury concentrations of sample M2 (depth between 15.75-16.35 m) were in the range between 0.6-3.0 mg / kg of Hg.

Therefore, according to the results presented in Table Num. 3.27, The dredged material of sample M2 belongs to category II, given that the mercury reaches a moderate concentration. For the other pollutants, the concentrations do not reach risk levels for the aquatic ecosystem.

On the other hand, it is important to clarify that the samples M1 (13.0-13.6 m), M3 (18.5-19.1 m) and M4 (21.25-21.50 m) presented concentrations of mercury below the limit of detection of the analytical technique used by the laboratory, for this reason it is not possible to define the classification of the samples according to the CEDEX categories.

3.3.3.3.4 Analysis results

Elements such as cadmium, zinc, chromium, copper, mercury, nickel and lead have been widely studied due to their environmental importance, the effects produced on aquatic biota, the potential for bioaccumulation and their persistence. The results obtained for these elements were compared with the values of marine sediment quality developed in Spain⁴¹, Applicable mainly for dredged material.



These results are presented in chapter 5.1.9 of marine sediment quality in depth. However, in order to have a better approximation of one of the most important components such as mercury (Hg), an analysis of the results is presented below.

❖ Mercury (Hg)

After comparing the results obtained by the laboratory with Spanish regulations (See Figure Num. 3.61), three conditions could be observed:

- In seven (07) of the samples analyzed (samples M2 and M4 from point PF8, samples M2 and M4 from point PF9, and samples M1, M3 and M4 from point PF10), the concentration was lower than the detection limit of the analytical technique used.
- Four (04) of the samples (samples M1 and M3 from point PF8, sample M3 from point PF9, and sample M2 from point PF10) recorded concentrations between 0.6 and 3.0 mg / kg. Therefore, according to the Spanish regulations,

⁴¹ MINISTRY OF PUBLIC WORKS, TRANSPORTATION AND ENVIRONMENT. (1994). Recommendations for the management of dredged material in Spanish ports. Madrid Spain.
DESCRIPCIÓN DEL PROYECTO
CAP 3 TDENG-CAT-REV-DAV-OK
[[Medellín], 2015

	ENVIRONMENTAL LICENSE MODIFICATION FOR THE CONSTRUCTION AND OPERATION PROJECT OF A PORT TERMINAL OF SOLID BULK CARGOES IN THE MUNICIPALITY OF TURBO	
	DESCRIPCIÓN DEL PROYECTO	Page 151 of 165
	GAT-391-15-CA-AM-PIO-01	Revision: B

the sediment is classified as Category II and the concentration of the contaminant is moderate, which is why aspects such as the selection of the site, the evaluation of impacts and the elaboration of a monitoring and surveillance plan, to be able to perform the dredging of the dredged material.

- Only one of the samples (sample M1 of the PF9 point) exceeded by 6% the Action Level 2 (AL2) established by the Spanish standard. For this reason, Category III, subcategory IIIa, is assigned to the dredging material of point PF9, being very demanding since as mentioned above we are very close to the threshold of action category 2.

Taking into account the above, the material of the first layer to be dredged, should be deposited in the central area of the dump, to be later covered with the material coming from the following layers of dredging whose concentrations of mercury are below the action level. 2; and in this way avoid a possible alteration of the ecosystem surrounding the dumping area.

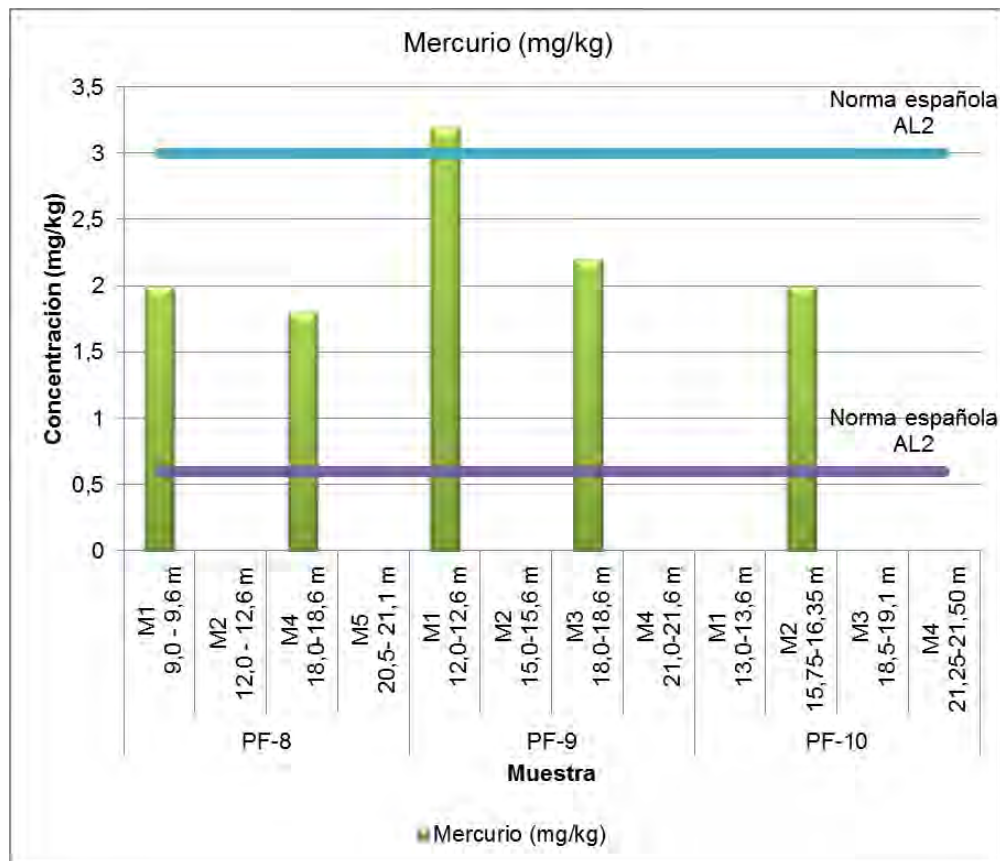



	ENVIRONMENTAL LICENSE MODIFICATION FOR THE CONSTRUCTION AND OPERATION PROJECT OF A PORT TERMINAL OF SOLID BULK CARGOES IN THE MUNICIPALITY OF TURBO		
	DESCRIPCIÓN DEL PROYECTO	Page 152 of 165	
	GAT-391-15-CA-AM-PIO-01	Revision:	B

Figure Num. 3.61. Mercury behavior

Source: Aqua & Terra Consultores Asociados S.A.S. (2015)

Figure Translation
Top: Mercury
Left: concentration
Blue line: Spanish regulation AL2
Purple line: Spanish regulation AL2
Bottom: Sample



That is to say, that the dredged material must be poured into an aquatic enclosure in such a way that there is no significant alteration of the ecosystem surrounding the area of the pouring. For this to occur, it is proposed that the material with high concentrations of mercury be poured into the central part of the area designated as a dump and subsequently covered with dredged material that does not have high concentrations of contaminants.

In this way it is sought that the material that is found with higher concentrations of contaminated sediment is deposited on material with lower concentrations, decreasing the risk of this activity.

Finally, according to the modeling of sediment dispersion, to characterize the behavior of heavy metals in the water column, it has been inferred that the particles of these materials (sediment and heavy metal) are linked to each other.

For this reason, it is to be expected that heavy metals possess the same physical behavior that was described in the modeling of sediment dispersion in the dump. Therefore, it can be seen that the elements found in the sediment column, have a dispersion halo of approximately 300m and a decantation close to 4 hours, at the disposal site of the dredged material.

Additionally, with the methodology that is proposed to carry out the dredging and its disposal, it is guaranteed that the contaminated sediments remain under a layer of clean material. Figure Num. 3.62 shows the spatial and temporal dispersion of the process of dumping the dredged material into the dump area.

	ENVIRONMENTAL LICENSE MODIFICATION FOR THE CONSTRUCTION AND OPERATION PROJECT OF A PORT TERMINAL OF SOLID BULK CARGOES IN THE MUNICIPALITY OF TURBO		
	DESCRIPCIÓN DEL PROYECTO	Page 153 of 165	
	GAT-391-15-CA-AM-PIO-01	Revision:	B

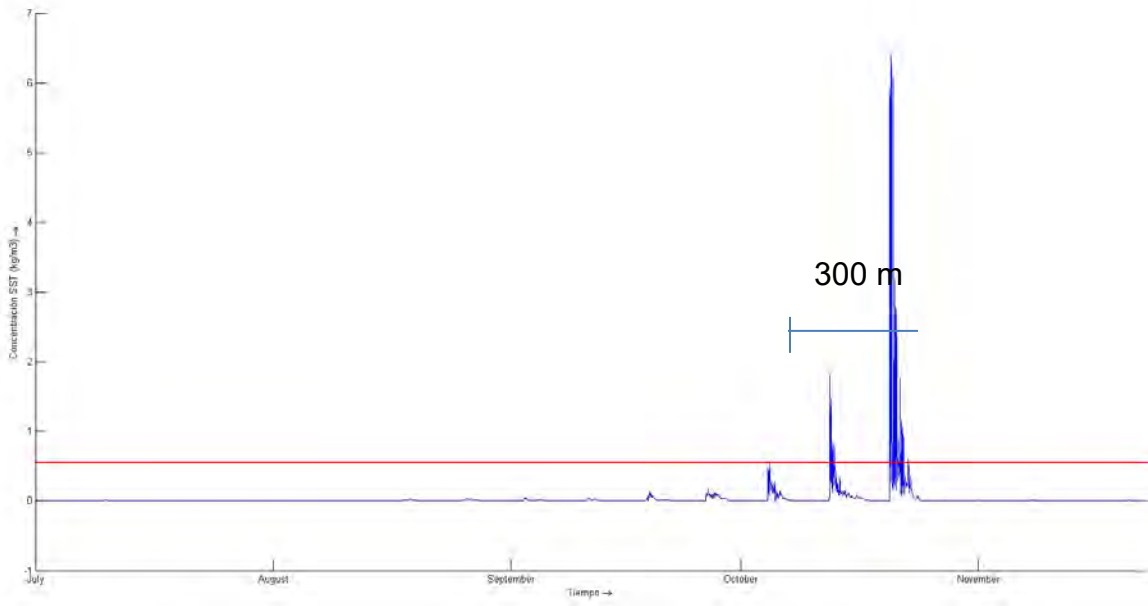



Figure Num. 3.62. Temporary series of material poured into the dump.
Source: Aqua & Terra Consultores Asociados

3.4 Hazardous and non-hazardous waste

The project will not handle any hazardous waste. As mentioned in the previous chapters, heavy maintenance will be carried out in specialized workshops just outside the terminal. On the other hand, the concrete plant will have a closed system of circulation through sedimentation lagoons. However, it is important to distinguish the management that will be given to the waste in the port. For this, an integral management of hazardous, non-hazardous and special solid wastes has been proposed on land and dock. In addition, the integral management of hazardous and non-hazardous solid waste on board the dredge and auxiliary vessels.



For the handling of hazardous and non-hazardous solid waste in the terminal on land and dock, the following sections must be taken into account:

	ENVIRONMENTAL LICENSE MODIFICATION FOR THE CONSTRUCTION AND OPERATION PROJECT OF A PORT TERMINAL OF SOLID BULK CARGOES IN THE MUNICIPALITY OF TURBO		
	DESCRIPCIÓN DEL PROYECTO	Page 154 of 165	
	GAT-391-15-CA-AM-PIO-01	Revision:	B

- Recyclable waste: Can be delivered to authorized third parties for recycling. Among the recyclable waste are cardboard, paper, plastic, glass, aluminum, ferrous metals among others.
- Organic Waste: Can be used to generate by-products in other activities, therefore it will be possible to study alternatives for use such as composting (according to the Technical Regulation of the Drinking Water and Basic Sanitation Sector (RAS 2000), title F), or another option that can be considered viable.
- Waste oil filters: Hydraulic and oil filters or containers that have contained oil should be drained for at least 12 hours, before being placed in containers to prevent the accumulation of oils in them. The place where the oil filters drain must be waterproofed and must have a spill control system.
- Hazardous Waste: Any container or residue of a material or substance classified as hazardous should be handled as a hazardous material. Likewise, containers or other packaging must be properly labeled with their corresponding number and code.
- Special waste: debris, concrete and loose aggregates construction and demolition products must be delivered for management and disposal to authorized third parties. The soil and subsoil of excavation may be used for the construction of jars or works required. Batteries for light, medium and heavy vehicles will be returned to the supplier or must be handed over to authorized third parties that have valid environmental permits. Aerosol jars and paint jars that cannot be used as scrap for their high content of paint residues, will be stored in a hermetically sealed container, and authorized third parties will be delivered. Obsolete equipment and scrap must be stored and may be sold to third parties for use as raw material. These materials must be located in a collection center.
- The collection centers should be located in an area where it is avoided contaminating the waters of The León River, the Nueva Colonia Canal and / or the surrounding sewers.
- The collection centers should have easy access for the workers of the work, users in general of the Project and waste loading.

On the other hand, for the handling of dangerous and non-hazardous solid waste on board the dredge and auxiliary vessels, the following sections must be taken into account:

- The dredge and the auxiliary boats must separate the solid waste inside the boat, and then deliver it to the specialized port operator responsible for each

	ENVIRONMENTAL LICENSE MODIFICATION FOR THE CONSTRUCTION AND OPERATION PROJECT OF A PORT TERMINAL OF SOLID BULK CARGOES IN THE MUNICIPALITY OF TURBO	
	DESCRIPCIÓN DEL PROYECTO	Page 155 of 165
	GAT-391-15-CA-AM-PIO-01	Revision: B

type of waste generated. Additionally, said operators must deliver to the Contractor the documentary records and certificates that indicate the delivery period, the amount, the type of waste and treatment, as established in Annex V of the International Convention for the Prevention of Pollution by Ships - CONVENTION MARPOL 73/78.



- The dredge and auxiliary vessels will be subject to inspection by officials of the DIMAR, Ministry of Environment and Sustainable Development and the Environmental Audit, pursuant to compliance with Annex V of MARPOL 73/78.
- It is allowed to pour to the sea traces of food previously crumbled or crushed, when the motor ships are more than 12 nautical miles from the nearest land and these residues must be unloaded at a moderate rate and not instantaneously.
- The dredge and auxiliary vessels should contact a specialized port operator to perform the collection, treatment and final disposal of the hazardous solid waste generated within the motor ships.
- The port operator must have at its disposal and prepared all the necessary equipment for the attention of emergencies related to the service including possible fires and spills of products.

3.5 Project costs

The total direct costs of the project are:

ITEM	VALUE (USD)
a) Port Facilities	190.944.464
b) Roads to Nueva Colonia	5.047.994
c) Equipment	43.700.082

For a total direct project costs of **\$239.692.540 USD**.

	ENVIRONMENTAL LICENSE MODIFICATION FOR THE CONSTRUCTION AND OPERATION PROJECT OF A PORT TERMINAL OF SOLID BULK CARGOES IN THE MUNICIPALITY OF TURBO	 Page 156 of 165
	DESCRIPCIÓN DEL PROYECTO	
	GAT-391-15-CA-AM-PIO-01	Revision:

3.6 Project schedule

The construction schedule for Puerto Bahía Colombia de Urabá is 40 months and is discriminated as follows:

CODIGO	ACTIVIDAD	DURACIÓN mes																																																		
			1	2	3	4	5	6	7	8	9	10	11	12	13	14	15	16	17	18	19	20	21	22	23	24	25	26	27	28	29	30	31	32	33	34	35	36	37	38	39	40										
MUELLE, ZONA DE MANOBRAS Y PADO DE CONTENEDORES																																																				
1.0 ACTIVIDADES PRELIMINARES																																																				
1.1	Movilización y desmovilización																																																			
1.2	Rehabilitación vía de acceso al puerto																																																			
1.3	Mejoramiento de suelos obra provisionales																																																			
1.4	Construcción de campamento provisional obra																																																			
1.5	Acondicionamiento patio de almacenamiento de materiales de construcción																																																			
1.6	Acometida eléctrica e hidráulicas provisionales obra																																																			
1.7	Muelle provisional para recepción de materiales de construcción, incluye tableta, rellenos, acondicionamiento de terreno y obra necesarias para su buen funcionamiento (Emboscadero)																																																			
2.0 MUELLE (Ver Esquema N°1) Area: 25.095 M²																																																				
2.1	Suministro e instalación de Defensas Tipo MCN 1000 Grado 4																																																			
2.3	Suministro e instalación de Bitas																																																			
2.4	Rieles para grúa pórtico Tipo A-120																																																			
2.5	Cajas y Demás Elementos Embebidos en la Placa																																																			
2.6	Toperas y Placas de Apantamiento																																																			
2.7	Pilotes Hincados Metálicos D=70" E=11 mm(534 Verticales y 32 Inclinados)																																																			
2.8	Pilotes Hincados Metálicos D=60" E=11.9 mm(38 Verticales)																																																			
2.9	Concretos Prefabricados 35%																																																			
2.10	Concretos en Sitio 65%																																																			
2.12	Señalización Canal de Acceso y Diquesa																																																			
2.13	Balones de Enfollamiento																																																			
3.0 PLATAFORMA DE EMPALME (Ver Esquema N°1) Area: 3.861 M²																																																				
3.1	Pilotes Hincados Metálicos D=70" E=11 mm(48 Verticales y 6 Inclinados)																																																			
3.2	Concretos Prefabricados 35%																																																			
3.3	Concretos en Sitio 65%																																																			
4.0 PLATAFORMA DE ALONDENDORES (Ver Esquema N°1) Area: 32.095 M²																																																				
4.1	Pilotes Hincados Metálicos D=70" E=11 mm(397 Verticales y 68 Inclinados)																																																			
4.2	Pilotes Hincados Metálicos D=60" E=11.9 mm(70 Verticales)																																																			
4.3	Concretos Prefabricados 35%																																																			
4.4	Concretos en Sitio 65%																																																			
4.6	Estructuras Metálicas Para Reelers																																																			
(PASARELA EN MAR)																																																				
5.0 PASARELA EN MAR (VIADUCTO) 2.38 Km (Ver Esquema N°2) Area: 3.388 M.E. a 11.2=37.856 M²																																																				
5.1	Pilotes Hincados Metálicos D= 50" E=11.9 mm(10 Verticales y 420 Inclinados)																																																			
5.2	Concretos Prefabricados 35%																																																			
5.3	Concretos en Sitio 65%																																																			
5.5	Andén																																																			
5.6	Barridos																																																			

DESCRIPCIÓN DEL PROYECTO
 CAP 3 TDENG-CAT-REV-DAV-OK
 [[Medellin], 2015



ENVIRONMENTAL LICENSE MODIFICATION FOR THE CONSTRUCTION AND OPERATION PROJECT OF A PORT TERMINAL OF SOLID BULK CARGOES IN THE MUNICIPALITY OF TURBO



DESCRIPCIÓN DEL PROYECTO



Page 158 of 165

GAT-391-15-CA-AM-PIO-01

Revision:

CODIGO	ACTIVIDAD	DURACIÓN mes																																																
			1	2	3	4	5	6	7	8	9	10	11	12	13	14	15	16	17	18	19	20	21	22	23	24	25	26	27	28	29	30	31	32	33	34	35	36	37	38	39	40								
INSTALACIONES EN TIERRA DENTRO DE LA ZONA FRANCA																																																		
10.0	ZONA ADUANERA																																																	
10.1	Mejoramiento de Suelo																																																	
10.2	Portal de Entrada (No. 1)																																																	
10.3	Edificio Comedor de Administración (No. 4) - Son 3 Módulos típicos -																																																	
10.4	Bodega de Inspección de Exportaciones (No. 8)																																																	
10.5	Oficina de Policía Antinarcóticos (No. 9)																																																	
10.6	Módulo de Baños (No. 4) - Son 3 dobles -																																																	
10.7	Bodega de Inspección de Exportaciones de Alimentos Perecederos (Nos. 11 y 11A)																																																	
10.8	Bodega de Inspección de Importaciones (No. 12)																																																	
10.9	Bodega de Consolidación y Desconsolidación (No. 13)																																																	
10.10	Cobertizos de la Maestranza de Mantenimiento de Contenedores (No. 16)																																																	
10.11	Taller de Mantenimiento (No. 24)																																																	
10.12	Almacén de Repuestos (No. 25)																																																	
10.13	Estación de Bomberos (No. 28)																																																	
10.14	Entfermeo (No. 29)																																																	
10.15	Estación de Combustible (No. 30)																																																	
10.16	Tanques de Combustible y Oficina de Control (No. 31)																																																	
10.17	Biscuitas (No. 32)																																																	
10.18	Pavimento flexible (vehículo de diseño - Reach Stacker)																																																	
10.19	Ceramiento en Muro de Concreto (Altura : 3,00 mts.)																																																	
10.20	Ceramiento en Muro de Concreto (h : 3,00 mts) + Malla eslabonada (h : 3,00 mts)																																																	
INSTALACIONES DE REDES Y SERVICIOS																																																		
11.0	REDES DE ACUEDUCTO, ALCANTARILLADO SANITARIO Y PLUVIAL																																																	
11.1	Agua Potable Instalaciones en Tierra																																																	
11.2	Agua Potable Instalaciones en Muelle																																																	
11.3	Agua Residuales Instalaciones en Tierra																																																	
11.4	Agua Residuales Instalaciones en Muelle																																																	
11.5	Sistema Contra Incendio																																																	
11.6	Residuos Líquidos Oleaginosos																																																	
11.7	Agua Llavias Instalaciones en Tierra																																																	
11.8	Agua Llavias Instalaciones en Muelle																																																	

DESCRIPCIÓN DEL PROYECTO
CAP 3 TDENG-CAT-REV-DAV-OK
[[Medellin], 2015

	ENVIRONMENTAL LICENSE MODIFICATION FOR THE CONSTRUCTION AND OPERATION PROJECT OF A PORT TERMINAL OF SOLID BULK CARGOES IN THE MUNICIPALITY OF TURBO	
	DESCRIPCIÓN DEL PROYECTO	Page 160 of 165
	GAT-391-15-CA-AM-PIO-01	Revision:

3.7 Project organization

For the adequate development of the project activities, a suitable work team will be required, as it is presented in the project's organizational chart (see Figure Num. 3.63). This schedule may vary according to the dynamics of the project.

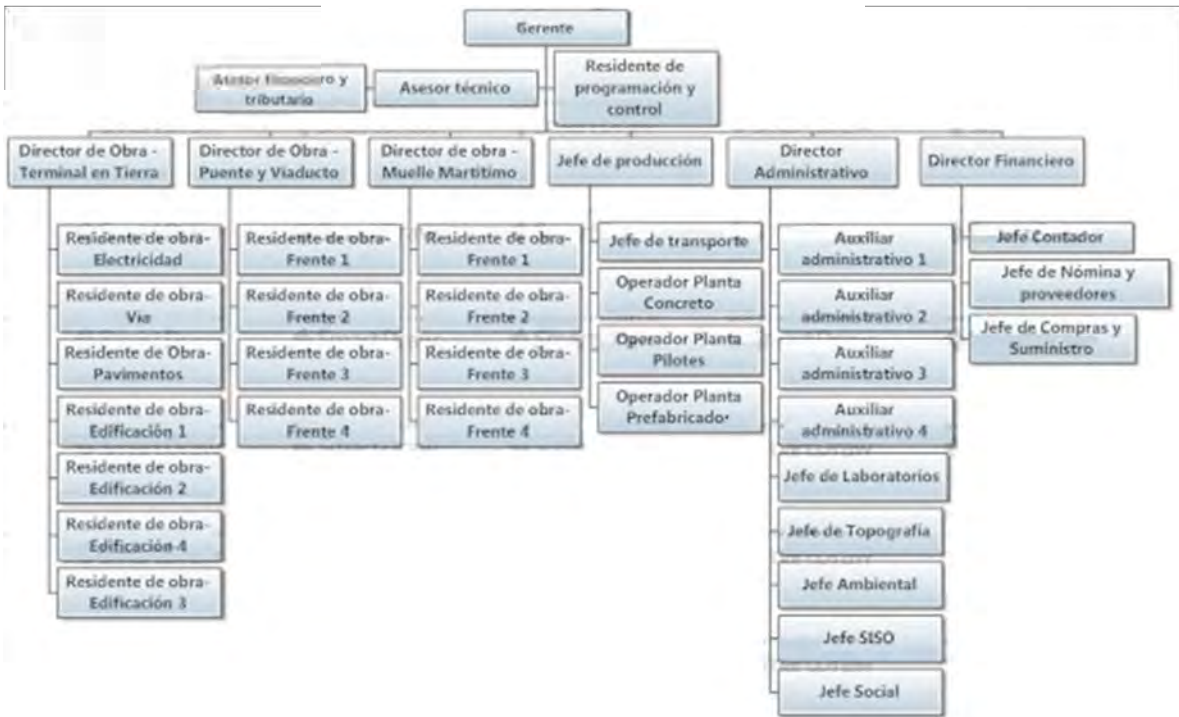





Figure Num. 3.63. Proposal for the Project Organization.
Source: Aqua & Terra Consultores Asociados

Figure Translation					
		Manager			
	financial and tax advisor	technical advisor	Programming and control resident		

	ENVIRONMENTAL LICENSE MODIFICATION FOR THE CONSTRUCTION AND OPERATION PROJECT OF A PORT TERMINAL OF SOLID BULK CARGOES IN THE MUNICIPALITY OF TURBO	
	DESCRIPCIÓN DEL PROYECTO	Page 161 of 165
	GAT-391-15-CA-AM-PIO-01	Revision:

Construction manager - ground terminal	Construction manager - Bridge and viaduct	Construction manager - Maritime dock	production manager	Administrative Director	Chief Financial Officer
Work Resident - Electricity	Work Resident - Front 1	Work Resident - Front 1	Transport chief	Administrative Assistant 1	Accounting chief
Work Resident - Road	Work Resident - Front 2	Work Resident - Front 2	Concrete plant operator	Administrative Assistant 2	Suppliers and payroll chief
Work Resident - Pavements	Work Resident - Front 3	Work Resident - Front 3	Pile driving plant operator	Administrative Assistant 3	Purchases and supplies chief
Work Resident - Building 1	Work Resident - Front 4	Work Resident - Front 4	Prefabricated plant operator	Administrative Assistant 4	
Work Resident - Building 2				Laboratory chief	
Work Resident - Building 3				Topography chief	
				Environmental chief	
				SISO chief	
				Social chief	

	ENVIRONMENTAL LICENSE MODIFICATION FOR THE CONSTRUCTION AND OPERATION PROJECT OF A PORT TERMINAL OF SOLID BULK CARGOES IN THE MUNICIPALITY OF TURBO	
	DESCRIPCIÓN DEL PROYECTO	Page 162 of 165
	GAT-391-15-CA-AM-PIO-01	Revision:

Some of the functions to be performed by each of the members are listed below.

- Construction Director:



The project manager is in charge of directing the development of the work in the technical, aesthetic, urban and environmental aspects of the project to be executed. Taking into account the terms of reference and the restrictions granted by the different licenses.

His functions are:



- Endorse and demonstrate that the project for which the construction license is requested complies with all applicable regulations and guidelines.
- Check that the project areas under his charge and for which he gave his approval are executed according to the plans and documents approved by the licenses and permits
- Keep a control and documentary record of the construction process by means of a work log.
- Supervises the works throughout the process and construction stages.
- At the end of the work to deliver to the owner of the same, all the technical documents of the work, such as the plans of finished work, if there was any modification to the original project, work logs and technical memories, and keep for your records a set of copies of them.
- Advise the owner of the work so that it does not fall into default due to omission or ignorance of the same.
- To process before the municipal administration, once the work is finished, the Work Completion Report, and if the type of construction is required by the Safety and Operation Approval..

- Administrative Director:

Obtain and maintain a human group with the necessary skills so that the project meets its objectives, designing and proposing guidelines, plans and programs to achieve an effective direction of Human management. Coordinate the proper application of these guidelines. Respond for the processes of: Personnel Linkage, Integral Training, Salary Compensation, Labor Welfare and Integral Health, in order to contribute to achieve the integral development of the personnel.

	ENVIRONMENTAL LICENSE MODIFICATION FOR THE CONSTRUCTION AND OPERATION PROJECT OF A PORT TERMINAL OF SOLID BULK CARGOES IN THE MUNICIPALITY OF TURBO	
	DESCRIPCIÓN DEL PROYECTO	Page 163 of 165
	GAT-391-15-CA-AM-PIO-01	Revision:



- Directing and coordinating the administrative progress of the unit under its charge, so that each of its officials work effectively and efficiently, complying fully with their duties and with the legal standards that are the responsibility of the public servant.
- Direct, coordinate and advance the process of selection and hiring of personnel
- Address and resolve the requests and problems of the servers from the labor and personal point of view for the best development in their functions.
- Know and apply the current regulations regarding the laws, agreements, decrees and conventions that govern social, legal, extralegal benefits and salaries that apply to employees, official workers and retirees.
- Strive for the best understanding and harmony in labor relations with employees, as well as for their social welfare and payment of all partial and total benefits.
- Coordinate the proper management of the types of contracts constituted at the personnel level, as well as the control of affiliations, withdrawals, news reports and other employer obligations contracted with the different external agencies for the welfare of the worker and the retiree.
- Comply with the current regulations (Laws, Decrees, Resolutions, Norms and Jurisprudence) regarding state contracting, analyzing, evaluating and recommending the technical, economic and legal favorability of the proposals presented; in addition to coordinating and monitoring compliance by the Contractor with all the obligations acquired before, during and after the conclusion of the contracts and that have been assigned by the Immediate Chief.
- Coordinate with occupational health everything related to the provision of uniforms and implements for personnel who require it, taking into account the necessary industrial safety measures.
- Permanently inform staff in charge of policies, rules, procedures, regulations of the administration and their dependencies.
- Inform the immediate boss about the eventualities that arise in the normal performance of his position.

	ENVIRONMENTAL LICENSE MODIFICATION FOR THE CONSTRUCTION AND OPERATION PROJECT OF A PORT TERMINAL OF SOLID BULK CARGOES IN THE MUNICIPALITY OF TURBO	
	DESCRIPCIÓN DEL PROYECTO	Page 164 of 165
	GAT-391-15-CA-AM-PIO-01	Revision:

- Draw up preliminary draft budget of its competence (payroll, social security, occupational health, training, quotas pension shares, pension liabilities and benefits, etc.) for the entire plant of administration charges.
- Submit periodic reports and those that are requested by the immediate boss, in a timely manner. Monitor the proper completion and handling of the resumes of active, inactive and retired personnel, and coordinate the management with the municipal file of inactive and retired personnel.
- Chief Financial Officer:
 - Coordination of the preparation of the Financial and Financial Statements, being in this respect especially important, the adjustments to the International Accounting Standards.
 - Supervision of Management Control: definition of procedures, design of budget processes.
 - Management of financial variables: Treasury management, Credit Management, Collection Management.
 - Optimization of the fiscal policy of the project.
 - Supervision of the relationship with third parties: External auditors, Administrations.
 - Studies of viability reports of investments / projects, strategic reorientations.
 - Selection, training and development of their teams.
- Production manager:

It is the maximum responsible for the correct functioning, coordination and organization of the production area of the project, both at the product level, as well as at the management level of the workforce, with the aim of fulfilling the expected production in time and quality of work, through the efficient administration of the department in charge.

- Manage and supervise the staff in charge
- Organize and plan the organization of the work
- Organize and plan the use of raw material and the distribution and transport of the product
- Coordinate the different fronts of the project, finance, human resources

	ENVIRONMENTAL LICENSE MODIFICATION FOR THE CONSTRUCTION AND OPERATION PROJECT OF A PORT TERMINAL OF SOLID BULK CARGOES IN THE MUNICIPALITY OF TURBO	
	DESCRIPCIÓN DEL PROYECTO	Page 165 of 165
	GAT-391-15-CA-AM-PIO-01	Revision:

- Optimize work processes within the production plant or work fronts
- Manager:
 - The coordination of project or organization resources
 - The execution of managerial or administrative functions to achieve coordination
 - Strategically plan the activities of the company, set the policies and objectives of the organization for the long and medium term, the strategic plan is based on a budget and projected financial statements.
 - It makes decisions and directs the direction of the company towards its objectives, for which it analyzes the situation and evaluates and weighs the actions to be taken and chooses the most convenient ones, these are generally in conditions of uncertainty.
 - Is the spokesperson and representative of the organization before the representatives of other entities, whether governmental, local or national authorities, press and media.